



component
developments



ABOUT CD

THE COMPANY

Component Developments was founded in 1983 to design and manufacture architectural stainless steel fabrications for the construction industry. Whilst the initial interest focused on drainage, the product portfolio gradually expanded as it became apparent that the unique properties of stainless steel were ideal for a whole range of products and applications.

LOCATION

The manufacturing facility is based in TELFORD, Shropshire.

FACILITIES

The Factory is equipped with the latest technological Computer Numeric Controlled machinery to ensure accurate and cost effective production.

QUALITY

Component Developments are a B.S.I. Registered Firm of Assessed Capability, having been awarded BS EN ISO 9002, formerly BS 5750 part 2.

TECHNICAL SUPPORT

An in-house Research & Development department constantly searches for product improvement. This, with continued investment in manufacturing procedures, ensures products that can be specified with confidence. Technical advice on product use and installation is freely available. Standard product details are offered to specifiers on Autocad and DXF discs.

BROCHURE

This brochure has been prepared to assist architects, engineers and contractors with the specification of stainless steel drainage and surface protection. The standard product range is detailed in the brochure with variations and special fabrications to individual customer requirements available on request.

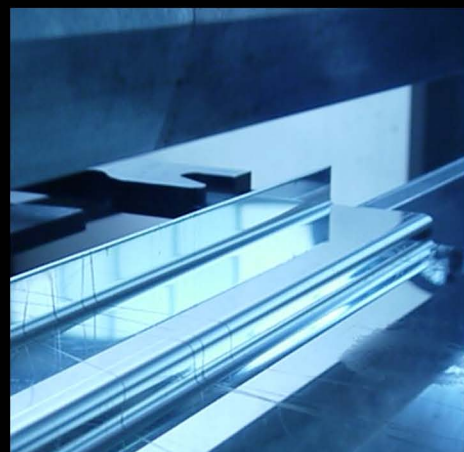
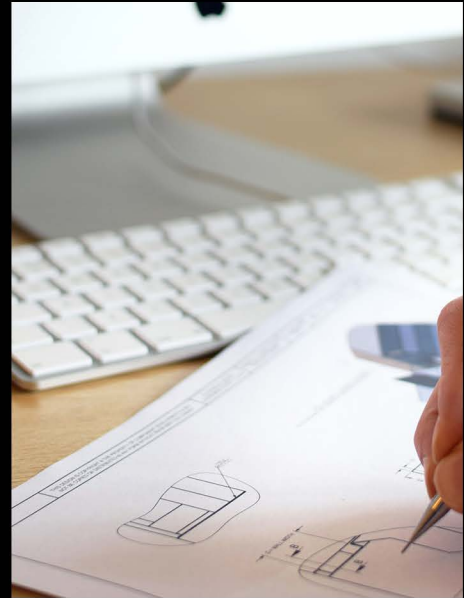

CONTENTS



component
developments

Drainage Channels 4

Gratings 8

Compact Channel 10

Gullies 12

Manhole Covers 16

Surface Protection 18

Specification 22

Bespoke Solutions 23

DRAINAGE CHANNELS

DESCRIPTION:

Component Developments' austenitic stainless steel floor drainage channels and gratings offer the specifier a strong, hygienic, functional and attractive solution to floor drainage design. The 3000 series drainage channels are designed to be used in conjunction with the 4000 series Gratings and 5000 series Gullies. (See appropriate sections in brochure).

Channels are designed with a built in fall and a range of edge profiles to accommodate all types of floor finishes. Anchor tangs and levelling bolts are provided to ease installations. Channels are manufactured from austenitic stainless steel grade 304 or 316 to BS 1449 part 2 1983 in 6000 mm maximum long lengths. Lengths are only limited by transportation logistics.

DESIGN:

The excellent smooth surface finish of stainless steel provides a self cleansing velocity for liquids at very shallow gradients. The self-cleansing velocity is 0.75 m/s. Velocities below this figure require manual flushing.

Widths of channels will depend on the splash area below discharging equipment or appliances and should be minimum 200mm wide overall for wash down installations. The discharge of the drainage channel is relative to the flow rate capacity of the outlet gully. (See 5000 series Gullies). Discharge capacities of both channel and gully will be reduced when conveying water-borne solids. Typical gradients are 1% (1:100) for liquid waste, 2% (1:50) for water-borne solids. The channel edge detail will depend on the floor finish, examples being tile, resin or vinyl. Channels can be designed to provide vinyl one side and resin or tile the other. For applications where heavy loads and / or thermal shock are anticipated, an expansion frame around the perimeter is recommended.

The expansion frame is supplied factory tack welded to all profiles, except the Vinoseal 3051, by specifying the channel profile and adding the suffix letters EF e.g. 3010EF. See profile on page 5, illustrating expansion frame. The expansion frame offers a true square strong edge for dressing-in resin. Also, the floor finish is separated from the channel, thus reducing the possibility of cracking under vibration or expansion.



CHANNEL PROFILES

All channels available with "V" base and built-in falls, shown by broken lines. Standard product range shown, special profiles to order.

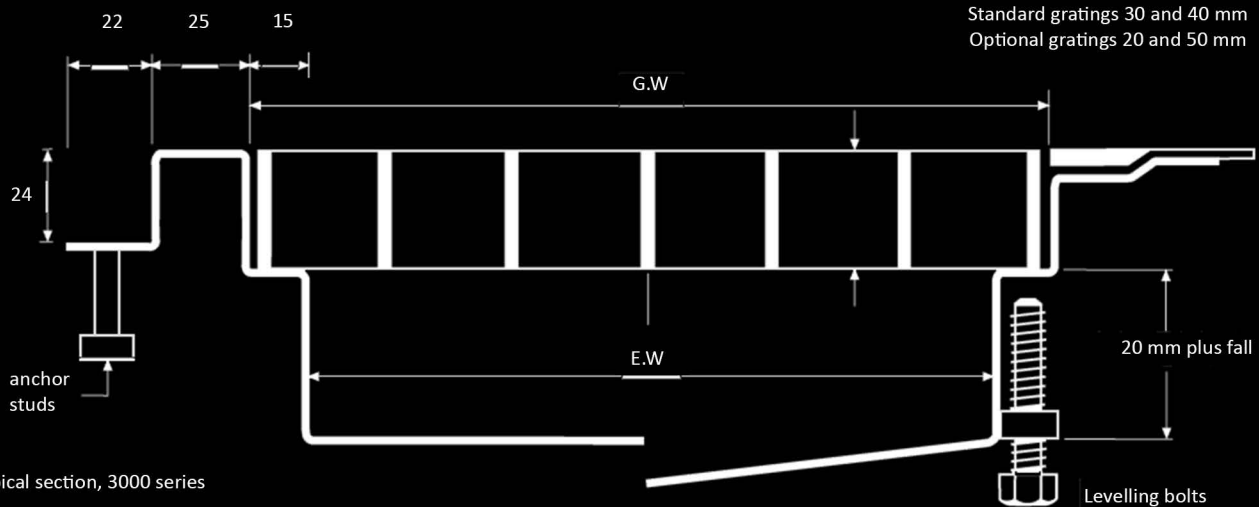
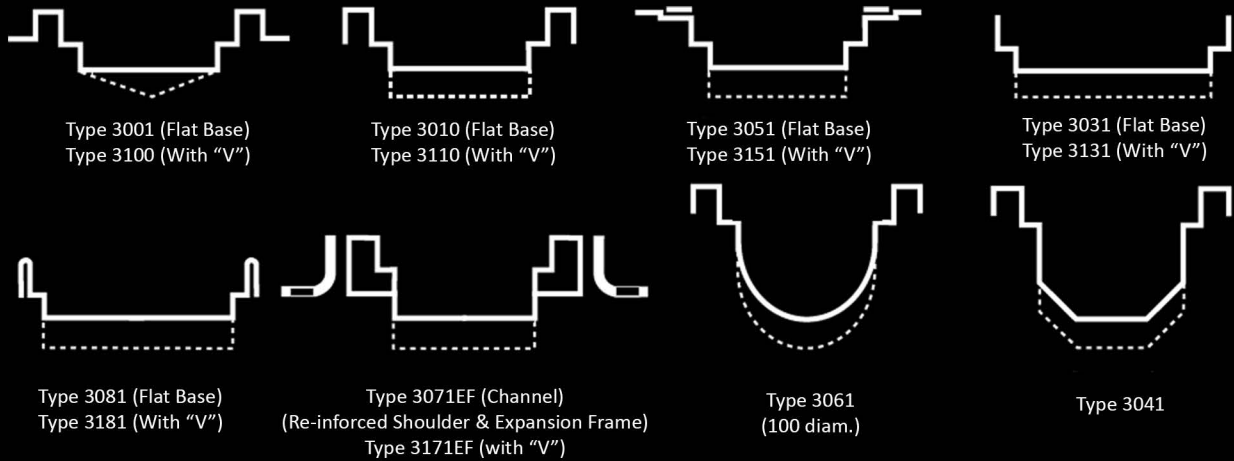

Typical section, 3000 series

GW = Grating Width, minimum 100mm wide, available in 50mm increments to maximum 600mm.

EW = Effective width.

3001 CHANNEL FLOWS

Depth at Head 50mm (20mm effective head depth) ks Value: 0.003mm

The two sets of flows and velocities shown are those at the head and the outlet positions respectively.

Channel Width	Gradient	3m Channel		6m channel	
		Flow (l/s)	Velocity (m/s)	Flow (l/s)	Velocity (m/s)
200mm (120 E.W.)	1/100	2.00 7.00	0.73 1.09	2.00 12.00	0.73 1.27
	1/200	1.00 3.00	0.49 0.64	1.00 4.00	0.49 0.74
250mm (170 E.W.)	1/100	3.00 10.00	0.76 1.20	3.00 20.00	0.76 1.44
	1/200	2.00 4.00	0.52 0.69	2.00 7.00	0.52 0.82
300mm (220 E.W.)	1/100	3.00 14.00	0.79 1.27	3.00 27.00	0.79 1.55
	1/200	2.00 6.00	0.53 0.73	2.00 10.00	0.53 0.87
450mm (370 E.W.)	1/100	6.00 26.00	0.82 1.39	6.00 52.00	0.82 1.75
	1/200	4.00 10.00	0.56 0.78	4.00 18.00	0.56 0.95
600mm (520 E.W.)	1/200	9.00 38.00	0.84 1.45	9.00 77.00	0.84 1.86
	1/100	6.00 15.00	0.57 0.81	6.00 26.00	0.57 0.99

DRAINAGE CHANNELS

Series 3000



component
developments

INSTALLATION

After careful unloading, identify the channel lengths and position them in correct sequence adjacent to the floor rebate into which they are to be installed.

- 1 Bolt sections together using the gaskets and bolts provided.
- 2 Tighten bolts from bottom centre working outwards, one left, one right, to equalise the pressure on the gasket.
- 3 Fit the 'O' ring seal to the channel outlet spigot.
- 4 Lift channel into floor rebate and connect to Gully. Using the levelling bolts provided, adjust channel height to finished floor level.
- 5 Bed levelling bolts with stiff-mix concrete and check top of channel has remained level.
- 6 Backfill void, ensuring concrete / grout is compacted into shoulders.
- 7 If vinyl floor, backfill flush with Vinoseal sub-frame.
- 8 Allow concrete to cure.
- 9 For deep channels, plug outlet and fill with water to ensure channels do not float, while concrete cures.
- 10 Twist or grind out the temporary brace-bars. Do not hammer out.
- 11 Remove debris from channel and clean with soapy water.
- 12 Flush channel.

Ensure the system is adequately protected from possible damage resulting from the continuation of building work in the area.

Channels with Expansion Frames

- 1 Place and level channel as previously described and bolt down expansion frame.
- 2 Backfill to floor level.
- 3 Apply floor finish.
- 4 Cut or grind out factory tack welds between expansion frame and channel to isolate each item.
- 5 Fill void with sealant recommended by flooring contractor.
- 6 Clean and protect as previously described.

Channels with Vinoseal clamping flange

- 1 Place, level, and backfill flush to Vinoseal sub-frame.
- 2 Remove clamping strips. Dress vinyl over sub-frame.
- 3 Replace clamping strips, screw down. Trim vinyl.
- 4 Clean and protect as previously described.

Channel-Gully: Typical Details

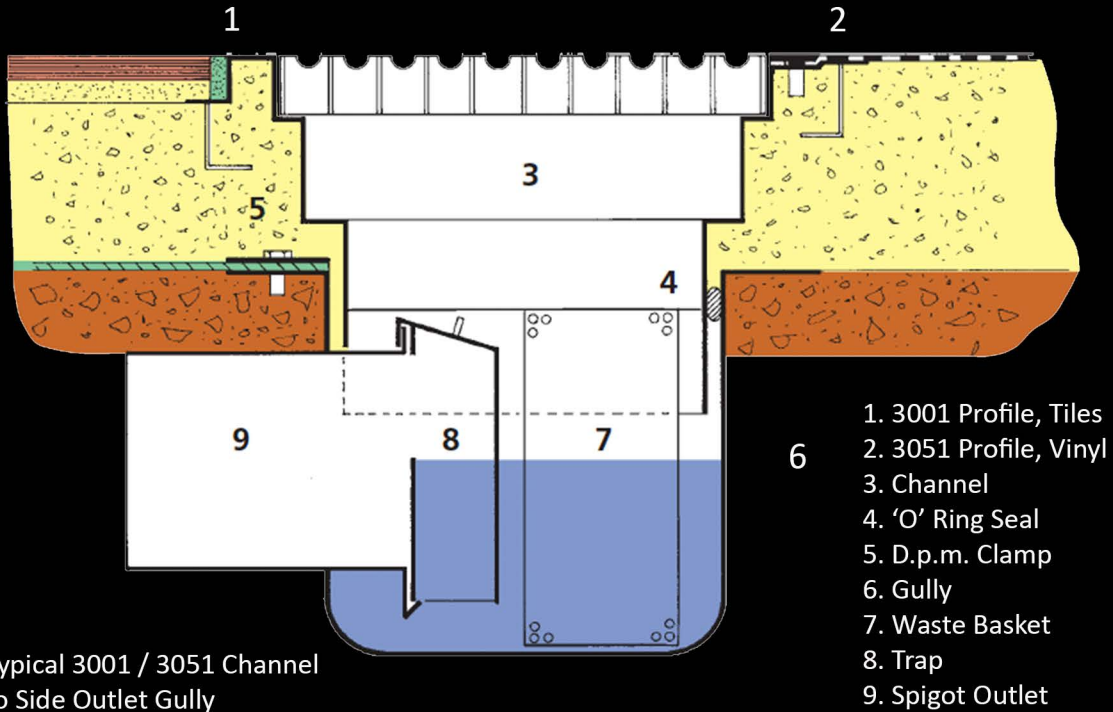

Typical 3001 / 3051 Channel to Side Outlet Gully

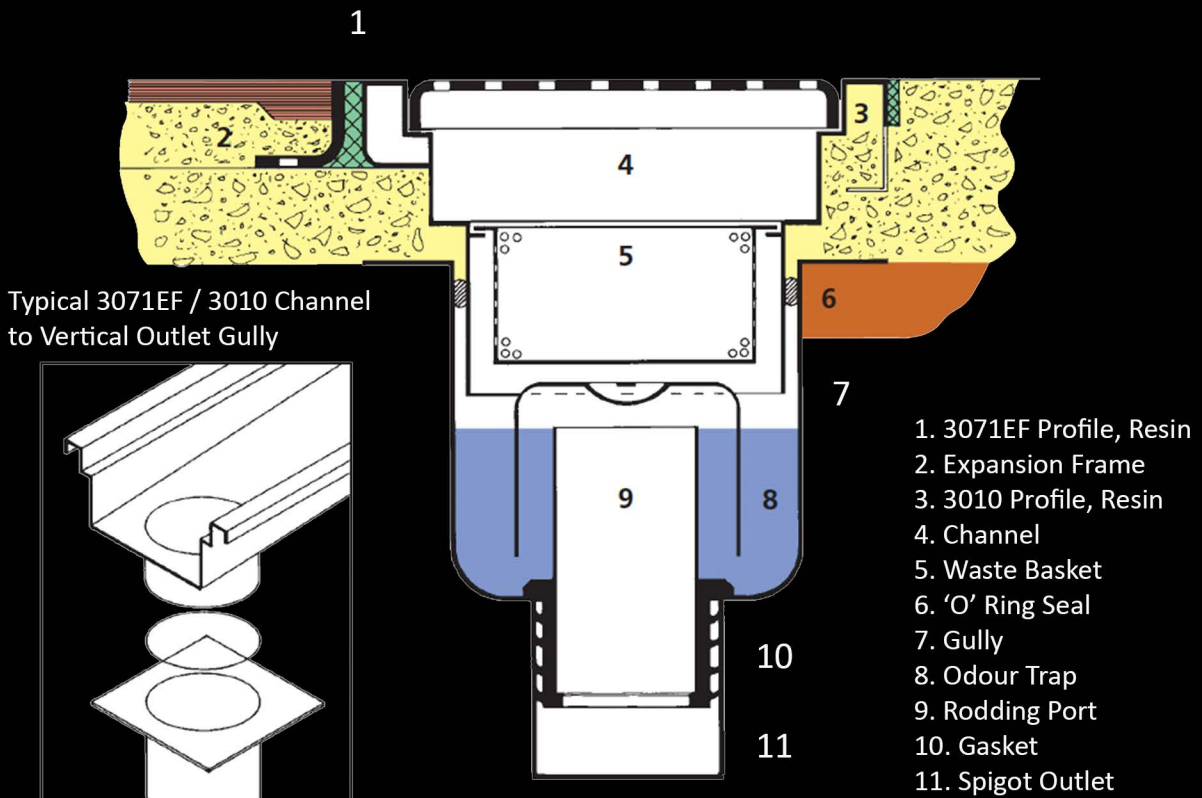

Typical 3071EF / 3010 Channel to Vertical Outlet Gully

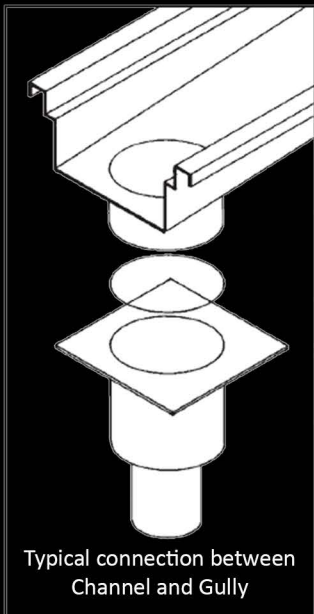

GRATINGS Series 4000

DESCRIPTION

The Component Developments' comprehensive range of stainless steel gratings are used in conjunction with the series 3000 Channels, series 5000 Gullies and 4001 Grating Frame Assemblies.

Square Mesh

Especially suitable for direct discharge from equipment. The free drainage area is up to 90% of the surface area achieving a virtually anti-splash installation. Loadings range from pedestrian to 5 tonne wheel load. Smooth mesh is suitable for fork lift trucks, anti-slip is used in kitchen and production areas. Gratings are electrolytically polished to give a smooth chrome-like finish which is both hygienic and easy to clean.

Available in grades 304 and 316.

Mesh size 23X10mm, 23X23mm.

TYPICAL APPLICATIONS

Refer to loading table

Commercial Kitchen,

Production Lines

Anti-slip 23X23mm Mesh, 30X2mm Load Bars

Pallet Truck Traffic

Anti-slip 23X10mm Mesh, 40X3mm Load Bars

Fork Lift Traffic

Smooth 23X23mm Mesh, 40X3mm Load Bars

Heelsafe Grating

Suitable for use in bare foot pedestrian situations for example showers and changing rooms. Also suitable in public areas for ladies high-heel shoes.

Perforated

For use in general production and bare foot pedestrian areas. Loadings from light to heavy duty, 2.5mm thick to 6mm thick reinforced. Smooth only, electrolytically polished or satin finish. Standard grating lengths are 600 mm to ease handling and cleaning, other lengths to order.

Locking Gratings

Gratings can be supplied with security screws to prevent unauthorised removal.

LOADINGS: STAINLESS STEEL GRATINGS							
free clearance	load cube	MESH23/23 WHEEL LOAD TONS					
in mm	mm/mm	500	1,000	2,000	3,000	4,000	5,000
150	100/100	20/3	25/3	40/3	50/3	60/3	60/3
	150/150	20/3	25/3	35/2	35/3	40/3	50/3
	200/200	20/3	25/2	30/2	30/3	30/3	40/3
200	100/100	30/2	40/2	50/3	60/3	60/3	60/3
	150/150	25/2	30/3	40/3	50/3	60/3	60/3
	200/200	25/2	30/2	30/3	40/3	40/3	50/3
250	100/100	30/3	40/3	60/3	60/3	60/3	60/3
	150/150	30/2	30/3	50/3	60/3	60/3	60/3
	200/200	30/2	30/3	40/3	50/3	60/3	60/3
300	100/100	35/3	50/3	60/3			
	150/150	30/3	35/3	50/3	60/3	60/3	60/3
	200/200	30/2	30/3	50/3	60/3	60/3	60/3
350	100/100	40/3	50/3	60/3			
	150/150	35/2	40/3	60/3			
	200/200	30/2	35/3	50/3	60/3		
400	100/100	40/3	50/3	60/3			
	150/150	30/3	50/3	60/3			
	200/200	30/3	40/3	60/3			
450	100/100	40/3	60/3				
	150/150	40/3	50/3	60/3			
	200/200	35/3	40/3	60/3			

BAR SIZE FOR GRATINGS 23 x 23 MESH

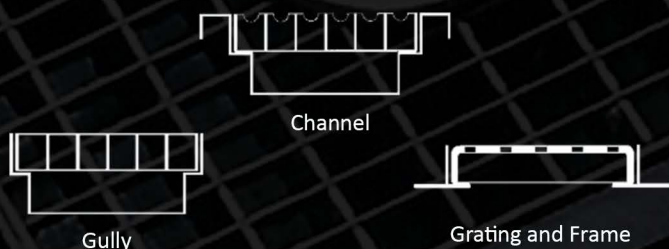

Grating Applications. For use with 3000 Series Channels, 5000 Series Gullies, or Frame Assembly.

GRATINGS Series 4000

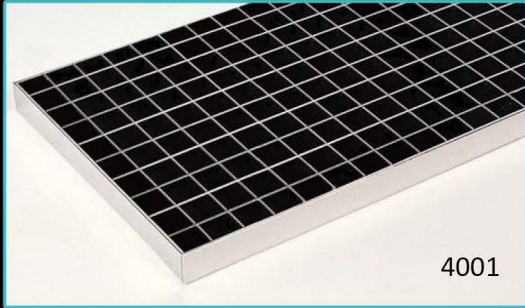

4001
Square Mesh
Smooth 23x23
(General Drainage in Fork Lift Areas)



4001
Square Mesh
Anti-Slip 23x23
(Discharge Drainage in Food Prep Areas)

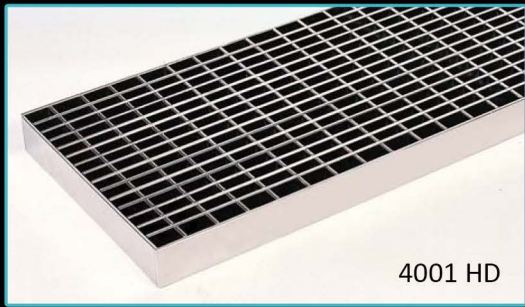

4001 HD
Square Mesh
Smooth H.D. 23x10
(Pallet Truck Traffic)



4501
Heel Safe
(Bare Foot Traffic)

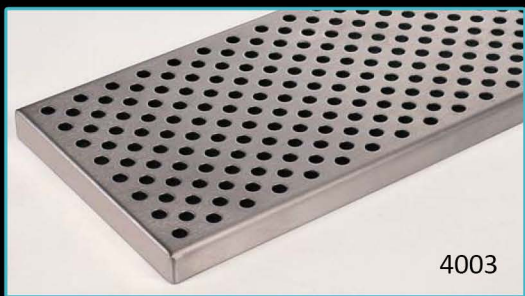

4003
Perforated Circles
10 diam. Circles
(Ventilation Grilles)



4003
Perforated
20x10 Ovals
(Food and Pharmaceutical Areas)

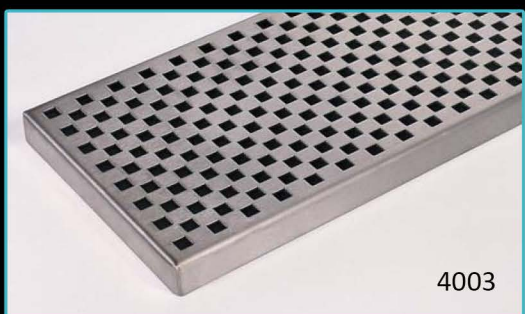

4003
Perforated
10x10 Squares
(Bare Foot Traffic)



4003
Perforated
40x6 Ovals
(Bare Foot Traffic)

SUPER COMPACT DRAINAGE CHANNEL Series 3600



DESCRIPTION

The Component Developments' range of Super Compact drainage channels provide a cost-effective easy to clean system which ensures a free flow of liquid waste. The channels do not require gratings and are available with or without a built-in-fall. Especially suitable for the conveyance of surface water in wet production areas, swimming-pool surrounds and changing rooms.

DESIGN

The minimum flow rate capacity is equivalent to a 54mm diameter pipe. Jumbo Compact is equivalent to a 100mm diameter pipe. As access is restricted compared to the series 3000 drainage channels, the Super Compact channel should be used for the conveyance of liquids, not water-borne solids.

The discharge capacity of the channel is relative to the flow rate of the outlet Gully. (See 5000 Gullies). Typical gradients are from 1% (1:100) to 0.5% (1:200). However, the channel has been successfully installed level, only the ends being slightly shimmed higher to prevent back-flow and ponding. The edge profile is relevant to the floor finish, for example tile, resin or vinyl.

INSTALLATION

After careful unloading, identify the channel lengths and position in correct sequence adjacent the floor rebate into which they are to be installed.

Bolt sections together using the gaskets and bolts provided. Tighten bolts from bottom centre working outwards, one left, one right, to equalise the pressure on the gasket. Fit the 'O' ring seal to the channel outlet spigot. Lift channel into floor rebate and connect to gully. Using the levelling bolts provided, adjust channel height to finished floor level. Bed levelling bolts with stiff-mix concrete and check top of channel has remained level. Backfill void, ensuring concrete / grout is compacted into shoulders. If vinyl floor, backfill flush with Vinoseal sub-frame. Allow concrete to cure. For deep channels, plug outlet and fill with water to ensure channels do not float, until the concrete has cured. Remove debris from channel and clean with soapy water. Flush channel. Ensure the system is adequately protected from possible damage resulting from the continuation of building work in the area.

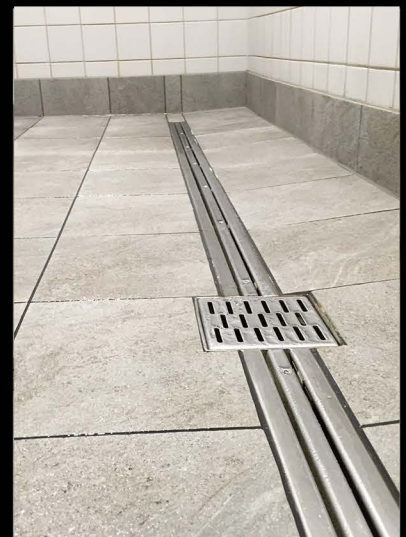

TYPICAL PROFILES

Channels available with composite edge details, i.e. 3610 one side, 3610V other.

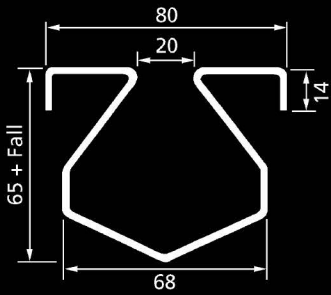

Type 3610 with built in fall
Type 3611 50mm constant depth

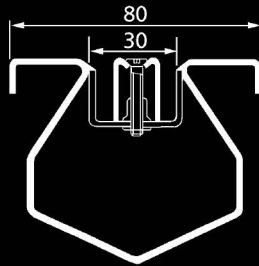

Type 3610G with built in fall
Type 3611G 50mm constant depth

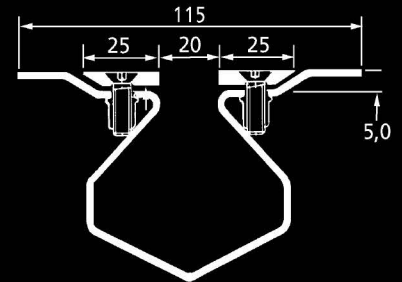

Type 3610V with built in fall
Type 3611V 50mm constant depth

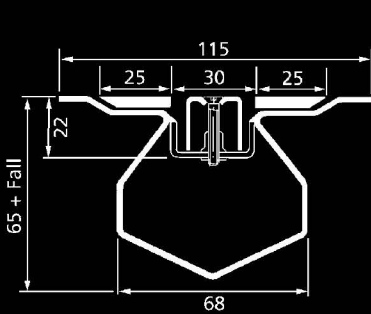

Type 3610VG with built in fall
Type 3611VG 50mm constant depth

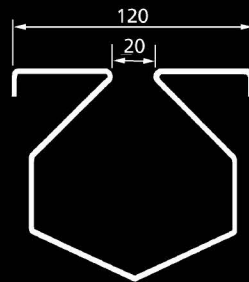

Type 3620 with built in fall
(Jumbo Compact)

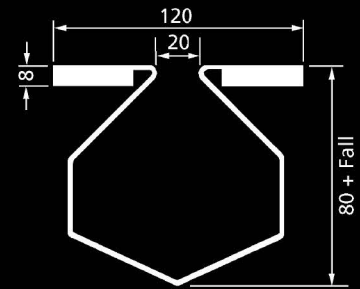

Type 3630 with built in fall
(Reinforced Jumbo Compact)

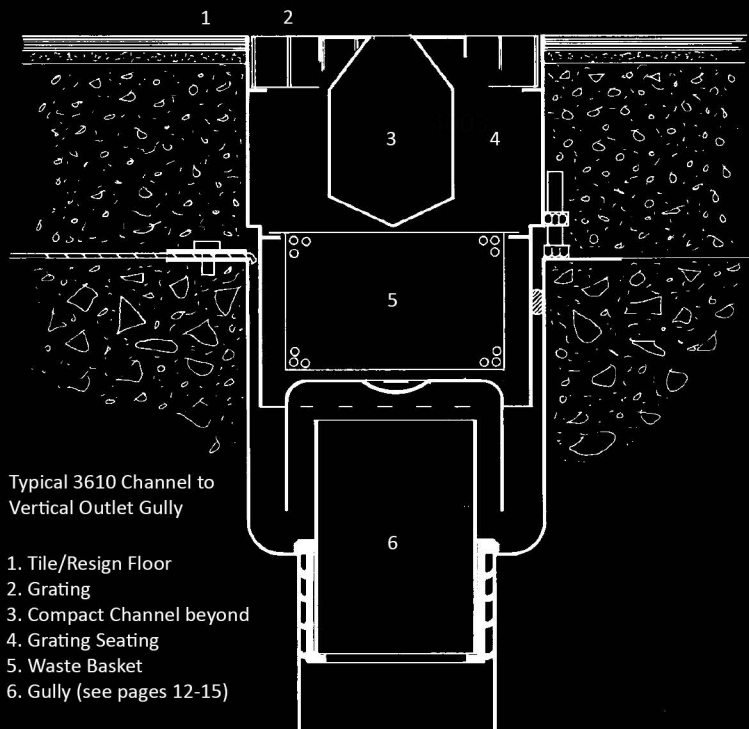

Typical 3610 Channel to
Vertical Outlet Gully

1. Tile/Resign Floor
2. Grating
3. Compact Channel beyond
4. Grating Seating
5. Waste Basket
6. Gully (see pages 12-15)

Typical Outlet Details

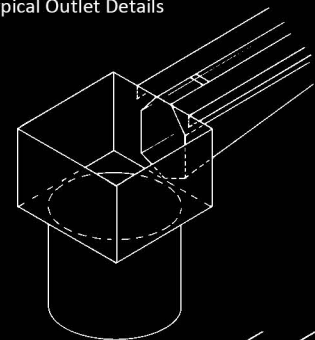

Type 3600
Compact Channel
with fall to Gully
(see opposite)

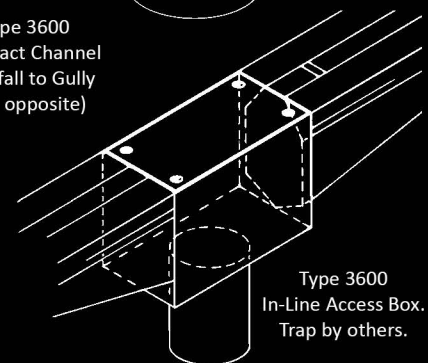

Type 3600
In-Line Access Box.
Trap by others.

GULLIES Series 5000

Channels available with composite edge details, i.e. 3610 one side, 3610V other.

DESCRIPTION

The Component Developments' 5000 series of Gullies are designed to be used as individual drainage points, or can be used in conjunction with the 3000 Channel and 3600 Compact Channel systems.

The range has 6 sizes of Gully, 5150, 5200, 5300, 5409, 5412 and 5415. Numerous variations can be achieved by using interchangeable Grating Seatings.

Gullies are height adjustable for ease of installation and incorporate removable gratings, odour traps, rodding ports and waste baskets, allowing full bore access.

Outlets are vertical or horizontal. Additional standard fittings to compliment site and clients requirements include D.P.M. clamping flanges, back inlet pipes, tun dishes, and sealed cover plates.

DESIGN

The design depends on the function of the Gully, for example floor washdown, direct discharge from equipment, rodding point, or associated use with the 3000 series drainage Channels.

Gratings should be selected for their wash down requirements, (free drainage area) and loading capacities. (See 4000 series Gratings)

Flow rates are shown in the table below.

However, basket size can become the overriding factor when selecting a Gully, or, head of water when considering deluge drainage.

The edge profile will depend on the floor finish, for example tile, resin or vinyl.

Outlet diameters are compatible to uPVC pipes sizes to BS 4660, IE, 82, 110, 160.

Standard couplings and adaptors are readily available within the industry to connect to clay and cast iron drainage. See page 14.

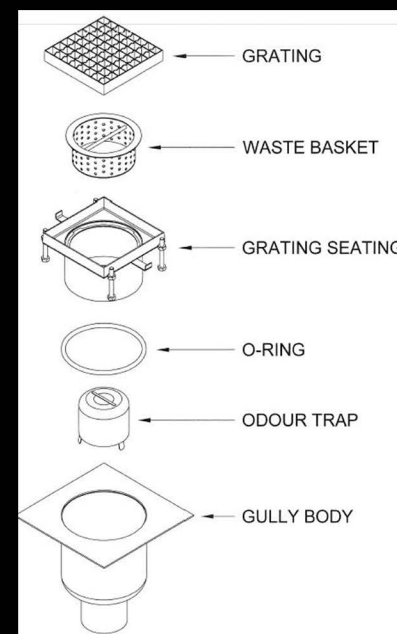

GULLIES Series 5000

Channels available with composite edge details, i.e. 3610 one side, 3610V other.



DESCRIPTION

The Component Developments' 5000 series of Gullies are designed to be used as individual drainage points, or can be used in conjunction with the 3000 Channel and 3600 Compact Channel systems.

The range has 6 sizes of Gully, 5150, 5200, 5300, 5409, 5412 and 5415. Numerous variations can be achieved by using interchangeable Grating Seatings.

Gullies are height adjustable for ease of installation and incorporate removable gratings, odour traps, rodding ports and waste baskets, allowing full bore access.

Outlets are vertical or horizontal. Additional standard fittings to compliment site and clients requirements include D.P.M. clamping flanges, back inlet pipes, tun dishes, and sealed cover plates.

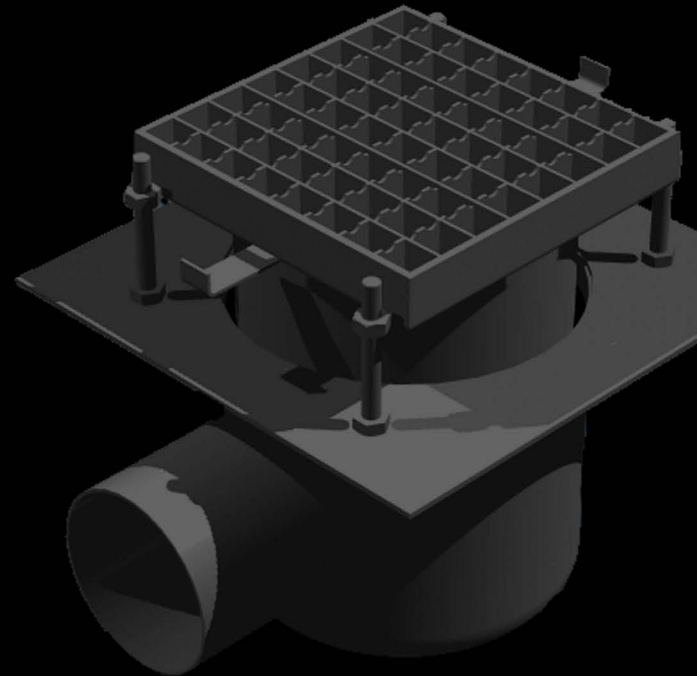

DESIGN

The design depends on the function of the Gully, for example floor washdown, direct discharge from equipment, rodding point, or associated use with the 3000 series drainage Channels.

Gratings should be selected for their wash down requirements, (free drainage area) and loading capacities. (See 4000 series Gratings)

Flow rates are shown in the table to the right.

However, basket size can become the overriding factor when selecting a Gully, or, head of water when considering deluge drainage.

The edge profile will depend on the floor finish, for example tile, resin or vinyl.

Outlet diameters are compatible to uPVC pipes sizes to BS 4660, IE, 82, 110, 160.

GULLY TYPE No.	CAPACITY L/SEC	A	B	C	D	E	F
5150	1.8	250	164	165	85	146	70
5200	3.0	300	204	195	110	186	95
5300	6.0	400	284	255	110	266	150
5409	9.0	400	300	255	160	282	140
5412	12.0	550	450	255	160	432	140
5415	15.0	600	500	315	200	482	165

GULLY TYPE No.	SIDE OUTLET 'G'	VERTICAL OUTLET 'G'	'H'
5150	15-28	20-80	150
5200	20-35	20-80	200
5300	20-85	20-80	300
5409	20-55	20-80	300
5412	20-55	20-80	450
5415	20-55	20-80	500

Standard couplings and adaptors are readily available within the industry to connect to clay and cast iron drainage. See page 14.

HEIGHT ADJUSTABLE GULLIES



component
developments



Gully 5150 Vertical Outlet
Flow Rate 1.8 l/s Outlet diam. 85, 110mm



Gully 5150 Side Outlet
Flow Rate 1.8 l/s Outlet diam. 85, 110mm



Gully 5200 Vertical Outlet
Flow Rate 3.0 l/s Outlet diam. 110mm



Gully 5200 Side Outlet
Flow Rate 3.0 l/s Outlet diam. 110mm



Gully 5300 Vertical Outlet
Flow Rate 6.0 l/s Outlet diam. 110mm



Gully 5409 Side Outlet
Flow Rate 9.0 l/s Outlet diam. 160mm



Gully 5412 Vertical Outlet
Flow Rate 12.0 l/s Outlet diam. 160mm



Gully 5415 Side Outlet
Flow Rate 15.0 l/s Outlet diam. 200mm

GULLIES Series 5000



component
developments

INSTALLATION

Ensure that the drain pipe to be connected to the Gully is
1 the correct depth below floor level.

Gullies push fit to PVC, 110mm, 160mm diameter sockets,
2 use the appropriate adaptor for clay or cast iron pipework.

Check Gully is both level and plumb.
3

If a D.P.M. is being used, press onto Gully and secure with
4 the D.P.M. clamping flange.

Place the 'O' ring seal over the spigot of the Grating seating.
5 (Omit if D.P.M. flange is used).

Insert spigot into the Gully, ensuring 'O' ring has sealed.
6

Using the levelling bolts, adjust to finished floor level and
7 bed in position.

Check level, height and position prior to back filling.
8

Ensure the following are fitted prior to cleaning with soapy
9 water, - Grating, Basket, Odour Trap, Rodding Port and Gasket.

Ensure the gully is adequately protected from possible
10 damage resulting from the continuation of building work in the area.

For height adjustable side outlet gullies, the spigot to the
11 grating seating may require site cutting to allow the spigot to seat over the trap.

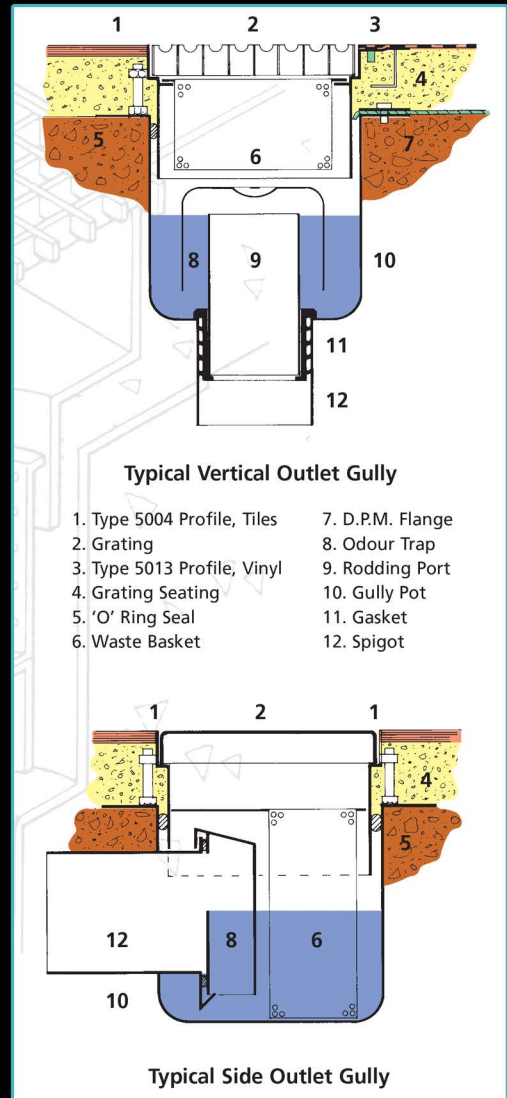

ADAPTORS FROM OUTLETS

85	To 100	Cast Iron,	Glynwed	GT 01
110	To 100	Vitrified Clay,	Hepworth	AD 400
160	To 150	Vitrified Clay,	Hepworth	AD 600
110	To 100	Cast Iron,	Glynwed	TD 02, GT 01
160	To 150	Cast Iron,	Glynwed	TD 02, GT 01

Gully	Typical Application	Max Inlet dia.
5150	Light Duty. Wash Down + Channel Drainage	32
5200	Medium Duty. Wash Down + Channel Drainage	38
5300	Heavy Duty. Wash Down + Channel Drainage	54
5400	Very Heavy Duty. Wash Down + Channel Drainage	82

TYPICAL PROFILES

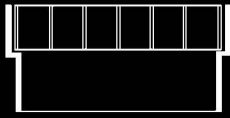

Type 5004
Grating Seating



Type 5004
Grating Seating
(Sealed Cover Plate)

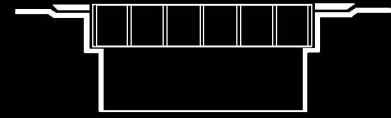

Type 5013
Grating Seating
(Vino seal)

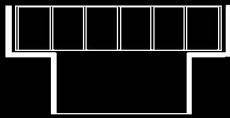

Type 5004
110 diam. Spigot

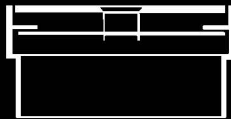

Type 5110
Quick Release Cover



Type 5010

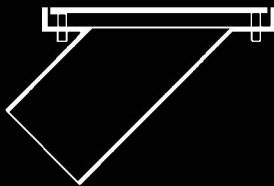

Type 5600
Rodding Eye
45° x 110 Spigot

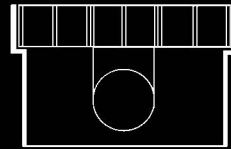

Type 5004
with Back Inlet



Type 5004
Grating Seating
with Tun Dish



Grating



Waste
Basket

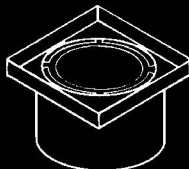

Grating
Seating



O Ring

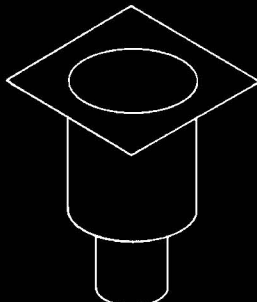

Gully Body
(Trap within)

Breakdown of Series
5004 Grating Seating and
Series 5000 Vertical
Outlet Gully

Type 5013 with Tun Dish, to 5200 Gully



MANHOLE COVERS AND FRAME

Series 4200

DESCRIPTION

The Component Developments' series 4200 of Covers has been designed for internal use where hygiene and durability are of prime importance. The covers are recessed to accept a screed with a tile or resin floor finish.

Installed, they give an aesthetic appearance leaving only the polished perimeter edge bar visible. Lockable and double sealed, the covers are gas tight.

Covers are removed for access by replacing the holding down bolts with the threaded lifting handles supplied.

The 4200 covers are supplied as individual or multiple units.

Multiple Covers can be used in conjunction with a stainless steel channel to form a continuous duct.

Loading capacities are pedestrian. Available in grade 304 or 316. Specially designed heavy duty covers are available on request.

Standard clear opening sizes shown below.

450mm x 450mm	750mm x 750mm
600mm x 450mm	900mm x 600mm
600mm x 600mm	900mm x 750mm
750mm x 600mm	900mm x 900mm

Specials made to order.

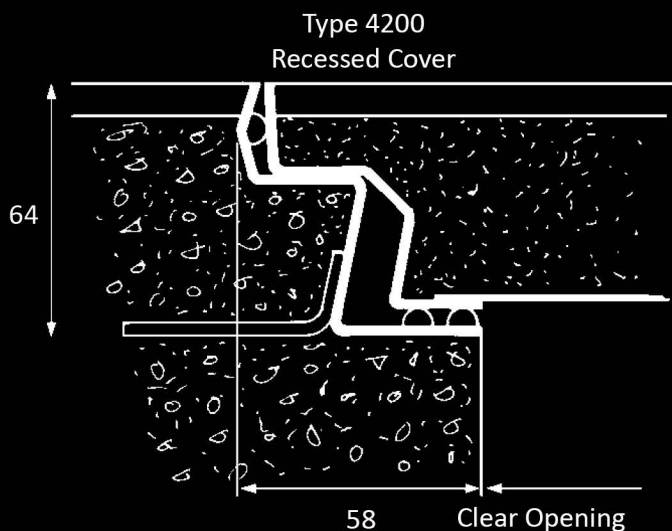

MANHOLE COVERS AND FRAME

Series 4300



component
developments

DESCRIPTION

The Component Developments' Series 4300 of Covers were introduced in 1984 to provide a lightweight double sealed Cover and Frame for use with vinyl flooring.

The two part cover includes the Vinoseal clamping strip which secures the vinyl permanently in position to prevent lifting.

The frame includes an inner clamping strip to secure the vinyl from the surrounding floor.

Installed, only the polished stainless steel trim is visible.

Covers are removed for access by replacing the holding down bolts with the threaded lifting handles supplied.

The 4300 covers are supplied as individual or multiple units.

Multiple Covers can be used in conjunction with a stainless steel channel to form a continuous duct. Loading capacities are pedestrian. Available in grade 304 or 316.

Standard clear opening sizes shown below.

450mm x 450mm	750mm x 750mm
600mm x 450mm	900mm x 600mm
600mm x 600mm	900mm x 750mm
750mm x 600mm	900mm x 900mm

Specials made to order.

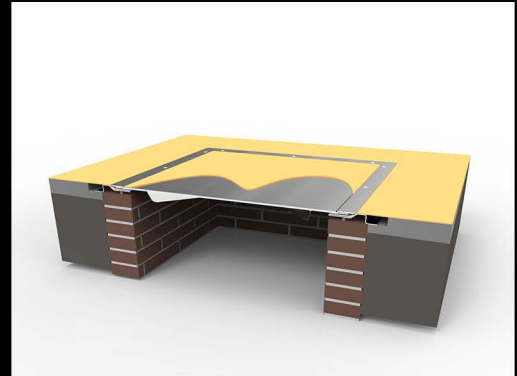

Type 4300
Vinoseal Cover

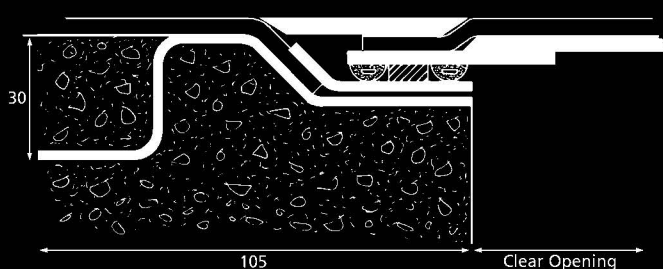

SURFACE PROTECTION



DESCRIPTION

Component Developments' range of Corner Guards and Buffer Rails in austenitic stainless steel provide surface protection wherever corners and edges are vulnerable to impact damage.

Profiles are designed to suite a wide range of wall finishes including tiles, fair-face blockwork and p.v.c. sheeting.

Secret post fixings are available.

Manufactured under BS5750 Part 2 Quality Assurance System, the product range has been utilised extensively in hospitals, schools, commercial kitchens, food processing plants, supermarkets, breweries, shopping arcades and leisure centres



CORNER GUARDS

Series 1000



Type No. 1001/40

Standard Corner Guard

Standard Dimensions: 40 x 40 x 1.5mm

The 3-cornered profile provides maximum stability and rigidity whilst the radiused edges ensure a smooth, flush finish to tiled and other surfaces.

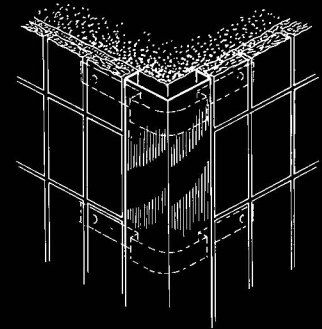
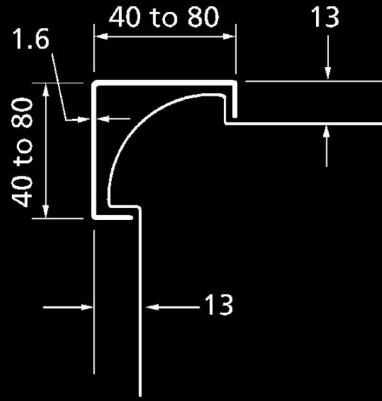

Type No. 1001/25

Low Profile Corner Guard

Standard Dimensions: 25 x 25 x 1.5mm

As 1001/40, but smaller flange widths provide more discreet protection.

Immediate ex-stock delivery

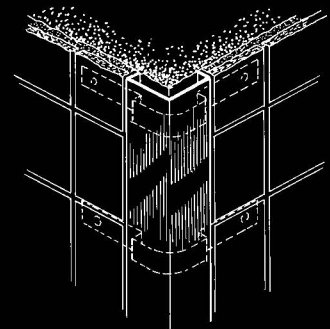
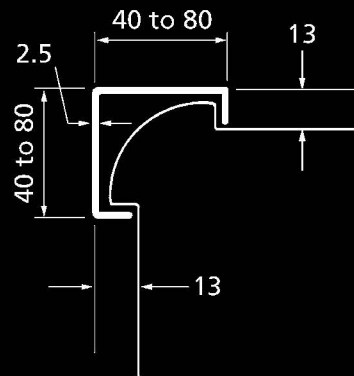

Type No. 1003

Heavy Duty Corner Guard

Standard Dimensions: 40 x 40 x 2.5mm

This section is particularly suited to areas where vehicles, trailers and other traffic present exceptional damage hazards, when backfilled it represents the ultimate solution to edge protection.

Immediate ex-stock delivery

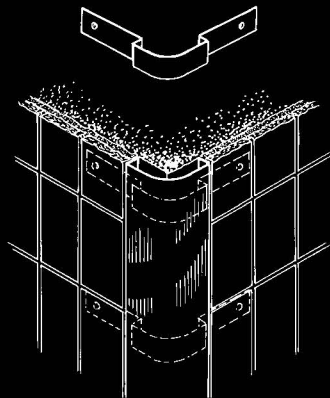
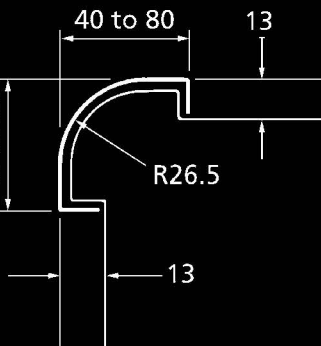

Type No. 1004

Quadrant Corner Guard

Standard Dimensions: 40 x 40 x 1.5mm

A popular section in areas where the volumes of pedestrian traffic are high — such as hospitals and clinics.

Immediate ex-stock delivery

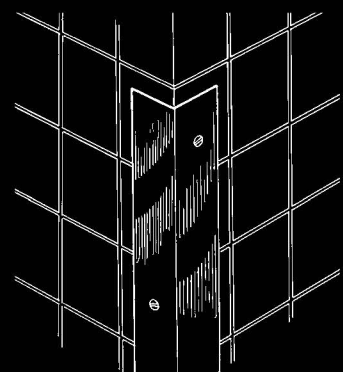
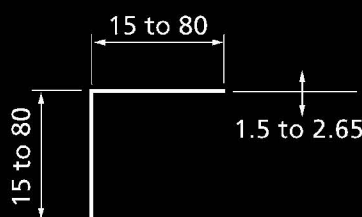

Type No. 1002

Perm-a-fix Corner Guard

Standard Dimensions: 40 x 40 x 1.5mm

Also available drilled and countersunk for fixing to surfaces which are unsuitable for bonding.

Designed for bonding to areas which are otherwise unprotected and which might already be damaged, its low cost, speed and ease of fixing make it the ideal choice, avoiding the necessity for expensive renovation work.

BUFFER RAILS

Series 2000

Type No. 2070

Dimensions: 25 x 100 x 2mm

30 x 150 x 2mm

30 x 200 x 2mm

For surface protection to walls to resist impact damage. 2 No. brackets per metre.

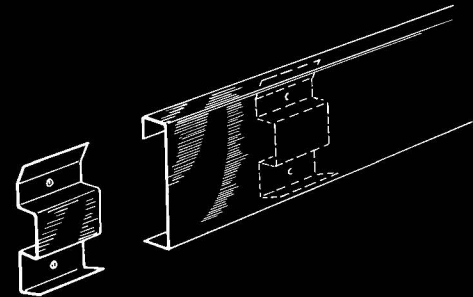
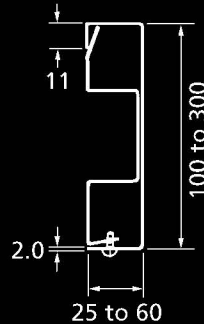

Type No. 2071

Dimensions: 25 x 100 x 2mm

30 x 150 x 2mm

30 x 200 x 2mm

For surface protection to walls to resist impact damage. Continuous bracket for extra rigidity and possible use as conduit.

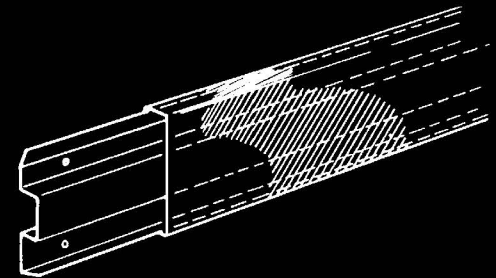
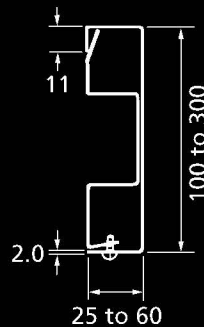

CAPPINGS

Type No. 2058

Dimensions: 40 x 140 x 40mm

Or to suit wall construction. Surface protection for dwarf walls. Peak profile deters shelf-type use.

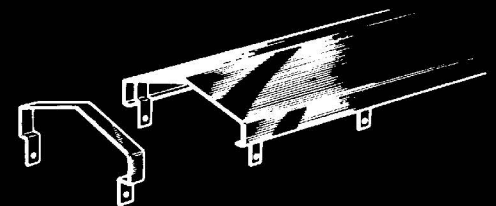
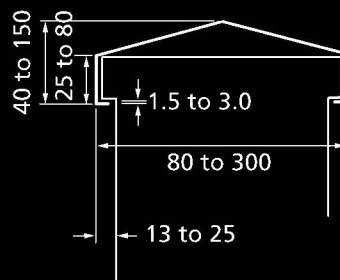

Type No. 2050

Dimensions: 40 x 140 x 40mm

Or to suit wall construction. Surface protection for dwarf walls, in Horizontal and Vertical planes.

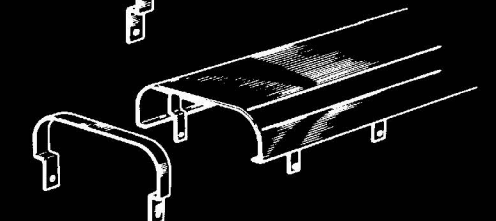
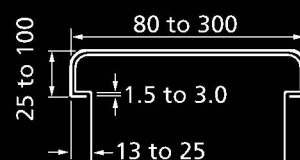
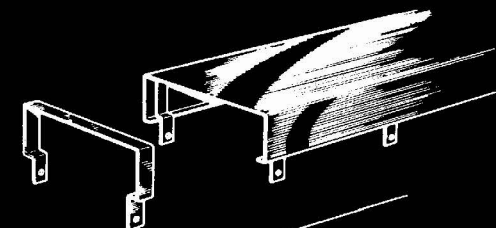

PREPARING A SPECIFICATION

STAINLESS STEEL —THE MATERIAL

There are three important classes of stainless steel namely: martensitic, ferritic and austenitic. The first two types of steel are usually plain chromium steels, commonly having not less than 11% chromium. The martensitic types can be hardened by heat treatment as is the case with plain carbon steels, but ferritic steels, which in general have lower carbon and higher chromium contents than martensitic steels do not respond in this manner. Both martensitic and ferritic steels are magnetic. The third category of stainless steel is the austenitic range and these steels contain nickel as well as chromium and are often called 18/8, i.e. 18% chromium and 8% nickel.

There are many variations to this composition but it serves well as a base to work from. Austenitic steels, unlike ferritic and martensitic, are non-magnetic and it is not possible to harden them by heat treatment. The only method of hardening these steels is through cold forming or deformation when strain hardening takes place rapidly. The steels can be restored to a fully softened condition by annealing, sometimes referred to as solution treatment.

Molybdenum can be added to the 18/8 type of steel to give even more enhanced corrosion resistance, and thus type 316 steels containing between 2.0% and 3.0% of molybdenum are principally used in the chemical and petrochemical industries where resistance to, for example, corrosion media containing chlorides is required. The point should be made, however, that even these steels are not immune to all kinds of chemical attack from such reducing solutions as hydrochloric or oxalic acid, particularly when these acids are hot and/or highly concentrated.

SPECIFYING PRODUCTS

Careful consideration to the following factors will assist to determine a product specification.

CHANNELS:	Profile	Floor finish see page 5
	Width	Function - washdown or deluge capacity
	Fall	1% washdown. 2% deluge
	Outlet	To 5000 gully. To 110/160 drain pipe
	Grade	304 or 316
GRATINGS:	Square Mesh	Maximum drainage area
	Loadings	See page 8
	Pressed	Pattern, thickness Grade. 304 or 316

TYPICAL SPECIFICATIONS

The following are typical specifications for various applications. Please consider functional and aesthetic criteria relevant to floor finish, loadings, discharge and structural requirements.

KITCHEN	<i>Channel profile 3001.</i> 300 wide with 250 wide Antislip square mesh gratings, 23 x 23, 30 x 2. Head depths 50 with built-in fall to Type 5200 height adjustable gully with basket, trap, and 110 o.d vertical outlet. All grade 304.
	<i>Washdown Gully Type 5300.</i> height adjustable with Antislip gratings, 23 x 23, 30 x 2. Basket, trap and 110 vertical outlet. Grade 304.
	<i>Manhole Cover + Frame Type 4200.</i> Double sealed screw down recessed cover, clear opening, 600 x 600, complete with lifting handles. Pedestrian loading. Grade 304.
	<i>Corner Guards Type 1001/40.</i> 40 x 40 x 1.5 polished and coated complete with fixing brackets. Grade 304.
	<i>Buffer Rail Type 2051.</i> 150 x 30 polished and coated complete with fixing brackets. Grade 304.
FOOD PROCESS	<i>Channel Profile 3041EF.</i> 200 wide with 150 wide smooth square mesh gratings 23 x 10, 30 x 3. Expansion frame to channel perimeter 40 x 40 x 4. Head depth 80 with built-in fall to Type 5200 height adjustable gully with basket, trap, 110 vertical outlet and D.P.M clamping flange. All grade 304.
	<i>Washdown Gully Type 5200</i> height adjustable with 6mm thick perforated plate, 20 x 10 ovals. Basket, trap and 110 side outlet. Grade 304.
LEISURE:	Supercompact Channel Profile 3610VG with Vinoseal clamping flange, lockable central bar and built-in fall to Type 5150 height adjustable gully with 2mm thick perforated plate, 40 x 6 slots, basket, trap and 110 vertical outlet. Grade 316. Channel Profile 3081. 150 wide with 144 wide perforated plate gratings, 2 thick turned to 30 effective depth, 40 x 6 slots at staggered centres. Built-in fall from 50 head depth to Type 5150 gully with basket, trap and 110 vertical outlet. Grade 316. Manhole Cover Type 4300. Vinoseal clamping flange, double sealed, screw down, clear opening 600 x 600. Complete with lifting handles. Grade 316.
PHARMACEUTICAL:	<i>Channel Profile 3010.</i> 250 wide with 200 wide smooth square mesh gratings 23 x 23, 30 x 2. Head depth 50 with built-in fall to Type 5300 height adjustable gully with basket, trap and 110 side outlet. Grade 316. <i>Washdown Gully Type 5300</i> height adjustable with 23 x 23, 30 x 3 smooth grating, basket, trap and 110 side outlet. Grade 316.



Halesfield 10, Telford, Shropshire, TF7 4QP.

01952 588488
sales@componentdevelopments.com

Company registration: 892102
VAT number: 159 2898 12