

faral sill line Technical Specifications

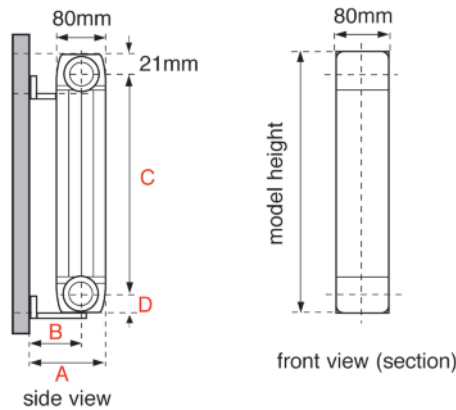

Model Height mm		242	292	245	395
Model Reference		FF2-100	FF3-100	OT2-100	OT3-100
Section Length mm		80	80	80	80
Total Length of Radiator mm		Total number of sections x 80mm + 20mm			
Section Depth mm		100	100	100	100
Wall to front of Radiator rmm	Ref A	125	125	125	125
Wall to pipe centre mm	Ref B	75	75	75	75
Tapping Centres mm	Ref C	200	350	200	350
Pipe Centres mm	Ref D	21	21	21	21
Connection Dia		1/2" Standard or 3/4" Optional			
Water Content (Litres per section)		0.15	0.20	0.40	0.45
Dry Weight (Kg per section)		1.05	1.44	1.16	1.20
Maximum working pressure		10 bar	10 bar	10 bar	10 bar
Standard Colour		RAL9010	RAL9010	RAL9010	RAL9010

Technical Data

Model Flat Front	Depth mm	Height mm	Centres mm	Length mm	Connection diameter inches	Water content lt/section	weight kg/section	Heat output EN442 ΔT = 50K watt/element	Heat output EN442 ΔT = 40K watt/element	Heat output EN442 ΔT = 30K watt/element
FF 2-100	100	242	200	80	½" or ¾"	0,15	0,69	59	44	31
FF 3-100	100	392	350	80	½" or ¾"	0,20	0,92	90	66	44

Model Open Top	Depth mm	Height mm	Centres mm	Length mm	Connection diameter inches	Water content lt/section	weight kg/section	Heat output EN442 ΔT = 50K watt/element	Heat output EN442 ΔT = 40K watt/element	Heat output EN442 ΔT = 30K watt/element
OT 2-100	100	245	200	80	½" or ¾"	0,16	0,59	56	43	31
OT 3-100	100	395	350	80	½" or ¾"	0.20	0,77	87	67	58

Radiator Lengths

FARAL radiators are supplied in a maximum length of 15 pre joined sections for ease of transport, each 15 section radiator can quickly have other radiators joined to it on site with two nipples and a joining key, a joining key will pass through an 8 section radiator so for example a 31 section radiator could be supplied as a 15 section with two 8 section radiators.