



**Avon Barrier**

## Avon RB880CR Defender Road Blocker



**Avon RB880CR Defender Shallow Road Blocker** provides a high level of protection where deeper foundations are not possible / practical.

With a shallow foundation the RB880CR is designed to complement the Avon Barrier range of Hostile Vehicle Mitigation (HVM) solutions. The RB880CR road blocker can withstand direct impact forces of 1,852 KJ, providing shallow mounted protection to sites from extreme Vehicle Borne Improvised Explosive Device (VBIED) attack.

The blockers were developed by our in-house engineering team to overcome specific site limitations and using the experience gained with the design, testing and production of the RB780CR Road Blocker, RB880CR is an additional highly dependable security product that will easily interface with a wide range of control equipment.

Units are assembled in our fabrication facilities using heavy gauge materials to give maximum strength and durability. This makes the RB880CR an ideal product to protect high security establishments, iconic buildings and critical infrastructure where existing underground services or other depth restrictions are an issue.

The RB880CR has been independently physically tested in a number of full scale crash tests conducted in accordance with PAS68 by the Transport Research Laboratory (TRL). This led to the RB880CR Defender Road Blocker becoming the first British built shallow foundation road blocker installed by the British Government.

### Features

- Multiple testing (4 different independent tests)
- Road blockers shallow foundation / mounting from 300mm overall depth
- Physically impact tested to PAS 68 criteria
- Manufactured from heavy gauge materials
- Manual hand pump facility
- Programmable logic control system
- 100% duty cycling

### Benefits

- Comprehensive understanding of attack resistance
- Overcomes site depth restrictions
- Confidence in proven performance
- Strength and durability
- Operational under power failure conditions
- Flexibility to interface with all forms of access control
- Reliable and dependable

**Hostile Vehicle Mitigation**

[sales@avon-barrier.co.uk](mailto:sales@avon-barrier.co.uk)  
Tel: +44 (0) 117 953 5252

# Technical Specification RB880CR Defender Road Blocker

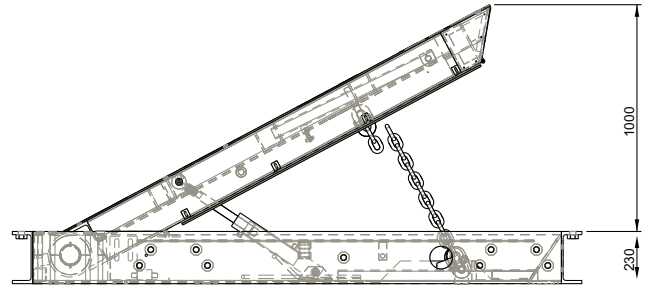
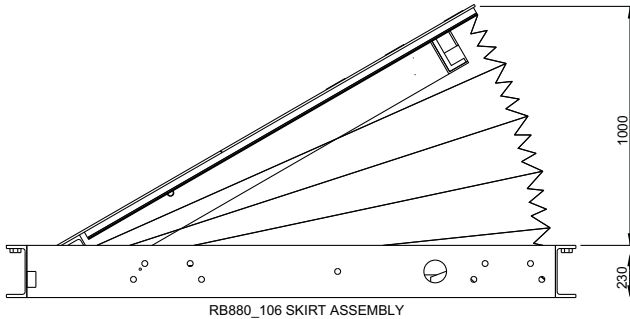

The blocker comes with a push-button control as standard, however it can be customised to interface with a wide range of access control equipment to suit specific customer requirements (available as options) and any configuration including (but not limited to) inductive loop systems, card readers, communication equipment and manned guard emergency systems can be accommodated.



## Technical Details

Physical Dimensions:	HPU Cabinet - 640/940mm W x 670mm D x 1300mm H Road blockers - 2520mm W x 2210mm D x 240mm H
Basic Power Requirements:	3-Phase 415V AC, 50Hz, (other voltages are available)
Control Voltage:	S.E.L.V 24v
Performance:	Loading 20 Tonnes
Impact Absorption:	1852KJ (fully operational immediately after impact)
Full PAS68 Classification:	V/7500(N2)/48/90:0/0 & V/7500(N2)/80/90:0/0
Tested Model:	1mHx2.0mW
Speed of Operation:	6 Seconds to raise or lower
Emergency Fast Raise:	<1 second to raise
Operating temperature range available:	-25°C - +70°C
Construction:	The supporting framework is constructed from fully welded, heavy gauge, high strength structural steels. Foundation support legs are provided to create a linked foundation enabling the impact forces to be distributed over a larger shallow area.

## Options Available

Where the blocker control point is remote from the installation, we strongly recommend the fitting of a recordable CCTV system, traffic lights and inductive loop systems. It is also recommended that a debris protection skirt is fitted.

For safety reasons pedestrians, cyclists and motorcycles are advised not to use a blocker controlled roadway, additional safety measures can be incorporated into the blocker system if required.

- Emergency fast raise system
- Emergency buttons with lock down
- Accumulator systems for hydraulic operation in power failure conditions
- Access and intercom systems
- UPS backup for the electrical system
- Interlocking systems to give air-lock type protection on sites with higher threat levels
- Inductive loop systems
- Traffic lights and back-indications systems
- Integral inset warning lights in blocking segment
- Debris protection skirt



Avon Barrier Corporation Ltd  
149 South Liberty Lane  
Ashton Vale Trading Estate  
Bristol BS3 2TL  
United Kingdom

Tel +44 (0) 117 953 5252  
Fax +44 (0) 117 953 5373  
Email sales@avon-barrier.co.uk  
www.avon-barrier.co.uk  
www.avon-barrier.com

Avon Barrier reserve the right to change or amend the specification of its products from time to time in furtherance of its policy of continued improvements.

Ref Avon RB880CR Defender Road Blocker version 2.7.14

