

**DELTA MEMBRANE SYSTEMS LTD**  
**DETAILING**

Date: July 2020



# CONTENTS

---

DELTA MEMBRANE SYSTEMS	03
A DELTA SOLUTION	04
SERVICES	05
TYPES AND GRADES OF WATERPROOFING	06
BRITISH STANDARDS	07
BS8102:2009 DESIGN PHILOSOPHY	08
EXAMPLES OF DEFECTS DUE TO POOR DETAILING	010
EXAMPLES OF GOOD DETAILING	011
DEFINITIONS OF DETAILING	012
ANTICIPATING DEFECTS	014
CONSTRUCTION JOINTS (INCLUDING MOVEMENT)	016
PIPE & SERVICE PENETRATIONS	022
CRACKS/HONEYCOMBING & CONCRETE DEFECTS	024
TIE BOLT HOLES	028
THRESHOLDS	030
UNDERPINNED DETAILS	032
FIXING THROUGH WATERPROOFING SYSTEMS	034
BEDDED STEEL BEAMS	036
ACTIVE LEAKS	038
ANCILLARY PRODUCTS TABLE	041
TECHNICAL DRAWINGS	042



# DELTA MEMBRANE SYSTEMS

---

Delta Membrane Systems Limited is the leading Type C Cavity Drain Membrane manufacturer in the United Kingdom. Our extensive range of waterproofing and damp proofing products are suitable for basement drainage and structural waterproofing (both for new build and existing structures) and in flood resilience.

Installing a Delta Membrane System offers complete protection to structures from ground water ingress and contaminants. Our products comply with British Standard 8102:2009 and are BBA Certified. Our dedicated technical team offer knowledge and experience in waterproofing design solutions, provide on-site assistance and advice throughout a project.

- Type C Drainage Protection in accordance with BS 8102:2009
- BBA Approved
- Suitable for new, existing and retrofit basement projects
- Ability to easily deal with aggressive ground water conditions
- "Grade 3" performance level (no dampness or water penetration acceptable)
- "Air Gap" Technology
- A reversible system, which will not create damage to historical or heritage structures
- Flexibility to cope in structures where movement or vibration issues can be problematic
- Virgin high density polyethylene studded/moulded sheet (HDPE)
- Easily applied to a variety of different substrates
- An effective barrier to the transmission of salts, liquid water and water vapour
- Suitable for Flood Resilience



# A DELTA SOLUTION

BS 8102:2009 (Code of Practice for Protection of Below Ground Structures Against Water from the Ground) recommends that every Design Team should incorporate a Waterproofing Design Specialist.

Delta Membrane Systems Limited has a dedicated team of Waterproofing Design Specialists. Our trusted Technical Team offer knowledge and experience and can provide expertise in structural waterproofing. As a Waterproofing Specialist Manufacturer, we work with architects, surveyors, contractors and engineers alike to provide a design service which complies with BS 8102:2009 and offers the highest level of technical expertise and assurance.



## BELOW GROUND WATERPROOFING SOLUTIONS FOR:

- Residential Buildings
- Commercial Buildings
- Retail Units and Warehouses
- Leisure Facilities
- Archives/Libraries/Vaults
- Hospitals
- Schools
- Underground Rail Stations and Tunnelling
- Underground Car Parking areas
- Listed Buildings
- Heritage Buildings
- Insulated formwork Construction

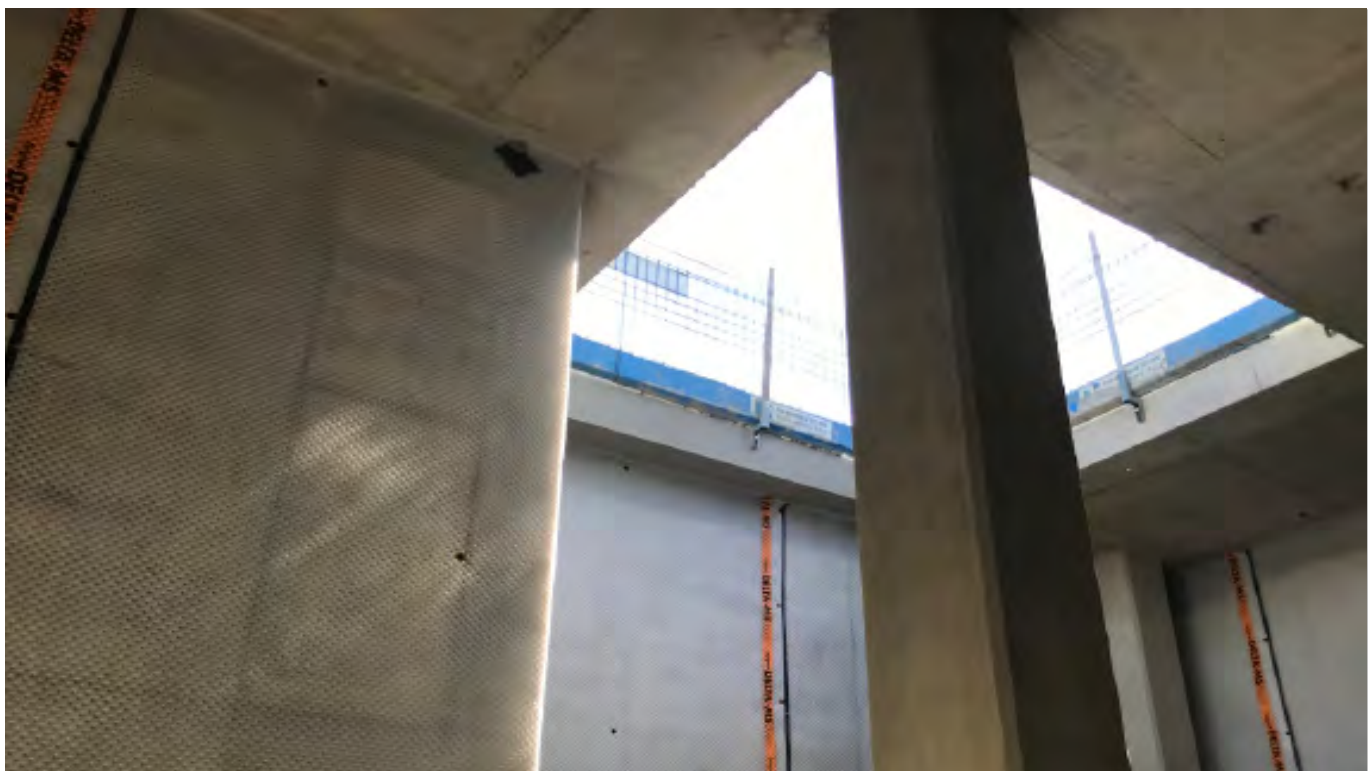



# SERVICES

## SERVICES

Delta Membrane Systems Limited provides a full range of waterproofing solutions suitable for all new, retrofit and refurbishment construction. With over 125 years of manufacturing experience Delta is an impeccable partner on every project. Our skills have been mastered through experience in the waterproofing industry. Delta's trusted Technical Team will help from concept to completion. Our hands-on approach and knowledge is what sets us apart.



### DESIGN SUPPORT

- Architecture knowledge
- Concept and waterproofing solutions
- Advice on design and best practice
- Custom solutions, as each project is unique in requirements
- Qualified CSSW staff (named on the Waterproofing Design Register)



### SPECIFICATION SUPPORT

- Detailed drawings including CAD
- Watertight and locking down structure concepts
- Specifications
- BIM
- NBS Plus
- RIBA Product Selector



### SITE SUPPORT

- Training and guidance offered at every step
- Technical Team attendance at site meetings
- Knowledge and experience
- Troubleshooting solutions



# TYPES AND GRADES OF WATERPROOFING

There are many different approaches to structural waterproofing. The construction methods will in part contribute to the specification of types of waterproofing systems and may also determine the overall structural waterproofing strategy.

Structural waterproofing falls into 3 categories:

**Type A** – Barrier Protection

**Type B** – Structurally Integral Protection

**Type C** – Drained Protection

With 3 grades:

**Grade 1** – Some water seepage and damp are tolerable depending on the intended use

**Grade 2** – No water penetration is acceptable

**Grade 3** – No dampness or water penetration is acceptable and dehumidification

## Residential/Commercial Basements

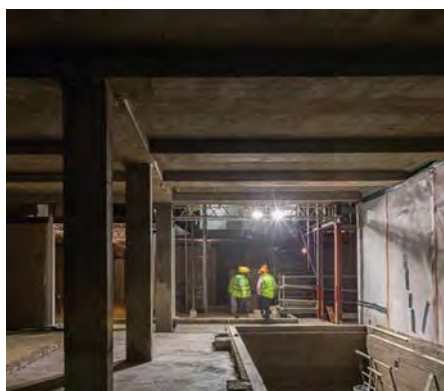

## Car Parks



## Museums and Heritage



## Hospitals

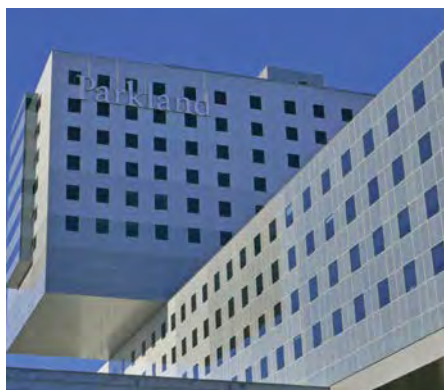

## Schools



## Hotels

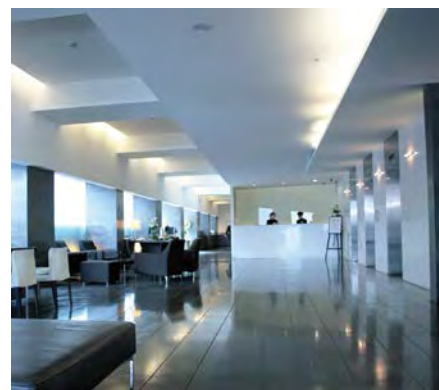

## Infrastructure Projects



## Railway and Tunnelling



## Libraries





# BRITISH STANDARDS

## BRITISH STANDARDS

Established in 1901 the BSI Group (formerly the Engineering Standards Committee), sought to standardise the types of steel manufactured in Great Britain in order to assist with competitiveness and efficiency.

Over decades these standards have been developed to cover numerous aspects of the engineering/building sector including engineering methodologies, quality, safety, systems and security.

### BS 8102:2009

British Standard 8102 'Code of practice for protection of below ground structures against water from the ground' was first publicised in 1990 with the second edition being publicised in November 2009. BS 8102:2009 supersedes BS 8102:1990 and CP102.

BS 8102 is a standard designed to protect the consumer. BS 8102 has been formulated to ensure the correct waterproofing solution has been selected and adhered to during the build process.

BS 8102 covers (but is not limited to):

- Cavity drain
- Cut-off wall
- Damp area
- Embedded retainer wall
- Ground barrier
- Loading coat
- Perched water table
- Seepage
- Tanking
- Barrier protection
- Vapour
- Waterproofing
- Waterproofing barrier
- Waterproofing system
- Water resistance
- Waterstop
- Water vapour
- Water vapour resistance



### NHBC CHAPTER 5.4 OFFERS A CHOICE OF STRATEGIES:

- Design Standards
- Statutory Requirements
- Load-bearing Structure
- Principles of Design
- Structural Deck
- Thermal Insulation and Vapour Control Layers
- Waterproofing and surface finishes
- Rainwater Drainage
- Guarding to Balconies
- Access for Maintenance
- Provision of Information

# BS8102:2009 DESIGN PHILOSOPHY

---

BS8102:2009 Code of Practice for the protection of below ground structures against water from the ground, provides guidance on the methods which should be adopted to deal with and prevent the entry of water from the ground into a structure that is below ground level.

It is widely referred to and used in basement waterproofing with reference to:

- Adoption of a design team
- Water table classification
- Defects and remedial measures

Our Design and Build Philosophy is quality driven, working with architects and trades alike, putting at the forefront construction considerations to ensure buildability, functionality, and maintainability. The result of this single approach is a consistent, complete, and quality design that is hard to equal.





# BS8102:2009 DESIGN PHILOSOPHY

---

In a world of hasty construction that can at times neglect attention to detail, we take pride in our passion to improve standards within the industry to develop solutions and successful installations which offer a life cycle to equal and beyond current expectations.

Delta's designs focus on a life-cycle oriented design philosophy, addressing life-cycle concepts and methods, deterioration and damage evaluation, life-cycle performance indicators, inspection and maintenance procedures all implemented in design practice. We work with our customers to establish a robust functioning design, this fine-tuning during the design processes reduces project failure.

Whether designing a waterproofing solution for a new home or reviving and modernizing an existing space, our designs are built to last and to be maintainable. By embracing the design-build model, we save our clients stress, time, and money; we can remove the bidding step from the construction process and work with our own well-established team of Registered Installers.

Our design philosophy embraces innovation and creating solutions that minimize client risk, foster collaboration, and partnership, and ultimately delivers the client with a waterproofing system which will resist to the passage of water. Well compacted concrete is inherently water resistant and with enough depth can effortlessly block water ingress from structures below ground. But why do so many concrete structures leak? It is not the concrete, which is leaking but areas such as service penetrations, cracks/joints/ducts which are not adequately waterproofed which allow for water ingress. Much of the failure associated with structural waterproofing is attributed to insufficient consideration of details within the waterproofing design.

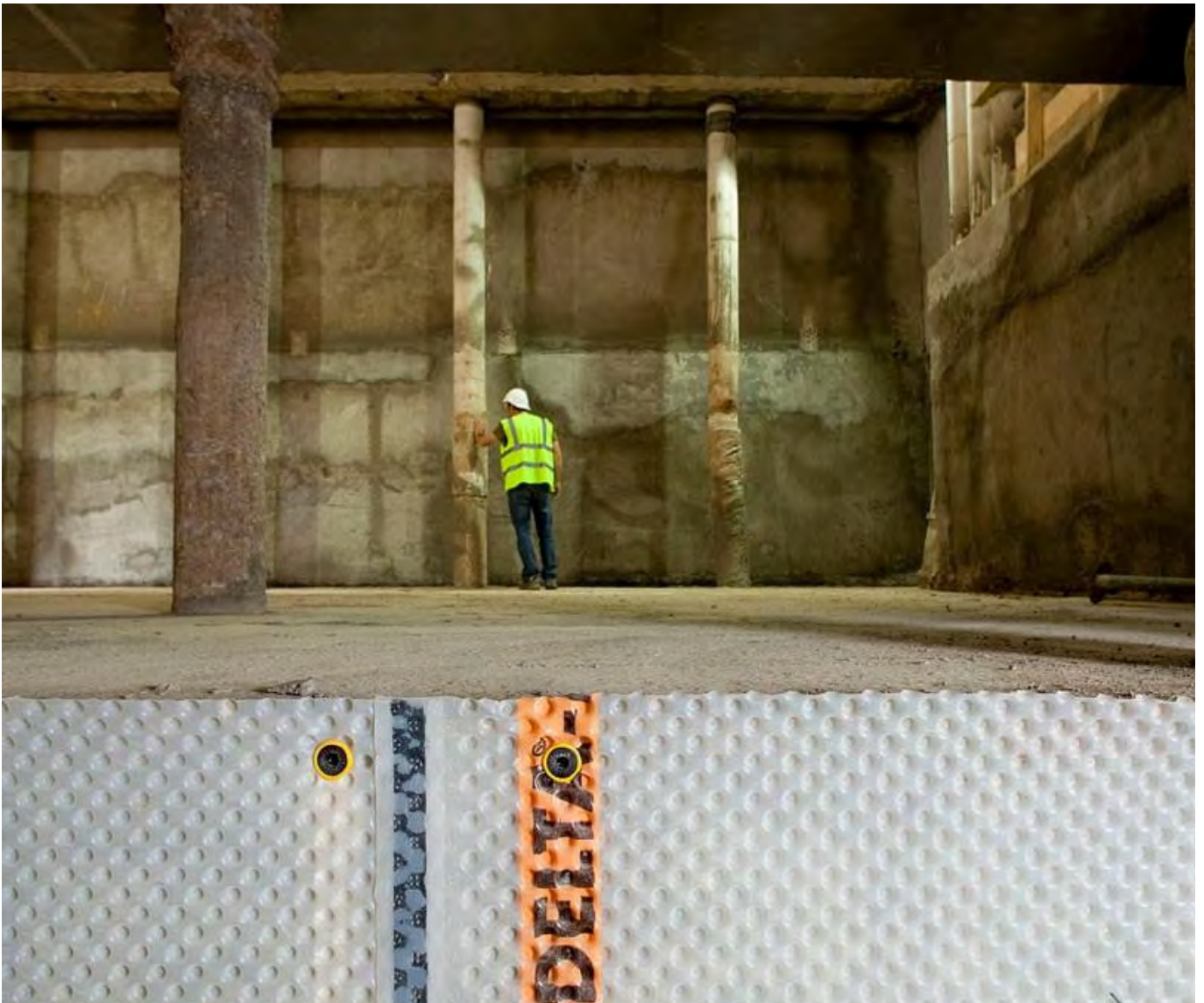



# EXAMPLES OF DEFECTS DUE TO POOR DETAILING

---





# EXAMPLES OF GOOD DETAILING

---



# DEFINITIONS OF DETAILING

---

## Active Leak

Water penetration through a structure/substrate at a current time.

## Capillary break

A hydrophobic material or non-porous material (such as plastic, metal or glass) or gap between parallel layers of material (often less than 1/16" or 1.5 mm) sufficient to stop capillary action.

## Cold Joint

A cold joint is the boundary between concrete steps for example the wall/floor joint.

## Construction Joint

A construction joint is a concrete joint formed in-situ that is used when a new section of concrete is poured adjacent to another concrete section that has already set or interfacing between masonry or other building materials. Construction joints allow for some horizontal movement, while being rigid against rotational and vertical movement.

*A construction joint is essentially a planned crack and a Crack is an unplanned joint.*

## Contraction Joint

A contraction joint is formed, sawed, or tooled groove in a concrete structure to create a weakened plane to regulate the location of cracking resulting from the dimensional change of different parts of the structure.

## Crack Repair

Methods for repairing cracked walls/floors and ensuring that they are watertight.

## Dummy Joint

A dummy joint is a predetermined breaking point. Usually a groove cut into the top half of a concrete slab, sometimes packed with filler, to form a line where the slab can crack with only minimum damage.

## Expansion Joint

An expansion joint is a planned joint which is designed to allow two sections of concrete or masonry to expanding and contract.

## Floor/Wall Junction

An area where the wall meets the floor/slab in construction.





# DEFINITIONS OF DETAILING

---

## **Firebreak**

Products used to provide fire protection by the sealing of linear gaps, service penetrations, movement joints and other necessary openings in fire separating wall and floors.

## **Load-Bearing Wall**

A load-bearing wall or bearing wall is a wall that is an active structural element of a building, it bears the weight of the elements above wall. Load-bearing walls are one of the earliest forms of construction.

## **Kicker**

A Kicker is small (5-15cm) step/concrete up stand cast above the slab/foundation/floor to position the coordinates for a column or wall formwork for the next construction level.

## **Movement Joint**

A movement joint is a planned joint which is designed to permit relative movement caused by expansion due to changes of temperature or moisture.

## **Pressed Joint**

A pressed joint allows for the transfer of pressure, transverse displacement can be avoided with an interlocking geometry.

## **Reveals**

Reveals are the distance or measurement from the face of a door/window out to the face of the frame on the push side.

## **Service Penetrations**

Service penetrations are created using a cast-in-place sleeve, in a wall or floor assembly, for the purpose of accommodating the passage of a mechanical, electrical or structural service.

## **Settlement Joint**

Settlement joints are joint between adjacent parts of a building, structure, or concrete that permits the adjoining masses to settle at slightly different rates.

## **Unplanned Movement Joint**

An unplanned movement joint can be the cause of shrinkage, creep, thermal movement or to accommodate movement with temperature changes.



# ANTICIPATING DEFECTS

---

Consideration to how defects may be created (from human error to design fault) and the subsequent effects of these defects in how they affect a structure is a great starting block to focus on the positives of how to avoid the creation of defects.

A construction defect is generally a deficiency in the design or the construction. A small construction defect can be destructive and lead to damage. However, it is not always possible to detect this defect until after construction. While some defects are obvious from the onset, most are not detected until years after finishing the structure, in the case of waterproofing, when water ingress occurs.

Many causes combined within a project may lead to defects. However, there are some common factors that are counted as the main contributors to waterproofing defects on site. For example, inexperienced workmanship, inaccurate measurement, inferior materials and ineffective communication.

Are zero defects achievable?

Is it impossible to factor out defects in construction?

We believe that the waterproofing sector can achieve near zero defects, by adopting successful waterproofing techniques along with correct built philosophy and utilising best practices will influence the success of a project.

It is crucial that all involved in a project should care and that a structural waterproofing consultant should be appointed at the onset of a project.

A structural waterproofing consultant is a specialist usually appointed in a project to provide information and guidance relating to the design, installation and maintenance of a structure's waterproofing system.

Risk management is a particularly important part of the structural waterproofing consultant's role and the structural waterproofing consultant will have a wealth of knowledge regarding anticipating defects.

The benefits of appointing a structural waterproofing consultant is that they are specially qualified and experienced in creating solutions to prevent water ingress and can work within any constraints within a project.

With all types Delta waterproofing systems, it is recommended that contractors, such as Delta Registered Installers who are trained and experienced in the Delta systems are used for installation.

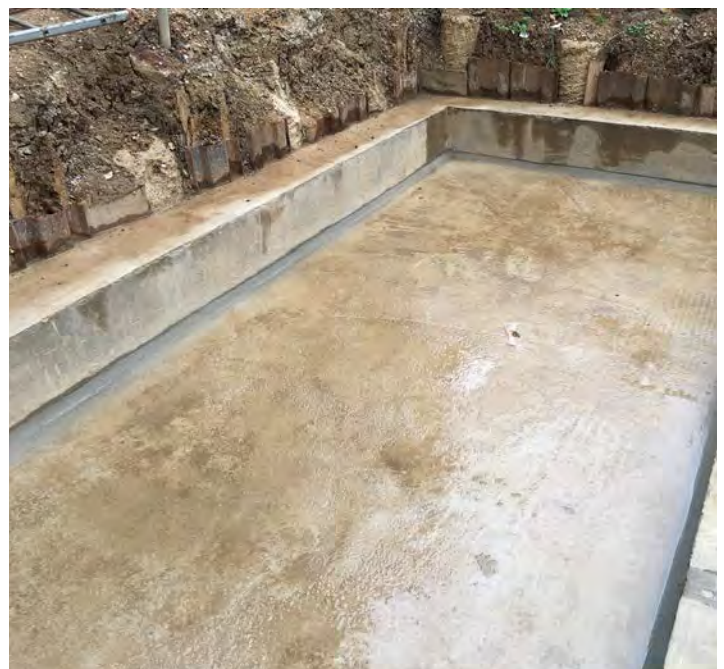
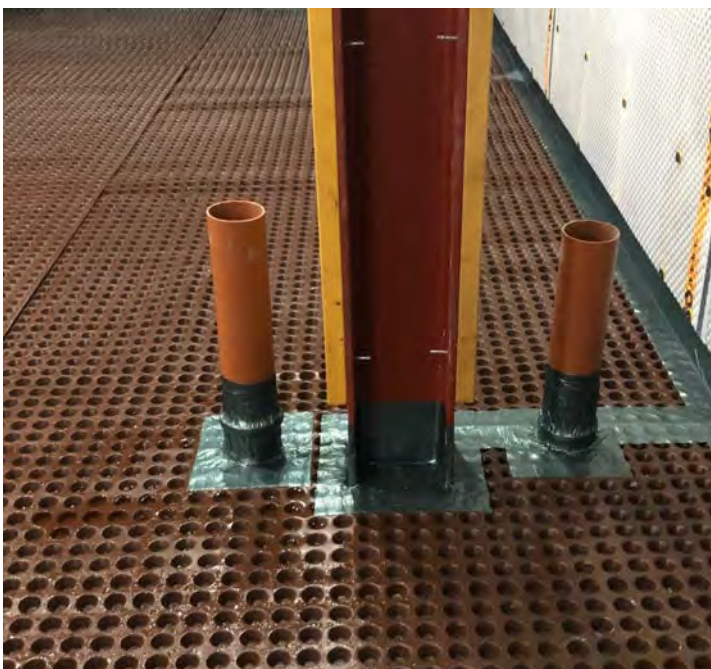



# ANTICIPATING DEFECTS

## WHAT ARE COMMON DEFECTS IN BELOW GROUND STRUCTURES?

Common defects within structural waterproofing systems are estimated to cost £25 million per annum in the United Kingdom.

Full site investigations are important when mitigating and reducing risk in waterproofing design. The results will have a bearing not only on the design but on the waterproofing system itself. Whilst findings of a site investigation are often seen as conclusive, it needs to be remembered that this is just a 'snapshot in time'. It should be assumed that water will come to bear against the full height of the below ground structure at some time in its life.

The system designed maybe acceptable at the time of construction meeting the 'snapshot in time' investigations, however this system may not be adequate for environmental changes of the future.

### Natural causes for waterproofing failure:

- Changes in water tables
- Changes in hydrostatic pressure
- Thermal changes
- Dynamic Movement
- Heave
- Subsidence
- Clay soils
- Changes in environment
- Stress
- Changes in ground drainage
- Structural stability

### Human error causes for waterproofing failure:

- Lack of maintenance
- Poor installation
- Inappropriate materials installed
- Incorrect/wrong choice systems specified
- Bad placement of reinforcement
- Poorly compacted concrete/ Honeycombing of concrete
- Poor detailing
- Poor design
- Damage to the waterproofing system
- Cracks to concrete
- Crystallization in concrete
- Concrete defects at joints



# CONSTRUCTION JOINTS (including Movement)

---

Generally, a construction joint is where two placements of concrete meet, typically daywork joints in concrete, where one pour ends and another begins. These joints are placed at regular intervals to prevent the future development of cracks. The design of the joint is important for the overall design to function of a structure. Design and construction should be kept as simple as possible. When waterproofing joints, an important consideration is that the material is suitable for the expected amount of movement within the structure.

## Types of movement:

- Shrinkage – Initially rapid, less severe as the concrete ages
- Creep – A phenomenon which causes a redistribution of stress away from points of intensity
- Thermal movement – Expansion and contraction of the structure with temperature changes

The success of joint waterproofing starts at the conception stage. The product used to waterproof joints must offer a permanent and flexible seal, allowing for movement without increasing damage in the event of movement. Construction Joint waterproofing can be incorporated at the design stage or retrofitted for failed systems.

## Associated Products:

- Koster Quellband (Water Bar)
- Koster IN 5
- Koster Flex Tape 20 & 30
- Koster KB Pox Adhesive
- Koster FS-H
- Koster FS-V
- Koster Primer 2C
- Koster PU 207
- Koster NB 1
- Koster Repair Mortar Plus
- Koster Injection Tube (Hose)



## QUELLBAND (Water Bar)

Koster Quellband is used as a waterstop in concrete construction joints. The robust strip is simply nailed onto an existing joint face before the consequent concrete pour. Any leakage through the joint activates the Quellband.

- Alkalinity activated - stops premature swelling on contact with water
- Easy application
- No special tools are needed
- Permanent seal of the joint after swelling - fills all voids and cracks in the concrete
- Easy to use, non-sticky surface even at high temperatures
- No material fatigue - swells even after years



# CONSTRUCTION JOINTS

---



## KOSTER IN 5

Koster IN 5 is a solvent-free, low viscosity, 1 component polyurethane for permanently and elastically injecting, filling, and sealing cracks and construction joints. Koster IN 5 does not react aggressively when coming into contact with steel or iron, enabling a corrosion protection to be achieved. Due to its slow reaction, the material can be processed for up to 4 hours.

- Permanently seals and bridges cracks, joints and restores structural integrity
- Does not react aggressively with steel or iron
- Easy, seamless application
- Fast curing
- Suitable for new construction and repair on existing structures

---

## KOSTER FLEX TAPE 20 & 30

Koster Joint Tape 20 (Elastic sealing tape for waterproofing joints and irregular cracks, 1 mm x 200 mm) and Joint Tape 30 (Elastic sealing tape for waterproofing joints and irregular cracks, 1 mm x 300 mm) are thermoplastic tapes for sealing and bridging expansion and dilation joints (up to 12cm) and broad, irregular cracks.

- Thermoplastic tapes
- Suitable for sealing and bridging expansion and dilation joints
- Suitable for sealing irregular cracks
- UV resistant
- Highly elastic and can withstand extreme movements of joints
- Used in conjunction with Koster KB Pox adhesive



# CONSTRUCTION JOINTS

---



## KOSTER KB POX ADHESIVE

Koster KB Pox Adhesive is a high performing, 2 component epoxy adhesive specifically produced for securing Koster Joint Tape 20 and Joint Tape 30.

- 100% solid and is solvent free
- Suitable for dry, moist or wet substrates
- Thixotropic material creates immense adhesive strength
- Suitable for concrete, mortar, metal, wood & a wide range of other building materials
- Robust strength promptly
- Suitable for vertical and horizontal application

## KOSTER FS-H

Koster Joint Sealant FS-H is a polysulphide-based elastic, pourable joint sealant for sealing joints in horizontal areas. When fully cured, has a high mechanical load capacity, good resistance to water, sea water, salt solutions, benzenes and mineral oils. It is root resistant, does not rot and it has exceptionally good retraction properties.

- Suitable for construction and movement joints
- High ability to cope with high mechanical stresses
- Permanently and elastically seal horizontal joints
- Pourable/self-levelling joint sealant
- Available on Delta "How To" Video Guides
- Good resistance to water





# CONSTRUCTION JOINTS

---



## KOSTER FS-V

Koster Joint Sealant FS-V is a flexible stiff/creamy polysulphide joint sealant. When fully cured, is a rubbery elastic sealant with a high mechanical load capacity, good resistance to water, sea water, salt solutions, benzenes and mineral oils; it is root resistant, does not rot and it has very good retraction capabilities.

- Can be used to permanently, and, elastically seal vertical joints
- High mechanical load capacity
- Easy application
- Available on Delta "How To" Video Guides
- Good resistance to water, salt solutions, benzenes & mineral oils
- Great retraction capabilities

## KOSTER PRIMER 2C

Koster FS Primer 2C is a bonding agent for Koster Sealants FS-H & FS-V. FS Primer 2C is a 2 component, brush applied transparent fast curing primer.

- The two components are mixed, until homogenous consistency is achieved
- This Primer is Brush applied to joint prior to the installation of FS-H or FS-V
- If the substrate is porous a second coat of primer will be required
- Joint should be free from grease, dirt and oils prior to use of FS Primer 2C
- Curing time Approx. 30 minutes
- Application temperature 5 °C – + 30 °C



# CONSTRUCTION JOINTS

---



## KOSTER PU 907

Koster PU 907 is designed for civil and industrial movement, expansion, control and dilatation joints in architectural and heavy construction. Koster PU 907 is a highly elastic, one component, low modulus polyurethane joint sealant. This remarkable sealant can be used for between concrete, mortar, brickwork, natural and synthetic stone, metal, steel, aluminium, wood, ceramic tiles and rigid plastics.

- Restores moisture to create flexible sealants, for overpainting after curing
- Highly thixotropic with positive workability
- Excellent adhesion to typical construction materials
- Easy application using a silicone gun
- Seamless Application
- Non-Sagging

## KOSTER NB 1

Koster NB 1 is a crystallizing mineral waterproofing slurry system for sealing against pressurized water (> 13 bar). Containing crystallising and capillary-plugging agents, protection of cementitious renders or concrete with cracks due to shrinkage and against water infiltration. Whilst offering protection of structures with an inadequate layer of concrete over the reinforcement rods against the penetration of aggressive elements.

- Crack bridging material
- Protection of cementitious renders or concrete with cracks due to shrinkage and against water infiltration
- Protection of concrete pillars and beams against the penetration of carbon dioxide
- Protection of structures with an inadequate layer of concrete over the reinforcement rods against the penetration of aggressive elements
- Flexible protection layer of new concrete structures or repaired structures.





# CONSTRUCTION JOINTS

---

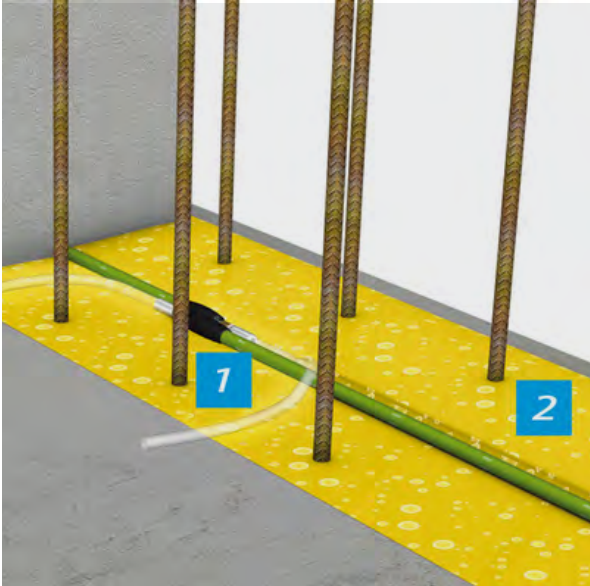

## KOSTER INJECTION TUBE (HOSE)

Injection hoses are installed in the middle of the wall in lengths of approximately 10 to 15 m. The minimum concrete cover must be 8 to 10 cm. The injection hoses must be in continuous contact with the concrete substrate. The sealing caps of the holder boxes must be flush with the surface of the formwork and remain accessible. No injection should take place within the first 28 days of the concrete being cast.

The injection is carried out using customary low-pressure injection systems in conjunction with suitable injection ports, (packers). When using a single component pump, no moisture may meet the injection material during the application. The injection hose is filled until material comes out of the other hose end. That end of the hose is then sealed and material is injected until the gauge pressure on the injection pump remains constant. Make sure to protect the surrounding work area from injection resin that may be discharged from the wall, packers, drill holes, etc. Do not stand directly behind the packers during injection.



# PIPE & SERVICE PENETRATIONS

---

Building services allow the structure to operate and do what it was mean to do, structures require pipes, ducts and cables to pass through it in unseen voids through walls and floors. During the design stage, a Waterproofing Design Consultant should consider how these services are going to enter the structure and creatively apply design principles to design a continuous waterproofing system.

From drainage pipes, gas mains to electrical wires all will need appropriate consideration to avoid dire consequences of waterproofing fail.

BS8102:2009 sets out many types of sealing solutions across all types (A, B & C) of waterproofing systems. The type of sealing system must be suitable for the waterproofing solution. From new to retrofit design principles will include products which offer a failsafe continuous waterproofing solution.

## Associated Products:

- Koster Quellband (Water Bar)
- Koster KB Flex
- Puddle Flanges
- Koster Repair Mortar Plus
- Delta Cornerstrip



## KOSTER KB FLEX 200

Koster KB-Flex 200 is a permanent plastic sealing compound ideal for sealing pipe and cable penetrations, cavities and for custom detail waterproofing solutions against moisture and pressurized water.

- Waterproof sealing compound
- Watertight finish
- Ideal solution for sealing pipe and cable penetrations
- Does not dry out
- Can be applied to dry, moist or wet substrates
- Immediate functionality
- Can be used internally and externally on concrete, brickwork, blockwork or masonry
- Non shrink



# PIPE & SERVICE PENETRATIONS

---



## DELTA PUDDLE FLANGES

A puddle flange offers an effective solution against water penetration around service pipes. Incorporating a puddle flange into designs ensures a watertight seal is offered where pipes pass through concrete structures (i.e. the walls of any structure below groundwater level and in flood resilience designs).

Pipes passing through concrete will not bond to the concrete and water can pass long the external surface of the pipe, a puddle flange will act as a barrier to this flow. The seal body within the puddle flange is compressed during the concrete pouring process, should the concrete shrink during curing the rubber relaxes and maintains a seal against any flow path. A puddle flange is recommended for use around any pipe penetration in a below ground structure. Puddle flanges are available in various sizes from 32mm up to 160mm.

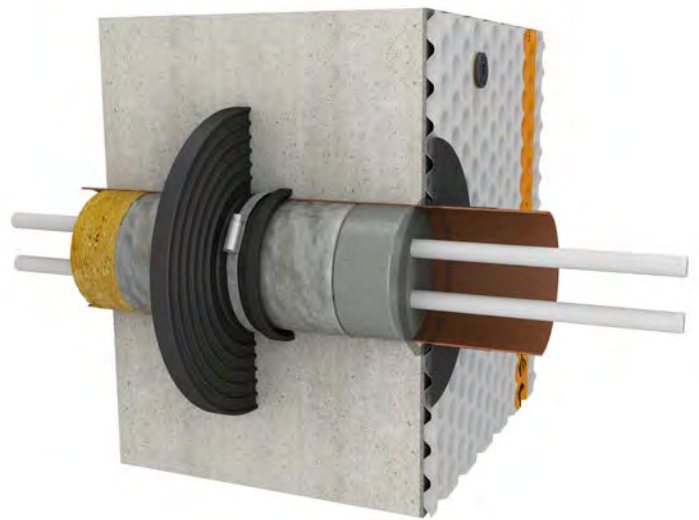
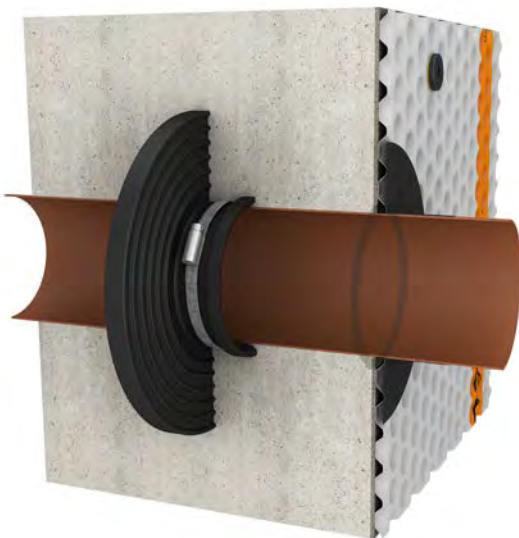

# CRACKS/HONEYCOMBING & CONCRETE DEFECTS

---

Every waterproofing design should allow for defects owing to poor workmanship, inappropriate use of materials and defects owing to specific properties within the materials used to create the structure. Waterproofing systems for below ground structures are opposed with stringent requirements regarding durability, exposure and stress conditions.

To establish a waterproof structure when using concrete, its essential to follow good concrete practices. The importance in ensuring concrete is fully compacted and cured should be a fundamental element.

Project failure can happen to any project. There are an infinite number of reasons for failure. In most cases, failure is controllable. There are many common pitfalls when it comes to designing a robust waterproofing system. Products do not fail! When failures occur, it is due to the design and build philosophy not being correct. The devil is in the detail – all waterproofing elements must be considered at the construction design stage to be durable and effective.

## Associated Products:

- Koster Polysil TG 500
- Koster Repair Mortar Plus
- Koster Betomor 88 Light
- Koster Z1 & Z2
- Koster Sewer & Shaft Mortar
- Koster Repair Mortar NC



## KOSTER POLYSIL TG 500

Koster Polysil TG 500 – is a deeply penetrating primer for damp, salt-containing substrates and an anti-lime treatment for new concrete which also acts as a liquid hardener for sealing slurries. Polysil TG 500 will not only reduce the amount of free lime leaching but will also improve the water resistance of the basement structure by absorption into the structure and locking in the free lime.

- 'anti lime' coating product specially blended with Polymers and silicates
- Brush or Spray application
- Can be used to strengthen and to protect mineral substrates and to reduce their absorbency, even of such problematic building materials as sandstone
- Decreases the danger of new development of salt efflorescence, free lime egress, and raises the resistance of mineral substrates to freezing and thawing
- Can also be used to harden sealing slurries
- Can be used as a surface primer for Koster waterproof Coating



# CRACKS/HONEYCOMBING & CONCRETE DEFECTS

---



## KÖSTER BETOMOR MULTI A

Koster Betomor Multi A is a shrink free, waterproof, light mortar with exceptionally low density for repairing and reprofiling concrete and screed surfaces.

- For filling, repairing and reprofiling of fractured or broken concrete areas
- Low Density
- Should be applied in 2 coats
- Shrink-free
- Easy application
- Allows for a continuous system

## KÖSTER Z1 & Z2

Koster Z1 and Z2 are polymer modified, mineral corrosion protection coatings for reinforcement steel. Before use reinforcement steel must be cleaned before this bonding agent is applied.

- Brush applied to cleaned steel
- Koster Z1 is grey in colour for visual control of application
- Koster Z2 is red in colour for visual control of the application
- Fast curing time
- Protects reinforcement steels prior to the application of to Betomor Multi A
- Continuous system



# CRACKS/HONEYCOMBING & CONCRETE DEFECTS

---



## KÖSTER SEWER & SHAFT MORTAR

Koster Sewer and Shaft Mortar is a watertight, fast curing and fast setting restoration mortar for sewers and shafts. Sewer and Shaft Mortar is fibre reinforced and develops a high compressive strength. Sewer and Shaft Mortar can be applied below the waterline even under flowing water. Sewer and Shaft Mortar can be used for the watertight repair, renovation and touch ups of sewer and shaft systems, as well as for levelling and filling of breakouts up to 3 cm per layer.

- Excellent Workability
- Suitable for relevant repair and touch up of sewers and shafts
- Easy, seamless application
- Useable on all stable, hard mineral substrates
- Substrate must be open pored
- High compressive strength

## KÖSTER REPAIR MORTAR NC

Koster Repair Mortar NC is a fibre reinforced repair, concrete replacement and finishing mortar with high chemical and mechanical resilience. It has a high adhesion to old and new mineral building material substrates. Koster Repair Mortar NC can be used for structurally relevant repair and touch up of voids, and for levelling of concrete defects.

- Can be applied to all concrete substrates
- High chemical and mechanical resistance
- High compressive strength
- Suited as substrate preparation for corrosion protection
- Easy application
- Continuous application





# CRACKS/HONEYCOMBING & CONCRETE DEFECTS

---

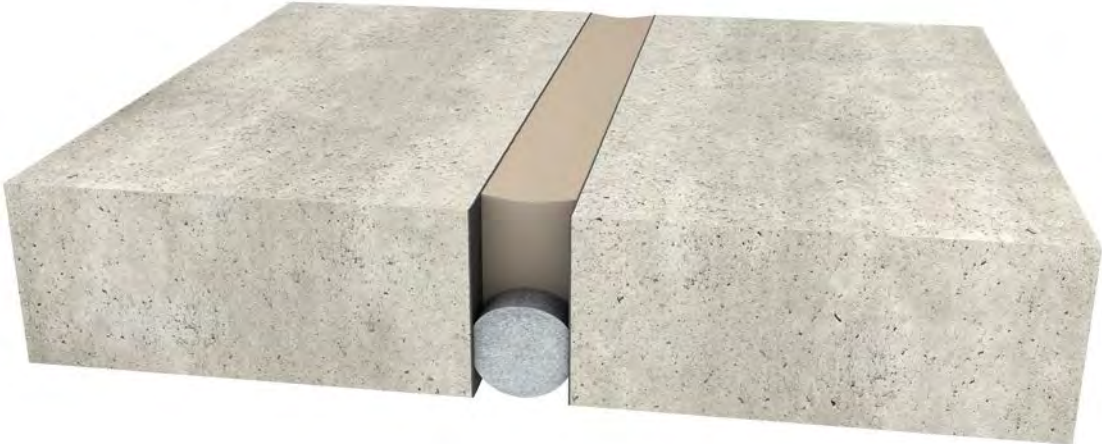

# TIE BOLT HOLES

---

Casting concrete is a crucial task in construction and requires great planning and accuracy, in addition to a proper execution sequence. Tie bolt holes (shutter bolt holes) are often forgotten when it comes to continuous waterproofing systems. Used when pouring reinforced concrete these bolts, which keep shuttering in place, will often need waterproofing retrospectively once the concrete has cured.

It is fundamental that all waterproofing elements of a structure are communicated with all parties throughout the construction process. For this reason, the waterproof design should take into consideration the construction stages and timing between them to ensure a continuous waterproofing system is installed/applied during the correct stages.

## Associated Products:

- Koster Repair Mortar Plus
- Koster KB Flex



## REPAIR MORTAR PLUS

Koster Repair Mortar Plus is a watertight, fast setting, slightly expanding repair mortar with excellent adhesion (even to old building material substrates). With the addition of Koster SB Bonding Emulsion, it can be used as a PCC (polymer-modified cement concrete) mortar.

- Watertight (Positive and negative side waterproofing)
- Fast Setting (Seamless, easy application)
- Slightly expanding
- Excellent adhesion
- Can be applied to all mineral substrates
- Suitable for watertight repairs and touch ups to substrates
- Can be used internally and externally on concrete, brickwork, blockwork or masonry



# TIE BOLT HOLES



## KOSTER KB FLEX

Koster KB-Flex 200 is a permanent plastic sealing compound ideal for sealing pipe and cable penetrations, cavities and for custom detail waterproofing solutions against moisture and pressurized water.

- Waterproof sealing compound
- Watertight finish
- Ideal solution for sealing pipe and cable penetrations
- Does not dry out
- Can be applied to dry, moist or wet substrates
- Immediate functionality
- Can be used internally and externally on concrete, brickwork, blockwork or masonry

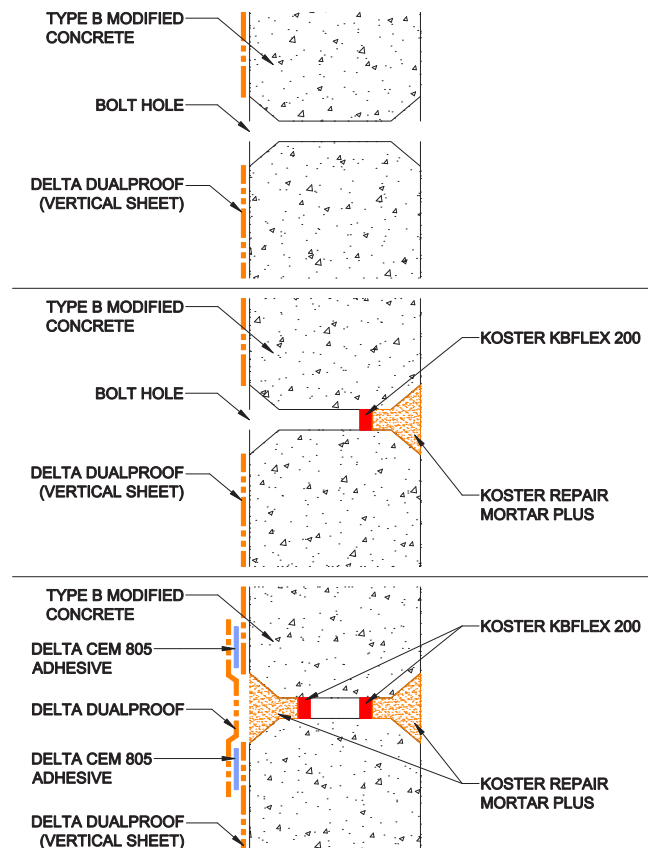

# THRESHOLDS

---

BS8102:2009 'Code of Practice for the Protection of Below Ground Structures against Water from the Ground', provides excellent guidance on design principles to ensure waterproofing systems are adopted to deal with and prevent the entry of water from the ground into a structure at below ground level. This guidance document is widely referred to and used throughout waterproofing industry.

It should be assumed that water will come to bear against the full height of the below ground structure at some time in its life cycle. It is important to carry the waterproofing system through beneath thresholds, rather than just terminating the waterproofing at the threshold. Also, to ensure good seals between the waterproofing system and the threshold below the plate (or timber seal), particularly where fixings are likely to penetrate the waterproof membrane.

## Associated Products:

- Delta High Performance DPC
- Koster NB 1
- Delta Cornerstrip
- Koster Repair Mortar Plus

---

## DELTA HIGH PERFORMANCE DPC

Delta High Performance DPC is a high performance polymeric material designed to suit all applications. Whether as a dpc at ground level, or for use as a fully designed cavity tray system, Delta DPC is designed to withstand the heaviest of loadings and is fully compatible with all materials it is likely to come into contact with during the normal course of construction and satisfies all the requirements as laid down by current British Standards.

Delta High Performance DPC is available in various thicknesses either for use in buildings up to four storeys or for use in buildings in excess of four storeys.

- Suitable for use as a DPC in all types of building construction
- Can be used in vertical, horizontal, stepped and cavity tray application
- Available in various thicknesses
- Excellent tear resistance under high compressive loads
- Low permeability to Radon
- Both faces feature a non-slip profile to ensure optimum mortar adhesion
- Bitumen-compatible, rot-proof and UV-stabilized
- Highly flexible even at low temperatures, so that no cracks will occur in the material



# THRESHOLDS

---

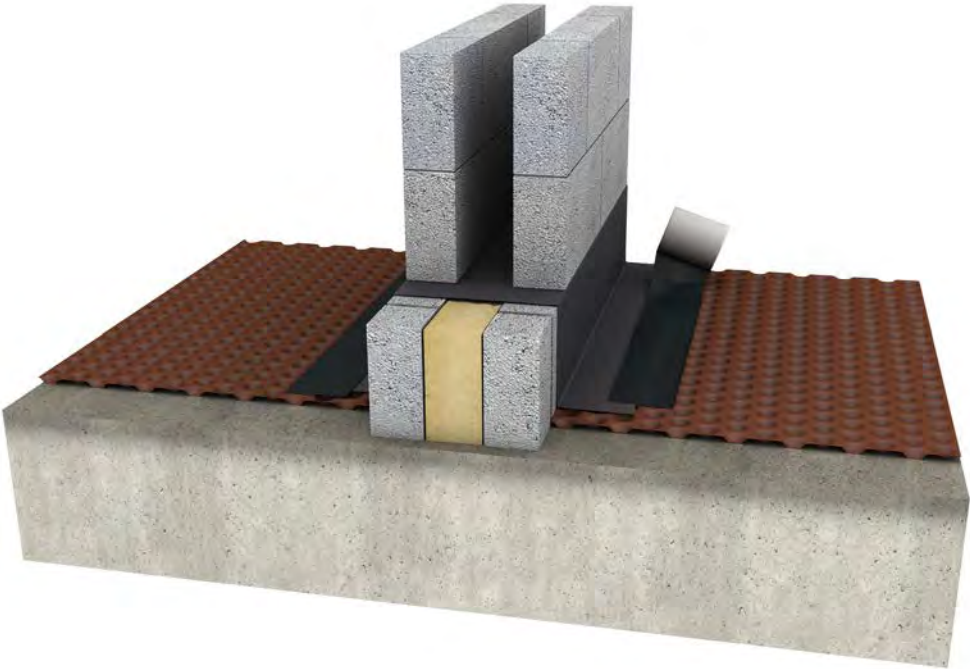



# UNDERPINNED DETAILS

---

BS 8004:2015+A1:2020, gives recommendations for the design, construction, testing, monitoring and maintenance of foundations in accordance with BS EN 1997. The foundation types covered include spread foundations, pile foundations (including helical pile foundations) and underpinning.

The term "Underpinning" means a solid foundation laid below ground level to support or strengthen a building. This process can sometimes be more economical, due to land prices or otherwise, to work on an existing structure's foundation than it would be to build a new one. There are several tried and tested methods to select from for how to achieve water tightness of these most critical of junctures below ground levels, which are notorious passages for water ingress when not adequately, or robustly detailed.

## Associated Products:

- Koster Waterstop
- Koster Polysil TG 500
- Koster Repair Mortar Plus
- Koster SB Bonding Emulsion
- Koster NB 1



## KOSTER WATERSTOP

Koster Waterstop is a fast curing, expanding plug and repair mortar. Waterstop can be used to seal water leakages in concrete, masonry and natural stone structures quickly. The material can also be used to form fillets which are subject to pressurised water, to seal slotted walls, manholes, cable and pipe penetrations, and to subsequently seal damaged pipe joints in canal construction even if they are exposed to pressurised water.

- Repairs to concrete and screeds
- Construction joint detailing
- Filling tie bolt holes in concrete construction
- Detailing to dry pack joints
- Watertight
- Ability to stop active leaks

# UNDERPINNED DETAILS



## KÖSTER SB BONDING EMULSION

Elasticizing synthetic-dispersion for universal use in mortars, plasters, sealing slurries and concrete. Koster SB Bonding Emulsion is a universally usable synthetic liquid for all cementitious mortars, plasters and sealing slurries. Koster SB Bonding Emulsion is solvent, plasticizer and filler-free. When added to mineral based systems, the synthetic liquid increases elasticity and flexibility and reduces water absorption. Koster SB Bonding Emulsion is waterproof which means that after its application it can neither be washed nor rained off.

- Positive and negative side waterproofing against pressurized water
- Can be used in all cases in which a good bond between mortars, plasters, sealing slurries, concrete and existing mineral substrates
- As an additive to mineral systems, the synthetic additive causes a strong increase in flexibility and elasticity and at the same time a reduction of the water absorption
- Improves the application properties and workability of fresh mortars
- Suitable for new construction and repair on existing structures

## DETAILING TO DRY PACK - FOR DELTA MS CAVITY DRAIN SYSTEM

1. Existing Masonry Wall
2. Dry Pack
3. KÖSTER Repair Mortar Plus
4. KÖSTER NB1 + SB Bonding
5. KÖSTER Polysil TG500 Anti-Lime Coating
6. DELTA MS 500
7. Concrete Pin

Drawing Note: This drawing is for illustrative purposes only. Drawing is NOT to scale. All installations to be carried out in strict accordance with manufacturer's installation instructions.

For further assistance contact Delta Technical on 01992 523 523 or email [technical@deltamembranes.com](mailto:technical@deltamembranes.com)



# FIXING THROUGH WATERPROOFING SYSTEMS

---

It is essential that care should be taken if with fixings through waterproofing systems. Not using suitable fixings or fixing through waterproofing systems without ensuring the fixings are waterproofed will compromise the continuous system and potentially could lead to a failed system.

Consideration must be made to ensure the continuity of fixings and repair of the same. They should be checked for compatibility with the waterproofing layer.

When selecting the correct waterproofing solutions, ensure you choose your construction materials and supply chains carefully and opt for one that will serve you well.

## For a continuous solution ensure:

- A reliable waterproofing system is selected
- The system is maintainable post installation
- That the system is compatible with the type of construction
- Simple and safe application

## Associated Products:

- Koster KB Fix 5
- Koster Repair Mortar Plus
- Delta Fix Adhesive



## KOSTER KB FIX 5

Koster KB Fix 5 is an extremely fast setting waterproof and weatherproof mortar for swift installations. KB Fix 5 swiftly fills holes and cracks in plaster and masonry and can be used for anchoring wall anchors, anchor fittings, brackets of roof gutters and down pipes, handrails, grates, radiators as well as for swift repairs at home, for sealing pipe penetrations in connection with Koster KB Flex 200.

- Fast setting
- Anchoring System
- Fast setting waterproof and weatherproof mortar
- Suitable for internal and external waterproofing



# FIXING THROUGH WATERPROOFING SYSTEMS

---



## DELTA FIX ADHESIVE

Delta Fix Adhesive is formulated as an adhesive for bonding & anchoring most building materials e.g. brick, stone, steel, mortar & timber. Suitable for fixing bolts and penetrations through waterproof coatings to provide a waterproof seal. Once cured Delta Fix Adhesive creates a strong stress free joint regardless of the surrounding environment.

- Delta Fix Adhesive is colour coded for visual assurance that the two components are fully mixed
- Solvent free
- Thixotropic
- Cures in cold, damp conditions
- Resin anchor system for fixings into masonry and concrete structures

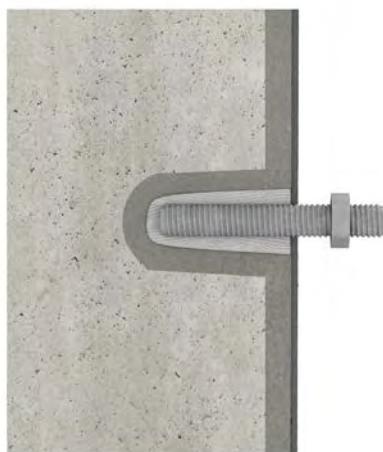

# BEDDED STEEL BEAMS

---

Steel beams or RSJ's are normally used in mid to long span situations to support heavy structural elements such as podium decks or load bearing walls. The waterproofing of steel beams is usually restricted to sealing the ends, where they may be embedded or supported within basement retaining walls or upon structural piers or recessed pad stones, thereby potentially "piercing" the internal basement waterproofing system.

The internal waterproofing of the recessed "pocket" upon which the beam end will rest can be achieved using Type A cementitious barrier products such as NB1 Grey Repair Mortar Plus or KB Flex 200 will act to reduce the likelihood of leakage in this particular area. The installation of the specially pre-formed rubber "boot" within the pocket will ensure watertight barrier around the beam and it will provide a ready flange around the pocket edge to which the Type C internal cavity drainage membrane can be sealed, so providing continuity of the internal waterproofing system around the beam.

## Associated Products:

- Delta Joist Boots (Top Hats)
- Koster Repair Mortar Plus
- Koster NB 1
- Delta Cornerstrip
- Koster Bitumen Primer

---

## DELTA JOIST BOOTS (TOP HATS)

Delta Joist Boots (Top Hats) are manufactured from high performance flexible dpc.

- Suitable for continuous waterproofing
- Suitable for new build and refurbishments
- Easy to install
- Available to suit any size
- Fast delivery

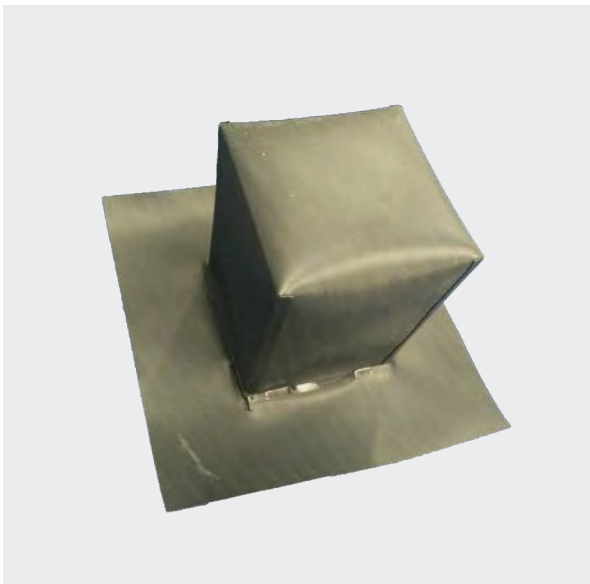

# BEDDED STEEL BEAMS

---



## DELTA CORNERSTRIP

Delta Corner Strip is a waterproof, firm and lasting single-sided sealing tape applied to seal wall to floor junctions and internal penetrations through the Delta membrane system. Delta Corner Strip creates a vapour seal making it an ideal solution for patch repairs and detailing around service penetrations (150mm x 20 m).

- Used for abutting joints
- For repairs or where membranes have been cut to enable them to overlap
- Excellent for sealing and repair
- Creates a vapour seal
- Suitable for sealing service penetrations
- Suitable for fixing plugs to membranes

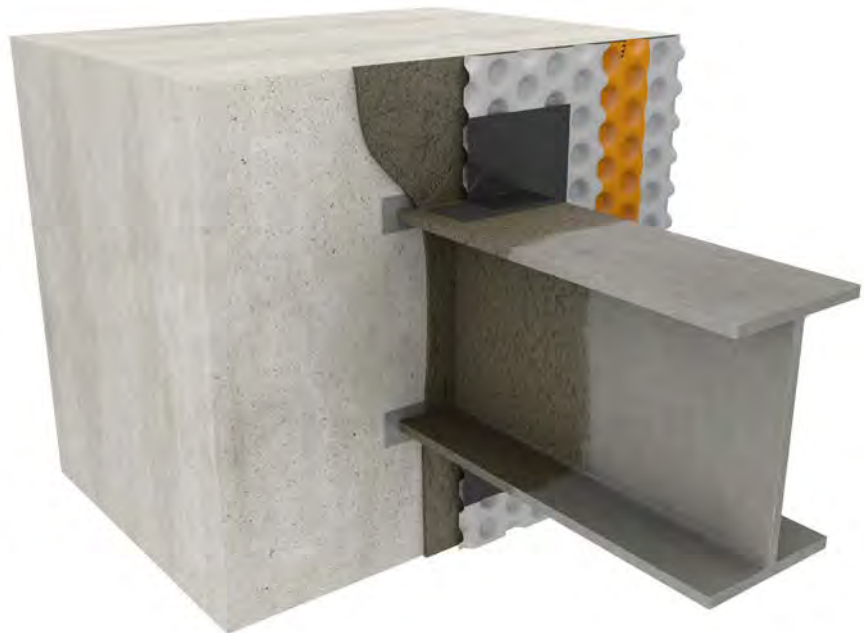
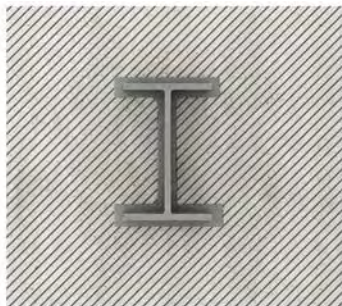



# ACTIVE LEAKS

Sources of external water such as a high or rising water table, river, extreme weather, tidal changes, poorly drained soil, defective drains can all result in water penetration of a structure at below ground level.

This penetrating water may have enough pressure and strength to ingress a structure, even one which is presumed to have been adequately waterproofed. Basements and other below ground structures can leak both during and after construction. Any construction below ground will always be subject to groundwater. Groundwater will try and will seep through cracks and joints in all construction. Joints (from movement to floor/wall junctions) will always require attention when waterproofing and these are common pitfalls in project fails.

Remedial work to active leaks in construction, which is exposed, are relatively easy to find and fix. If the construction is not exposed and finishing's are in place, these leaks are difficult to find but not impossible. Use of a thermal imaging cameras/borescopes/moisture meters or visual inspections are usually enough to locate these leaks.

## Associated Products:

- Koster 2 in 1
- Koster in 7
- Koster Waterstop
- Koster KD Blitz
- Koster Repair Mortar Plus
- Koster KB Fix 5



## KOSTER 2 IN 1

Koster 2 IN 1 stops active leaks and seals cracks and construction joints permanently and elastically. It can be injected in dry and wet cracks. The material can also be used for filling of voids. 2 IN 1 is a water reactive elastic PU-injection resin for single and two stage injection of dry and water bearing cracks and joints.

When Koster 2 IN 1 resin comes into contact with water, it reacts to form a highly elastic foam. When 2 IN 1 resin is injected under dry conditions, it reacts to form a solid body elastic resin. Koster 2 IN 1 remains permanently elastic after reacting.

- Used in conjunction with Type A & Type B Waterproofing systems
- Stops active leaks and seals crack and construction joints permanently
- Easy application
- Seamless application
- Fast curing
- Applied on dry or water bearing cracks and joints

# ACTIVE LEAKS

---



## KOSTER IN 7

Koster IN 7 is a single component viscoplastic PU-injection foam for waterproofing of cracks in concrete and masonry. It stops leakages even under pressurized water. IN 7 is applied in a single step without necessity of subsequent injection with a solid body resin.

- Permanently seals and bridges cracks, joints and restores structural integrity
- Solvent-free
- Resistant to hydrolysis.
- Stops leakages even under pressurized water
- Easy, Seamless application
- Suitable for new construction and repair on existing structures

## KOSTER KD BLITZ

Koster KD 2 Blitz powder instantly stops active leaks (from dripping to flowing), whilst offering versatility in both non-pressurized and pressurized waterproofing from positive and negative side substrates. Koster KD 2 Blitz powder is a unique component of the Koster KD System (KD 1 Base, KD 2 Blitz powder and KD 3 Sealer) which can be used either as part of the KD System or standalone in sealing and/or closing cracks prior to the use of injection resins.

- Fast Curing Time
- Highly Reactive
- Suitable for waterproofing positive and negative side of substrates
- Suitable for active leaks (pressurized and non-pressurized)
- Suitable for sealing and closing cracks prior to use of injection resins
- Instantly stops active leaks



# TABLE

Table 1

	Waterstop	KD System	KD Blitz	Koster NB 1	DPC	Joint Tape 20	Resin Injection Systems	2 IN 1
Active Leak	*	*	*				*	*
Capillary break				*	*			
Cold Joint				*		*		
				With SB Bonding Emulsion				
Construction Joint							*(if Leaking)	*(if Leaking)
Contraction Joint						*	*(if Leaking)	
Crack Repair								
Dummy Joint								
Expansion Joint						*	*(if Leaking)	
Floor/Wall Junction						*		
Honeycombed Concrete							*(if Leaking)	
Kicker				*		*		
Movement Joint						*	*(if Leaking)	
Pressed Joint						*	*(if Leaking)	
Reveals					*			
Service Penetrations								
Settlement Joint							*(if Leaking)	*(if Leaking)
Unplanned movement joint						*	*(if Leaking)	*(if Leaking)



# TABLE

Table 2

	FSV	FSH	PU 907	Repair Mortar Plus	Betamour Multi A	KB Fix 5	Puddle Flange	KB Flex 200	Quellband
Active Leak									
Capillary break									
Cold Joint									
Construction Joint	*	*	*	*					*
Contraction Joint	*	*	*						
Crack Repair				*	*	*			
Dummy Joint									
Expansion Joint	*	*	*						
Floor/Wall Junction				*					
Honeycombed Concrete				*	*	*			
Kicker									
Movement Joint	*	*	*						
Pressed Joint	*	*	*						
Reveals									
Service Penetrations						*	*	*	
Settlement Joint		*	*	*		*			
Unplanned movement joint		*	*						

# TECHNICAL DRAWINGS

To view our full range of technical drawings, please visit our website on [www.deltamembranes.com/technical-categories/technical-drawings/](http://www.deltamembranes.com/technical-categories/technical-drawings/) or contact our technical department on 01992 523 523.

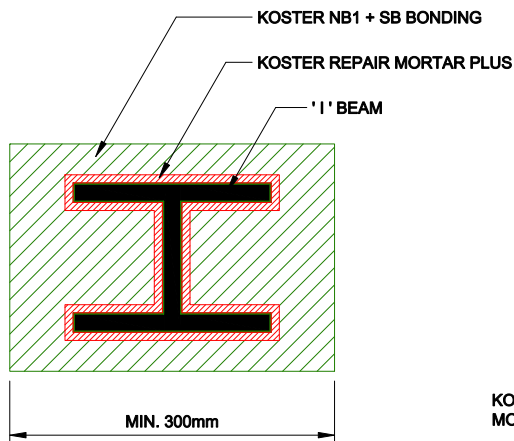

**WATERPROOFING TO EXISTING STEEL BEAM END  
KOSTER DETAIL ONLY**

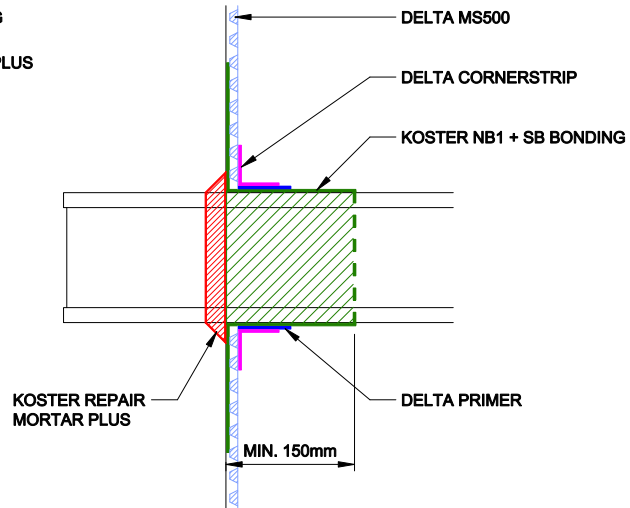

**KOSTER + DELTA MS DETAIL**

## CONSTRUCTION JOINTS - KOSTER QUELLBAND

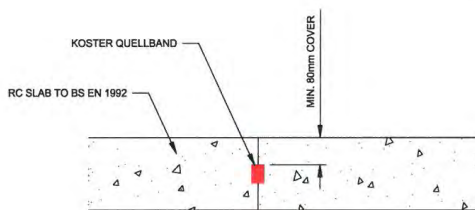

**NEW SLAB CONSTRUCTION JOINT**

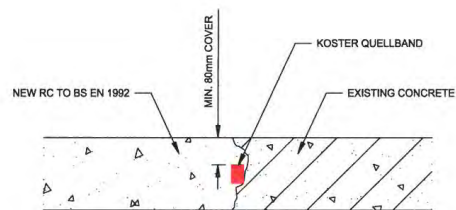

**NEW TO EXISTING CONSTRUCTION JOINT**

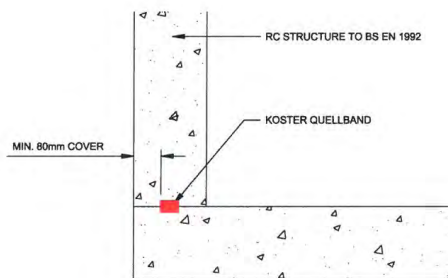

**KICKERLESS CONSTRUCTION**

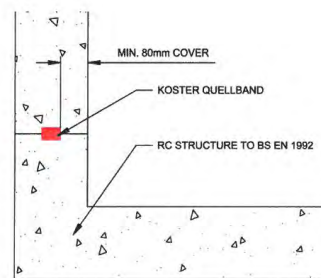

**KICKER CONSTRUCTION**

# TECHNICAL DRAWINGS

## DELTA MS500 / DELTA BOOT TO STEEL BEAM END

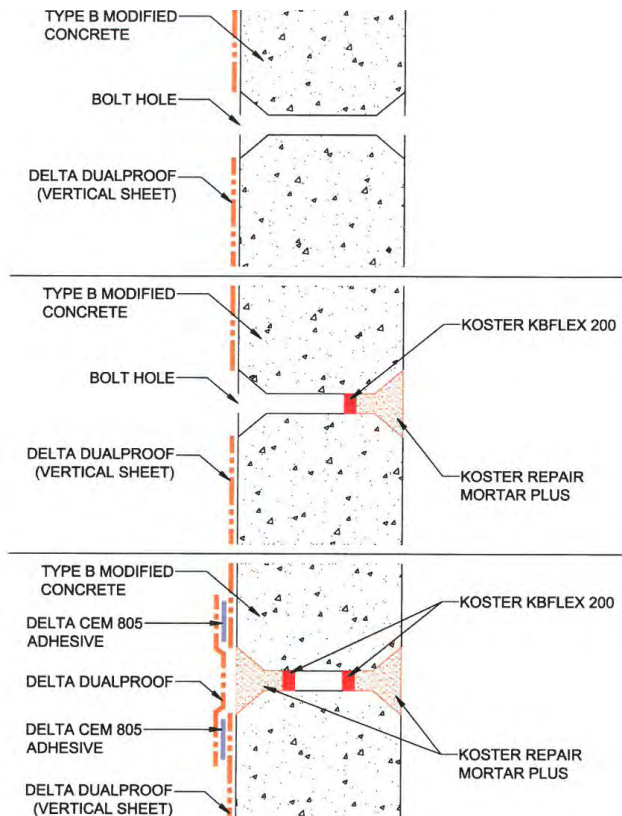
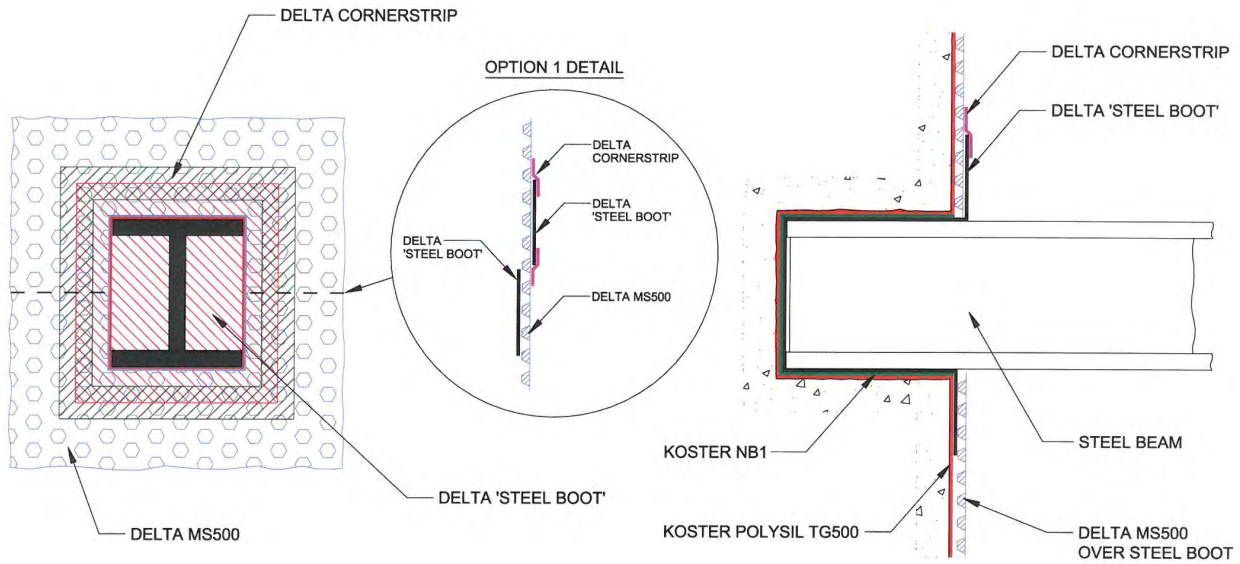



# TECHNICAL DRAWINGS

## EXPANSION / MOVEMENT JOINT DETAILING

JOINT SEALANT - HEIGHT: WIDTH RATIO 2:1

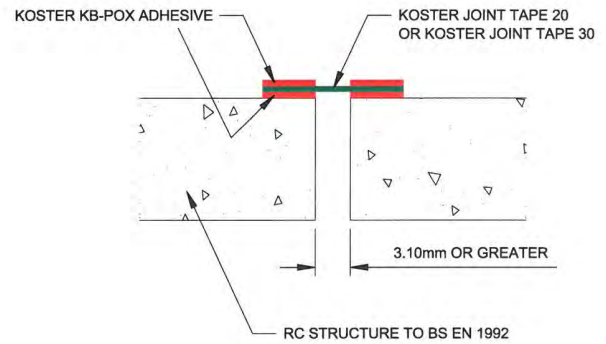
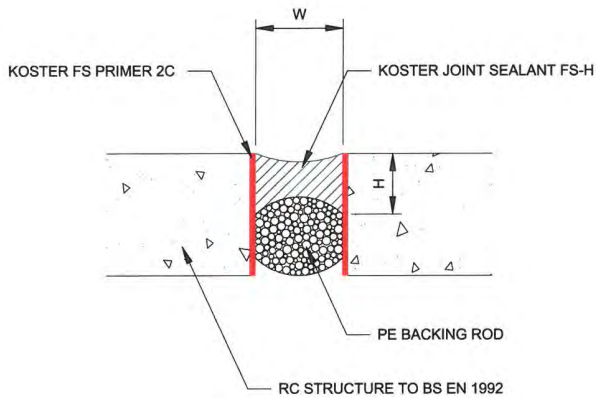

## SERVICE PENETRATIONS PLUS CABLE DUCT SEALING

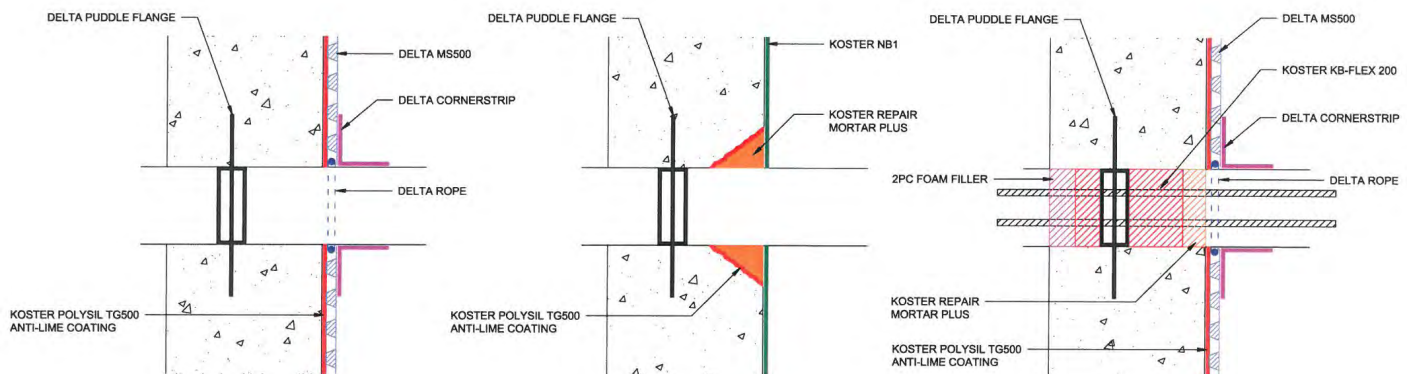

# TECHNICAL DRAWINGS

## SERVICE PENETRATIONS - DELTA DUAL PROOF

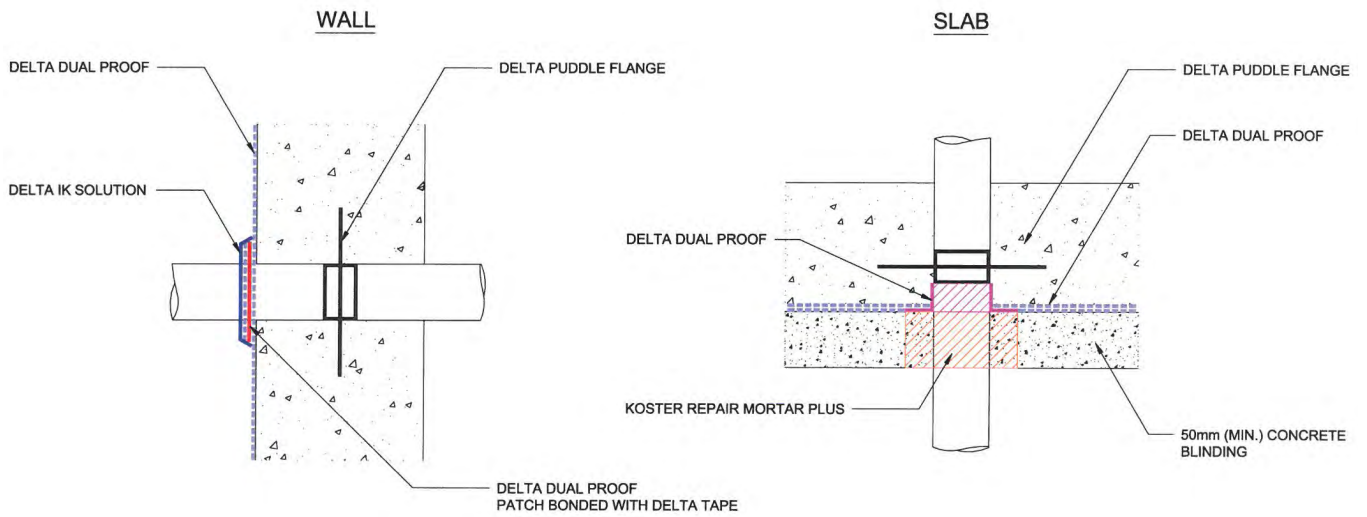

## DETAILING TO DRY PACK - FOR DELTA MS CAVITY DRAIN SYSTEM

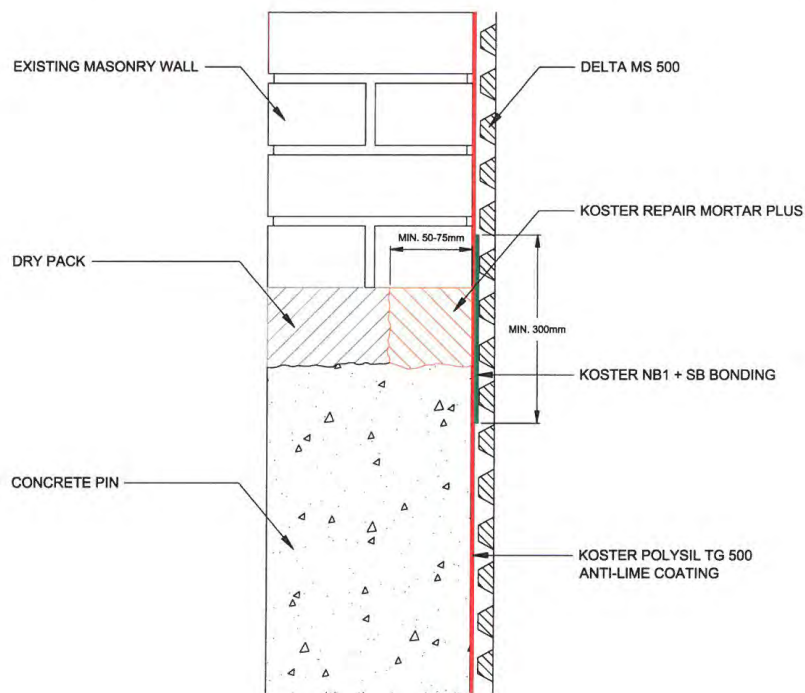

# TECHNICAL DRAWINGS

## DELTA MS500 - ISOLATING WALL / FIRECHECK

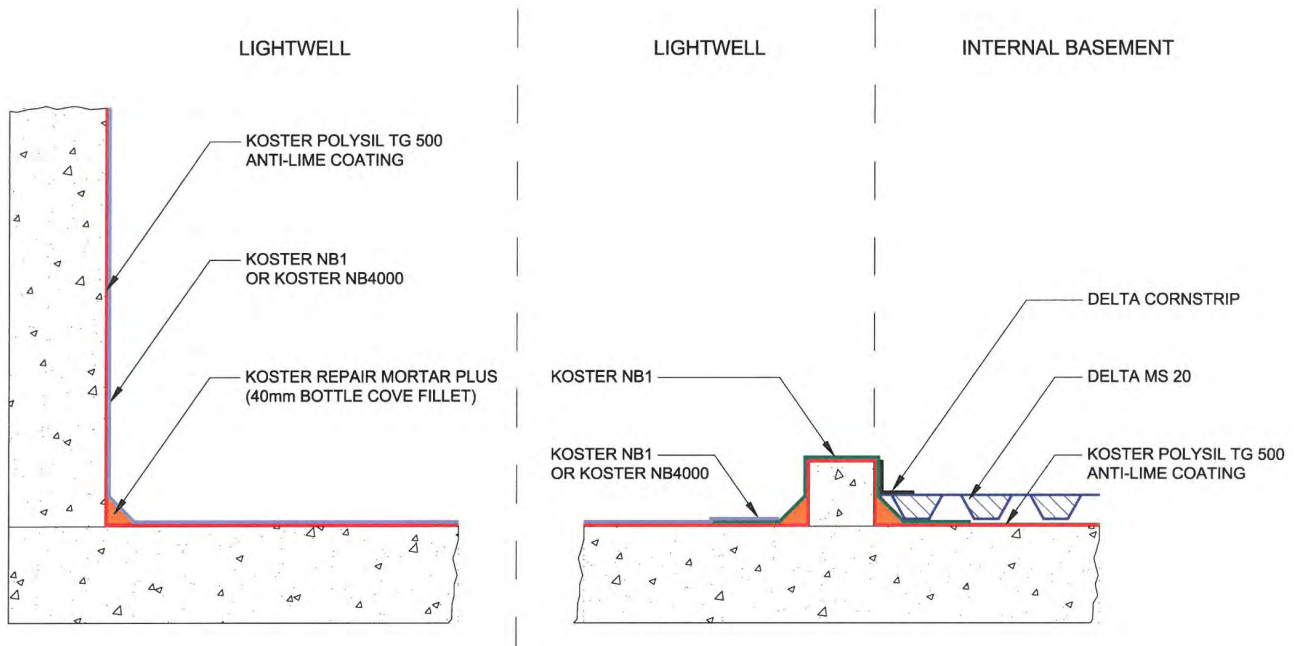
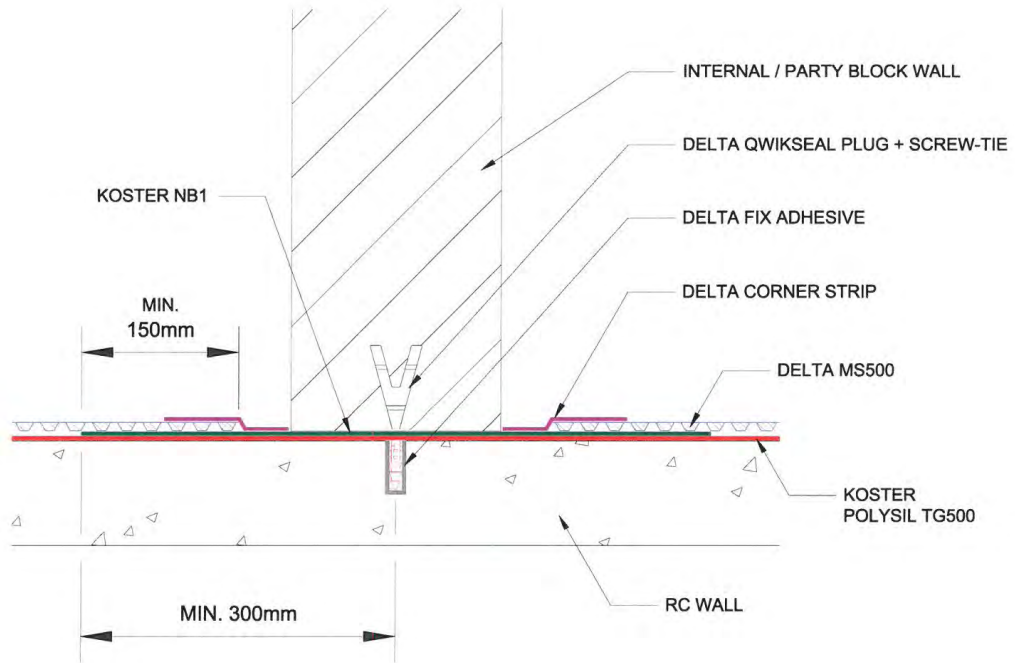



# TECHNICAL DRAWINGS

THIS DETAIL IS DESIGNED ONLY TO SHOW THE WATERPROOFING DETAIL. ANY STRUCTURAL IMPLICATION SHOULD BE CHECKED WITH A STRUCTURAL ENGINEER

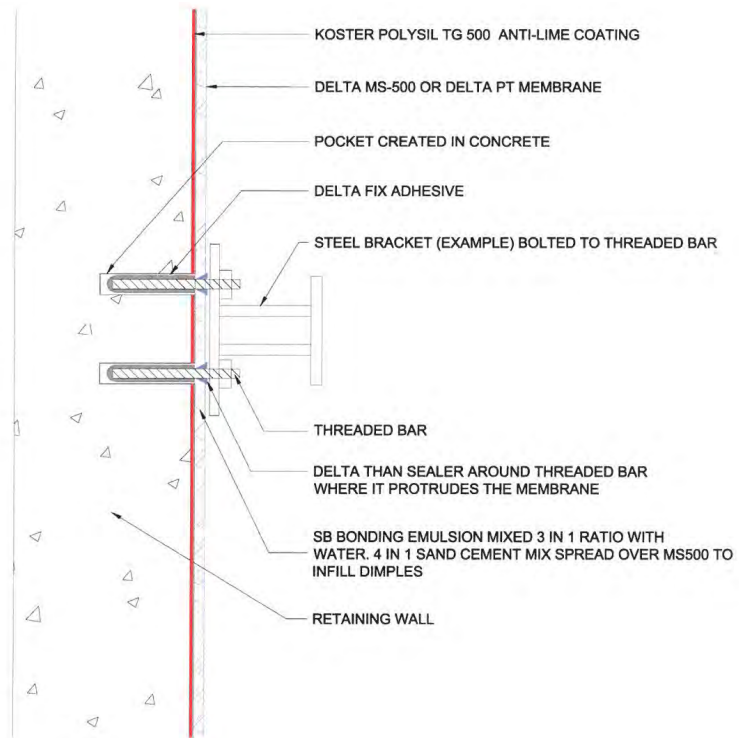

## WATERPROOFING DETAIL BOLTED COLUMN TO FLOOR

