

Centerline

CLPL planter

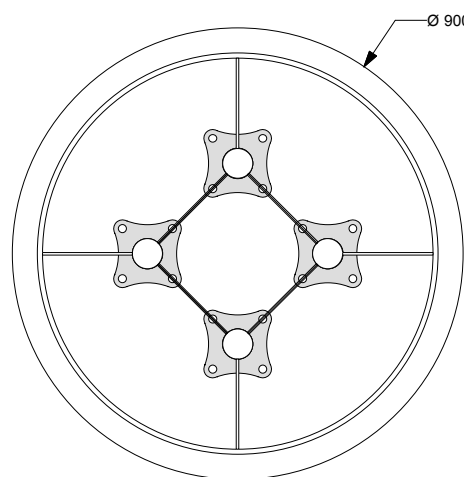

INSTALLATION METHODS

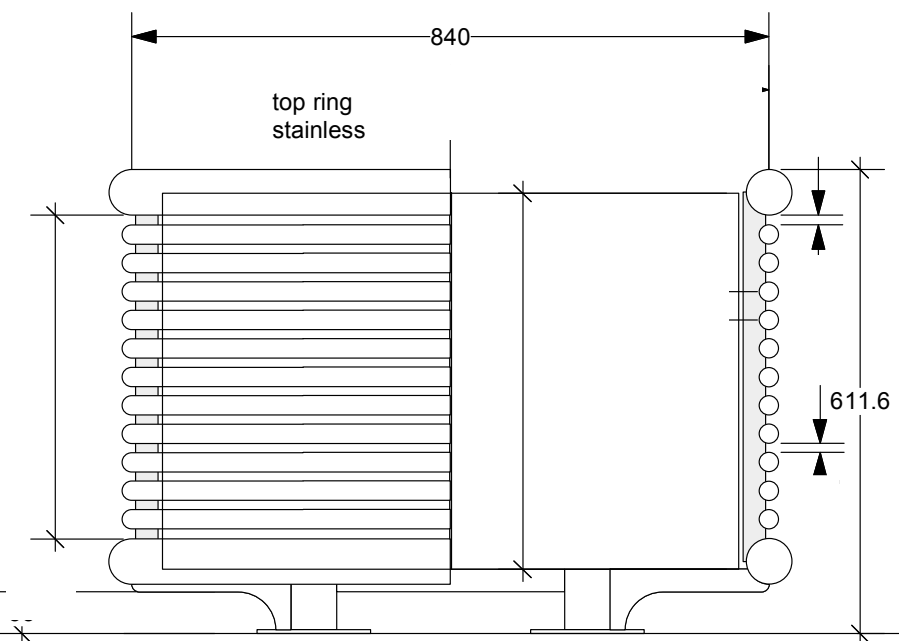
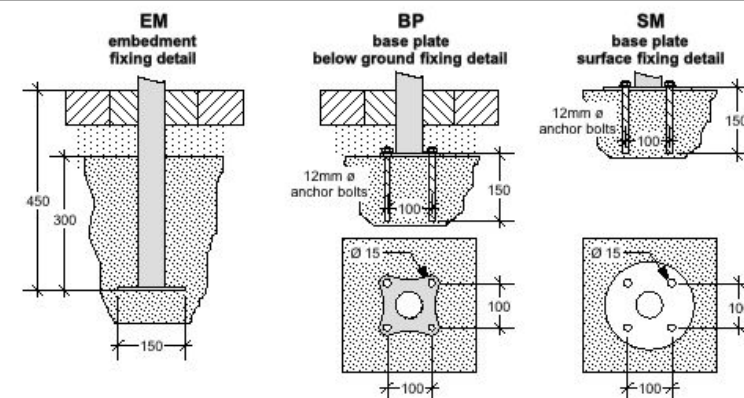

DIMENSIONS

LWH As requested – example above

EXTRAS

CP Composite finish

FINISH CODES

PC Powder coating on galvanised steel

SS 316 stainless steel 320 grit

BD Bespoke dimensions available

INSTALLATION CODES

EM Embedment fixing

BP Base plate below ground fixing

SM Base plate surface fixing