

Shoreline

SLPL planter

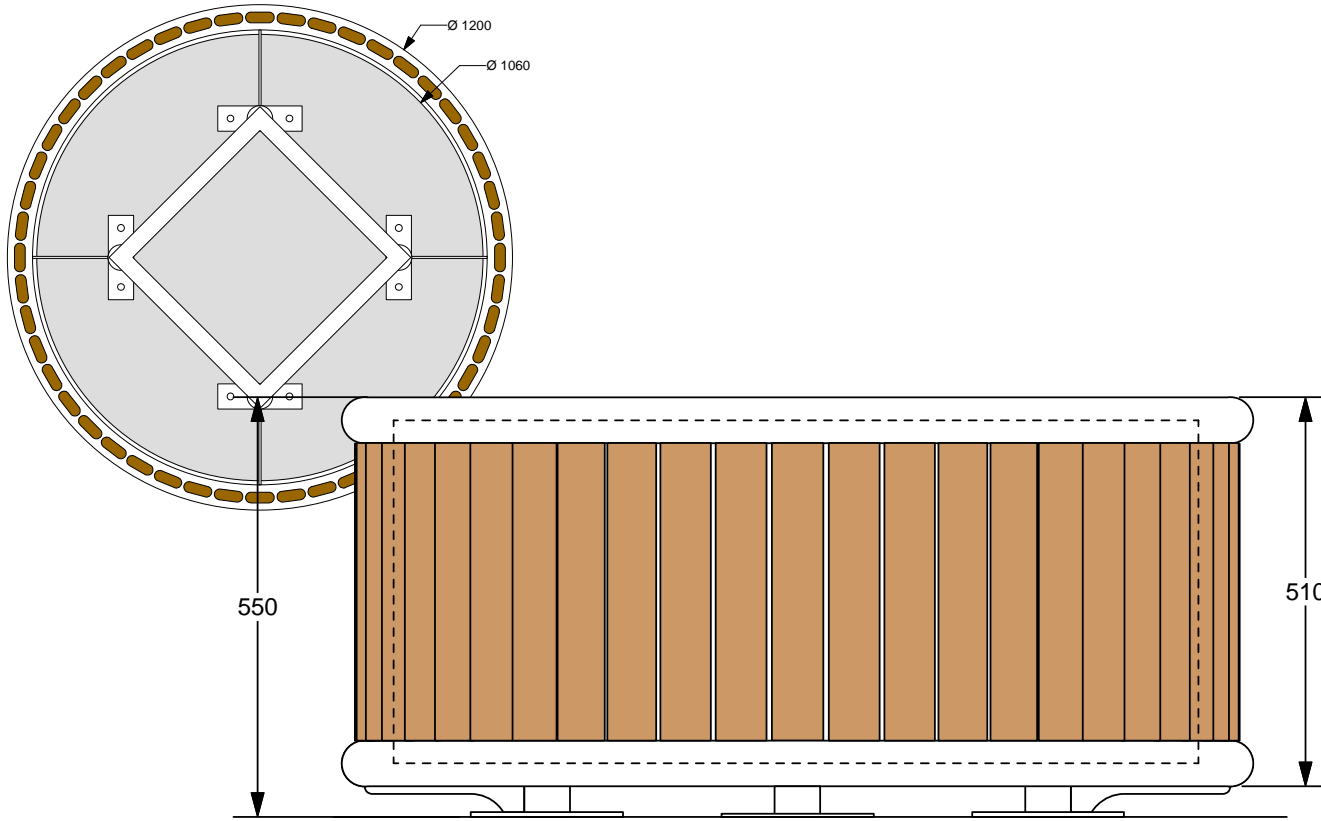

INSTALLATION METHODS

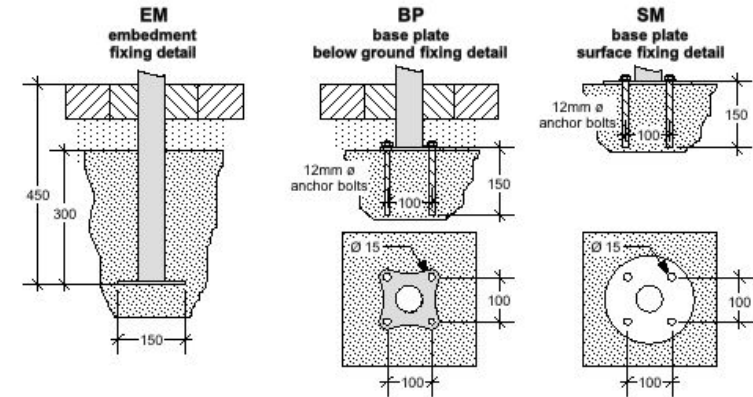

DIMENSIONS

LWH	Example above
-----	---------------

EXTRAS

PL	Plaque, Drainage system
----	-------------------------

FINISH CODES

IR	Iroko FCS approved
DF	Douglas Fir FCS approved
BD	Bespoke dimensions available

INSTALLATION CODES

EM	Embedment fixing
BP	Base plate below ground fixing
SM	Base plate surface fixing