



Fire Rated Options are available on certain ranges offering fire protection for up to two hours!



Strict Quality Management systems ensure that we always deliver high quality products efficiently.



Our Panels Comply with all Gas Safe Regulations for added safety, security and reliability.



Our acoustic panels are tested up to RW 63 db.



Thermally insulated and airsealed options available, complying to building regulations parts L1 & L2.



All of our panels are 100% recyclable.



Our office and factory are both based in the UK.



Visit our online shop for the easiest way to download technical information, see video fitting instructions and buy online.

THE ACCESS PANEL
COMPANY LTD



*The Old Water Works, Winterton Road,
Scunthorpe, North Lincolnshire,
DN15 0BA
01724 853090
sales@accesspanels.co.uk*

THE ACCESS PANEL
COMPANY LTD



The Access Panel Handbook 2012

www.accesspanels.co.uk





Access Panel Innovators

Welcome to the second edition of the Access Panel Handbook. This 2012 edition contains many of the most creative solutions available in the access panel world bringing great looking solutions into reach of every budget. Last year we shook up the trade with our latest designs making the panels easier to fit, simpler to specify and improving performance. This year we are branding the range as 'The Classic Brand' and developing the brand with advanced fire ratings, gas safe products, cost savings and improved delivery lead times.

But its not just the product we have been working on, our design team is now four strong headed up by new man Paul Dannatt who brings a wealth of experience from the cutting edge of 3D modelling. Paul's influence can be seen in the increasingly technical CAD drawings and PDF downloads available on the website.

The site itself is being re-launched with video instruction, factory tours, fitting hints and tips and an on-line shop including trade only areas with prices for the contractor. Sign up now and get a host of free goodies including a FREE access panel whilst stocks last!

Riser doors have been a big focus this year with a novel fire rated design which opens to 180°. This moves the panel toward a steel door type product bringing with it all the strength associated with a steel door set. Approved by the M.O.D this door has gone through rigorous testing and is definitely fit for purpose.

We see it as our job to push the boundaries of access panel design, adapting to the economic environment by delivering cost savings in both fitting time, value and performance. I hope you will agree this is the most easy to read, informative catalogue we have produced, delivering high quality panels to all our customers irrespective of budget.

Thank you for your continued support and enjoy our latest catalogue

Simon & the team



Index

- Page 3 SLIK System
- Page 5 Premium Range
- Page 7 Premium Fire Rated
- Page 9 Premium Accoustic
- Page 11 Premium Double Door (Wall)
- Page 13 Premium Double Door (Ceiling)
- Page 15 Premium Plasterboard
- Page 17 Slimline Plasterboard
- Page 19 Contract Range
- Page 21 Value Range
- Page 23 Plastic Panel
- Page 25 Loft Hatch
- Page 27 Tile Door
- Page 29 Lift Off Tile Door
- Page 31 Alpro Tile Kit
- Page 33 Round Access Panel
- Page 35 Exposed Grid Panel
- Page 37 Air Gap
- Page 39 Roof Hatch
- Page 41 Lock Options
- Page 43 The Factory & Fire Test
- Page 45 Project Showcase



A revolution in access panel appearance

The major advantage of the Slik system is appearance. Missing white caps spoil the architects design and are the bane of the industry calling attention to a panel that is supposed to be inconspicuous. If you want to fit the best looking panel on the market insist on the Slik system.

The Spring Loaded Invisible Keyhole, Slik system, replaces the plastic cap that normally covers the keyhole and which is constantly missing. Our patented invention of the Slik system is one of the most visually obvious differences between us and our competitors.

Also enabling remote operation with a long handled pole the Slik system means there is no need for steps to open the panel from ground level. This is especially relevant for loft hatch type operations where a ladder is then pulled down to access a loft space.

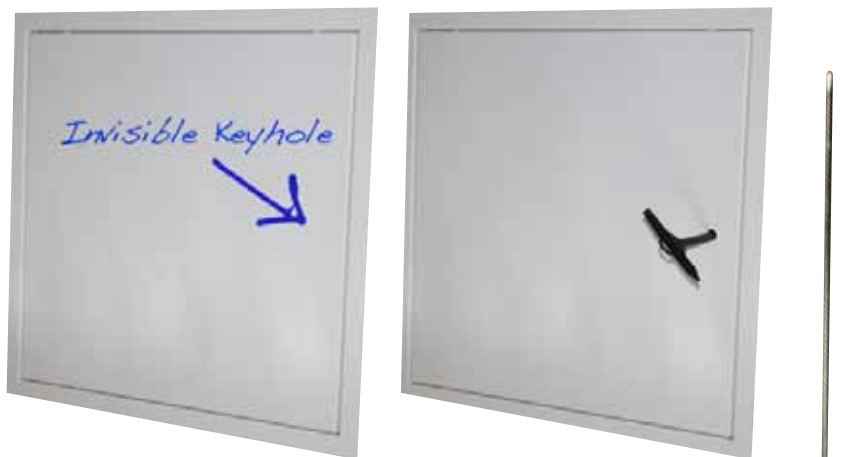

*Open from the ground
with the Long Key
option*



The Ultimate Access Panel

Coming in various design types to suit your size and application the Premium range comes with the Slik System as standard. Working into walls and ceilings as single or double door configurations we have a solution to suit your application or opening. The doors can be specified to acoustic and insulated ratings with and without fire ratings.

'Classic Brand' Premium Access Panel Specification



- Manufactured from 1.2mm 'Zintec' coated mild steel
- Finished in white polyester powder coat RAL 9010 20% Gloss
- Full length hinge or pivot hinge to long edge unless requested otherwise
- Budget lock operated with square drive 'T' key with Slik System invisible keyhole as standard or touch catch operation with safety chains for ceilings or high security sealed lock options
- 25 mm Picture Frame surround or Simulated Bead Frame for tape & jointing on site
- Non Fire rated/Fire Rated/Acoustic Options
- Single and Double Door combinations

Sizes from stock (mm)

150 x 150	200 x 200	300 x 300	450 x 450	550 x 550
600 x 300	600 x 600	900 x 550	900 x 600	900 x 900
1200 x 550	1200 x 600			

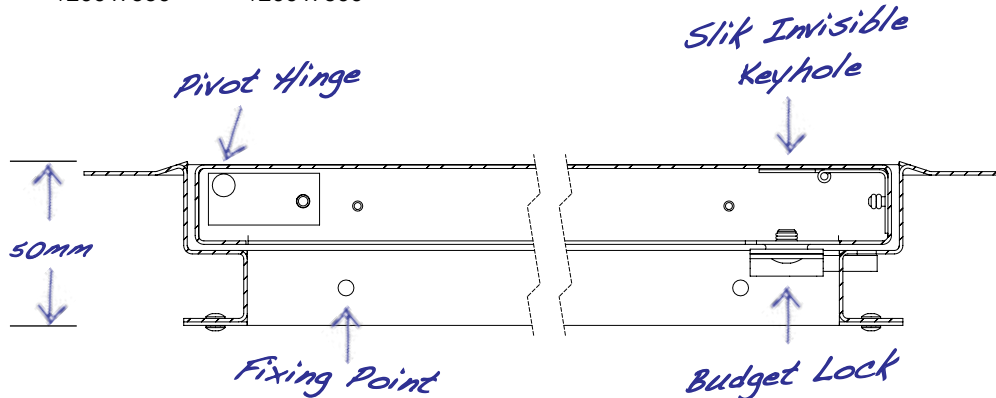

"The Access Panel Company Ltd has been our supplier of choice for access panels for the past six years which is a reflection of the service they are able to provide"



Fire Rated for Walls & Ceilings

Starting life as a standard Premium range panel the fire rated variety are tested to British and European standards with only minor design variations that enable us to offer fire ratings up to two hours without the panel becoming heavy and difficult to fit.

This lightweight fire rated solution is easy and quick to fit and is fitted with the Slik system as standard. Tested to EN standards into ceilings as large double door formats we can offer a variety of insulation ratings which prevent heat build up in service voids above your ceiling.

'Classic Brand' Premium Fire Panel Specification



- Manufactured from 1.2mm 'Zintec' coated mild steel
- Finished in white polyester powder coat RAL 9010 20% Gloss
- Full length hinge or pivot hinge to long edge unless requested otherwise
- Budget lock operated with square drive 'T' key with Slik System invisible keyhole as standard or touch catch operation with safety chains for ceilings or high security sealed lock options
- 25 mm Picture Frame surround or Simulated Bead Frame for tape & jointing on site
- Fire Rated from 30 minutes to 2 hours
- Single and Double Door combinations

Stock Sizes (mm)

150 x 150	200 x 200	300 x 300	450 x 450	550 x 550
600 x 300	600 x 600	900 x 550	900 x 600	900 x 900
1200 x 550	1200 x 600			

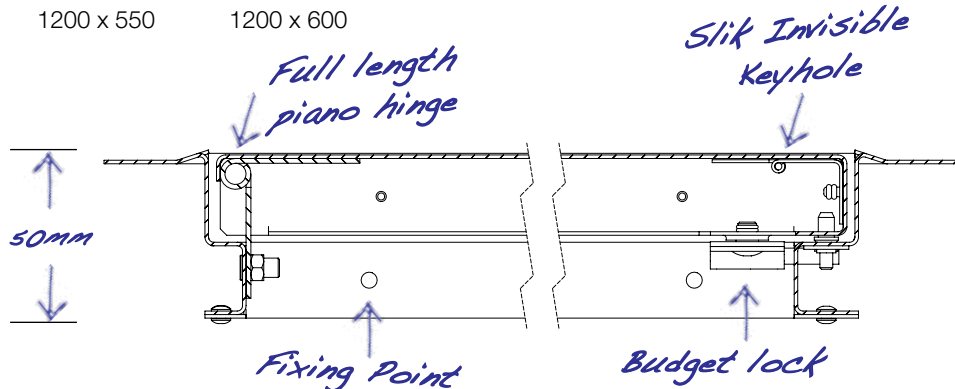

“We would like to express our thanks and appreciation for all of the help you have given us. We would also like to add that we will strongly be recommending your company and services in future.”



Sssshhhh!

This premium panel designed for use where there is an acoustic requirement. Using a variety of sound deadening materials in various combinations we have tested panels to a maximum reduction of 63 dB Rw. Testing was carried out under laboratory conditions to BS EN ISO 140-3: 1995 by an independent test centre.

'Classic Brand' Premium Acoustic Panel Specification



- Manufactured from 1.2mm 'Zintec' coated mild steel
- Finished in white polyester powder coat RAL 9010 20% Gloss
- Full length hinge or pivot hinge to long edge unless requested otherwise
- Budget lock operated with square drive 'T' key with Slik System invisible keyhole as standard or touch catch operation with safety chains for ceilings or high security sealed lock options
- 25 mm Picture Frame surround or Simulated Bead Frame for tape & jointing on site
- Acoustic material to suit applications
- Fire options available

Standard Sizes (mm)

150 x 150	200 x 200	300 x 300	450 x 450	550 x 550
600 x 300	600 x 600	900 x 550	900 x 600	900 x 900
1200 x 550	1200 x 600			

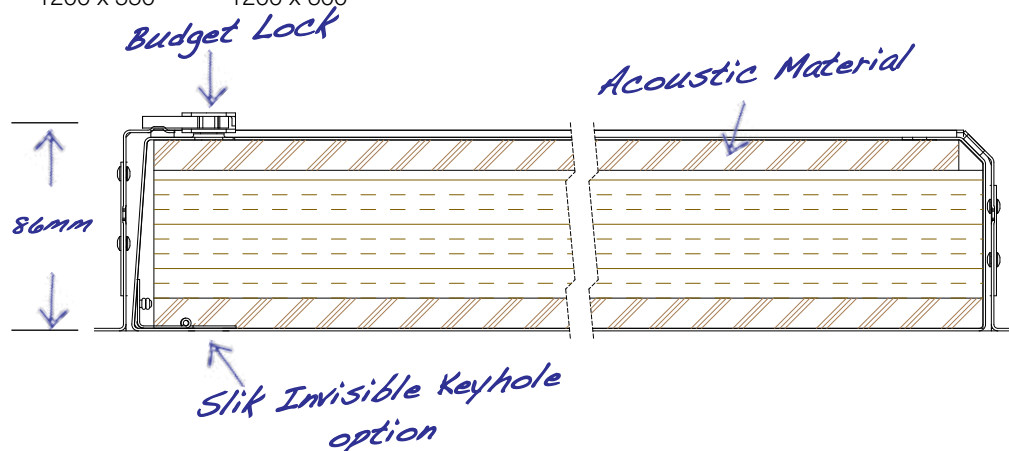

“As a designer it makes my life so much easier to have CAD Drawings tailored to my project. I can also be confident that the solution will work in practice.”



Premium Double
Door Panel
Fire, Acoustic & Air Sealed

Fire Rated Riser Doors

We have a combination of door styles to suit your situation. From heavily insulated to 180 degree opening, the doors are available fire rated up to two hours.

Tested to over 2m high and 1.6m wide these door sets are more akin to steel access door sets than access panels and can accommodate access to the majority of M&E plant maintenance needs.

'Classic Brand' Premium Double Door Wall Panel Specification

- Manufactured from 1.2mm 'Zintec' coated mild steel
- Finished in white polyester powder coat RAL 9010 20% Gloss
- Budget lock operated with square drive 'T' key with Slik System invisible keyhole as standard or touch catch operation with high security sealed lock options
- 25 mm Picture Frame surround or Simulated Bead Frame for tape & jointing on site
- Double door panel has no central post with the doors closing one onto the other.
- The second door is unlocked by concealed locks visible when first door is open
- Fire Rating for integrity, insulation or both available



Standard Sizes (mm)

1200 x 1200 1800 x 1200 2000 x 1200

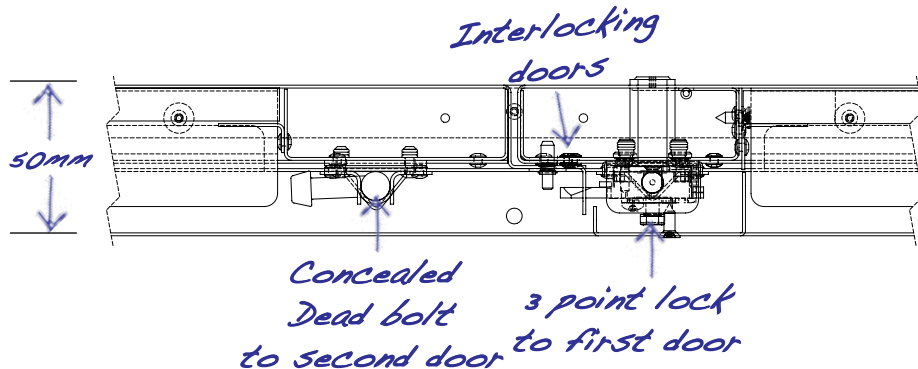

Doors open 180°



Doors open 180°



"...the client's architects are extremely happy with the access doors, especially the tiled one. It's the best they have come across and have asked for your contact details for the future."



*Lightweight & easy
to use*

This version of our Premium 'Classic Brand' panel is for large ceiling openings. The first closing doors locks are concealed by the closing of the second door whose locks are accessed via our invisible keyhole 'Slik' system. A discrete solution that can also be offered in a lightweight fire rated version. Weight is an important consideration when specifying ceiling access panels. The price of fitting and reinforcing a ceiling structure may outweigh any initial price differential, our panels are the lightest solutions available.

Ceiling doors are available in any combination of bomb bay doors, hinged opposing edges, short edges or long edges or even long runs with panels hinged alongside each other to create large unobstructed openings, the longest of which to date has been 28 metres.

'Classic Brand' Premium Double Door Ceiling Panel Specification

- Manufactured from 1.2mm 'Zintec' coated mild steel
- Finished in white polyester powder coat RAL 9010 20% Gloss
- Budget lock operated with square drive 'T' key with Slik System invisible keyhole as standard or touch catch operation with safety chains or high security sealed lock options
- 25 mm Picture Frame surround or Simulated Bead Frame for tape & jointing on site
- Double door panel has no central post with the doors closing one onto the other.
- The second door is unlocked by concealed locks only visible when first door is open
- Fire Rating for integrity, insulation or both



Standard Sizes (mm)

1200 x 1200 1800 x 1200

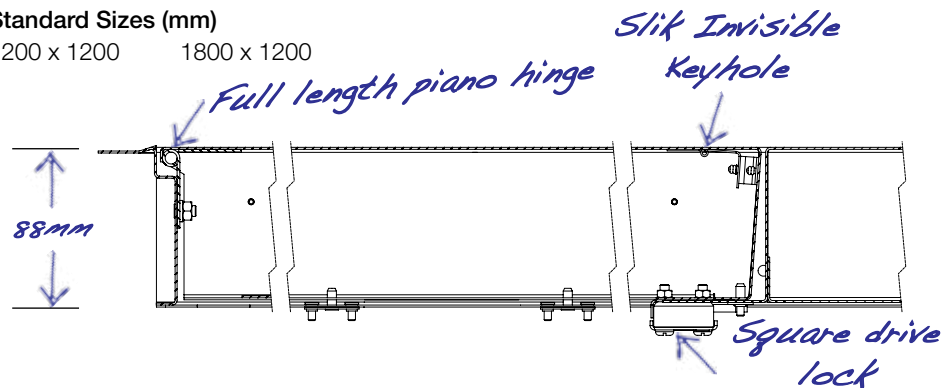

“Time and time again, The Access Panel Company get it right! The right product, the right price and always right on time. We have stopped calling other manufacturers as we feel there is no need. We recommend this company for all your panel and riser door needs”



*For a complete
Plaster finish*

Ideal for continuing a specialist plaster finish effect across the ceiling, but as with any door skimmed with plaster can be delicate. Especially popular with architects, this deep door tray gives the door stability and minimises potential cracking to the door face. Where our panel wins out over the competition is the lock detail; available with a push catch, high security radial pin tumbler lock or a budget lock with the patented 'Slik Invisible Keyhole', the panel can almost disappear into the ceiling surface. With any plasterboard faced door the lock area is subject to the most use and therefore the place where any damage to the surface will occur first. With our panel in each of the lock options the lock area around the lock is imperceptibly reinforced and protected to prevent damage.

'Classic Brand' Premium Plasterboard Panel Specification



- Manufactured from 1.2 & 0.9mm 'Zintec' coated Mild Steel.
- Finished with white polyester powder coat RAL 9010 20% Gloss
- Plasterboard factory fitted into door face with formed edge bead surround,
- Simulated bead edge to frame for tape & joining on site.
- Budget lock operated with square drive 'T' key with Slik System invisible keyhole as standard or touch catch operation with safety chains or high security sealed lock options
- Fire Ratings

Standard Sizes (mm)

300 x 300 450 x 450 600 x 600 900 x 600 1200 x 600

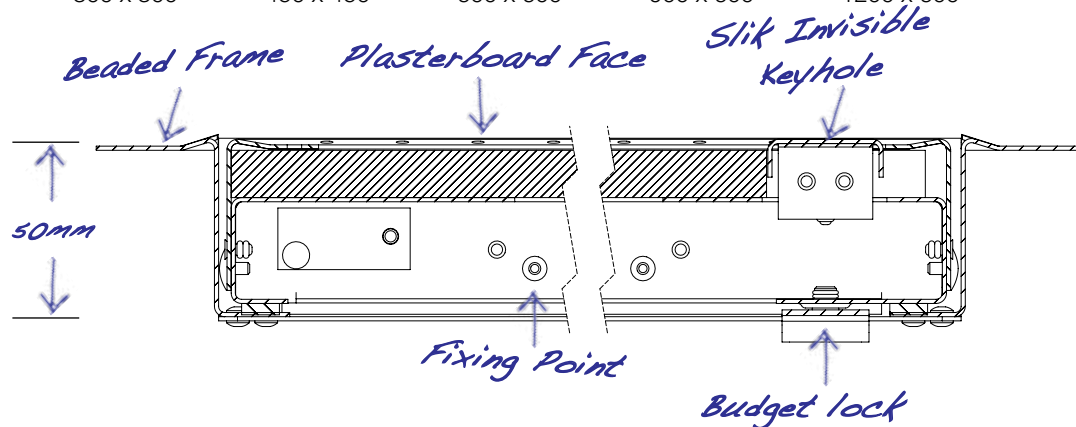

"I wish I'd known about your company years ago, I would have saved a fortune."



For walls & Ceilings

Designed to work into walls and ceilings whilst maintaining the narrow door to frame gap this plasterboard faced panel is the narrowest plasterboard faced panel on the market. The door tray encapsulates the plasterboard exactly and depending on the lock mechanism chosen the frame is only a few millimetres thicker. As with the Premium Plasterboard faced panel we win over the competition by the lock detail. Available with a push catch, high security radial pin tumbler lock or a budget lock with the patented 'Slik Invisible Keyhole' the panel can almost disappear into the ceiling surface. With any plasterboard faced door the lock area is subject to the most use and therefore the place where any damage to the surface will occur first. With our panel in each of the lock options the lock area is imperceptibly reinforced and protected to prevent damage.

'Classic Brand' Slimline Plasterboard Panel Specification

- Manufactured from 1.2 & 0.9mm 'Zintec' coated Mild Steel.
- Finished with white polyester powder coat RAL 9010 20% Gloss
- Plasterboard factory fitted into door face with formed edge bead surround,
- Simulated bead edge to frame for tape & joining on site.
- 'Slik' invisible keyhole concealing square drive lock mechanism.
- Extra thin space saving design.
- Pivot hinge operated.
- Fire Ratings
- Touch catch operation
- High security lock options



Standard Sizes (mm)

200 x 200 300 x 300 450 x 450 600 x 600 900 x 600

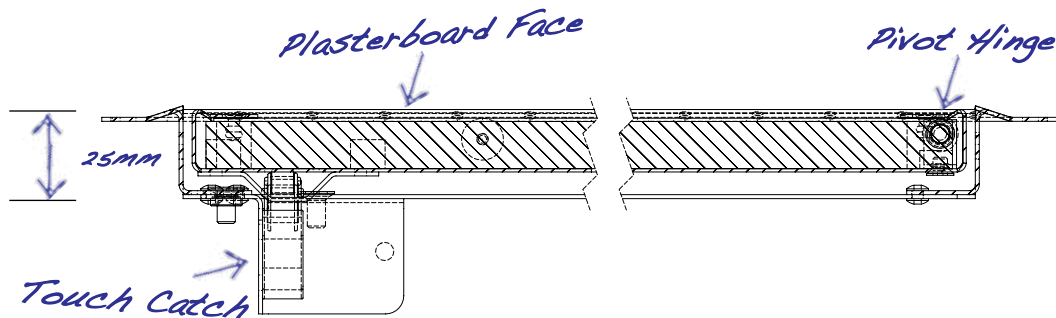

"Thank you for all of the help, after dealing with difficult suppliers it is very refreshing to deal with someone who actually wants to help."



The No.1 Trade Choice

As attractive as the Premium Panel with the Slik option specified this narrow framed panel is easy to fit and forget. A trade favourite the panel is lightweight and fully designed so there are no sharp corners and every fixing point is the right size for the screws your tradesman always carries.

For the specifier, as with all our products, this range is fully supported by NBS and CAD details which our drawing office will provide for your project. We carry hundreds of panels in stock for next day delivery and can also find bespoke sizes to fit your odd shaped holes from our extensive stocks.

'Classic Brand' Contract Panel Specification

- An economical solution to wall & ceiling access where space is at a premium
- Manufactured from 1.2 & 0.9mm 'Zintec' coated mild steel
- Finished in white polyester powder coat RAL 9010 20% Gloss
- Frame depth only encroaches 25mm into the aperture
- Hinged pivot mechanism to long side with removable door
- Budget lock operated with square drive supplied 'T' key
- Other locking methods on request
- 25 mm Picture Frame surround or Simulated Bead Frame for tape & jointing on site
- Slik invisible keyhole option

Stock Sizes (mm)

150 X 150 200 x 200 300 x 300 450 x 450
600 x 600

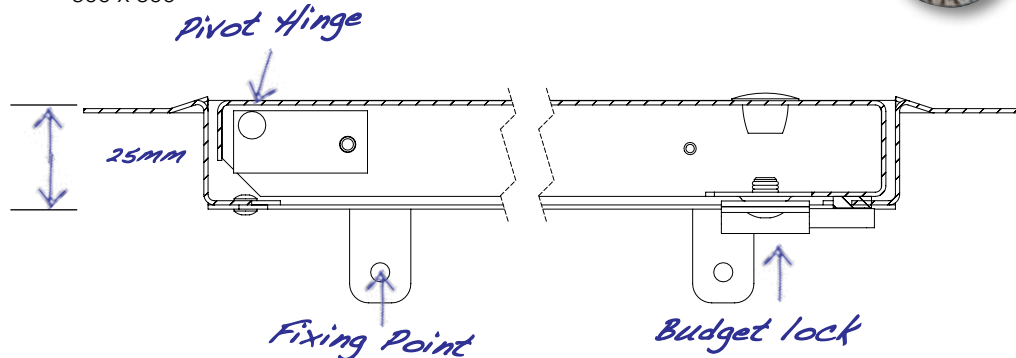

“Your staff perform, they have really pulled out all of the stops to help.”



Fits every budget

This great looking panel is available in both picture frame and beaded frame options with our unique 'twist lock' opening system. The locking mechanism is concealed behind a plastic cap and the panel is locked and unlocked by first removing the cap then inserting a flat head screwdriver to operate the mechanism.

Built to our usual high quality the panel will deliver the finest appearance whilst fitting into the tightest of budgets.

'Classic Brand' Value Panel Specification

- For wall or ceiling access where space is at a premium
- Manufactured from 0.9mm 'Zintec' coated mild steel
- Finished in white polyester powder coat RAL 9010 20% Gloss
- Frame depth only encroaches 18mm into the aperture
- Removable door on pivot screw hinges
- 'Twist Lock' screwdriver operated lock
- 25 mm Picture Frame surround or Simulated Bead Frame for tape & jointing on site



Stock Sizes (mm)

150 X 150 200 x 200 300 x 300 450 x 450 600 x 600

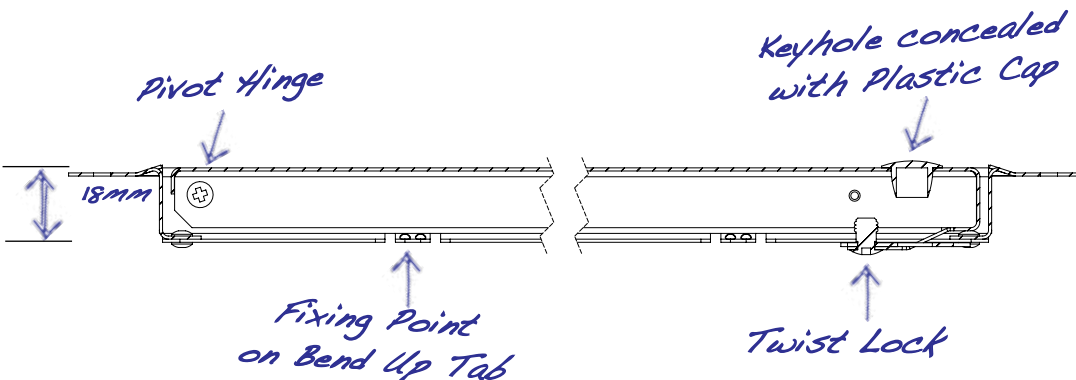

"Our access panel requirements are always solved in one easy phone call."





Easy repair solutions

An economical lightweight panel available in small sizes ideal for access to rodding eyes or as a repair panel when a hole may have been broken out to repair a leak.

Now available in more sizes just install with silicone or no nails allowing the picture frame flange surrounding the panel to cover the cut edge of your hole. The panels are self finished in off white.

'Classic Brand' Plastic Panel Specification

- For an economical access point to concealed services or as a repair panel.
- Manufactured in UV stabilised ABS in white equating to RAL 9010.
- Integrated pivot hinges moulded into the frame and door tray.
- Light weight to be fixed with suitable proprietary building adhesive.
- Snap close hinged removable door.
- 25mm Picture Frame surround.
- Retail box for resale or bulk packed for site use.

Stock Sizes (mm)

160 x 110	150 x 150	230 x 150	200 x 200
300 x 300	350 x 350		

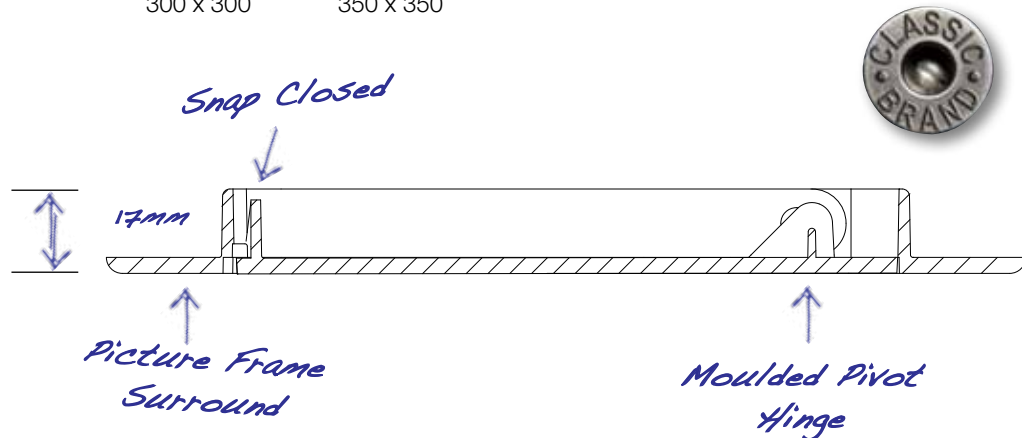

"I have been a customer of The Access Panel Company for 7 years and they provide a great range of products, excellent customer service with a helpful and friendly sales team"



Loft Hatch

Fire, Acoustic & Air Sealed

Options

Complies with Building Regulations

We have a variety of loft hatch solutions to fit every situation. Specify combinations of fire rating, acoustic, air sealed and insulation levels to tailor your loft hatch to your building requirements.

Designed to fit between 600mm centre trusses the Classic Brand Loft Hatch is an attractive alternative to the usual plastic hatch options or timber architrave surrounded solutions.

A badly sealed hatch can lose as much as 6m³ of warm air per hour. Air sealed testing qualifies this hatch as a major eco-friendly contributor to your home.

'Classic Brand' Loft Hatch Specification



- Manufactured from 1.2 & 0.9mm 'Zintec' coated mild steel
- Pivot hinged to short side to allow drop down ladder access
- Finished in textured white polyester powder coat RAL 9010 20% Gloss
- Budget lock operated with square drive 'T' key with Slik System invisible keyhole optional
- High security lock options for communal areas
- 25 mm Picture Frame surround with soft corners
- Air sealed and draught stripped to 0.17m²ph
- Thermal U-value 0.35W/m²K complying with Building Regulations L1
- Fire Rated 60 minutes by Chiltern International Fire

Stock Sizes (mm)

530 x 630

530 x 745mm

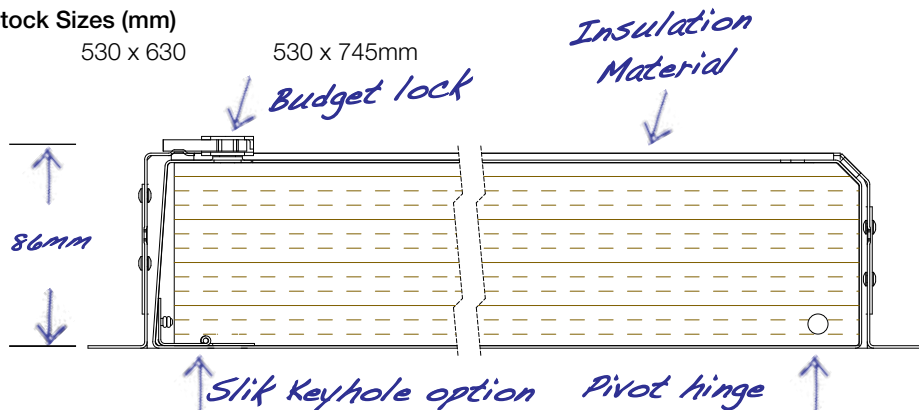

"I have been dealing with The Access Panel Company for a good few years. Their working knowledge, customer service, prices and turnaround times are second to none. I would recommend them to any business."



*Made to fit your
tiles*

The door, frame and hinge mechanism are completely hidden behind the wall tiles when finished. The door is adjustable in 10 planes, enabling a skilled tiler to imperceptibly line up the grout gaps between the tiles on the door and the tiles on the surrounding wall.

Doors can be specified over 2m high by 750mm wide and will carry a heavy stone tile up to 22mm thick plus adhesive bed. Here is what a customer had to say recently of a doors that size fitted at Dublin Airport: "... the client architect's are extremely happy with the access doors, especially the tiled ones. They are the best they have come across and have asked if its possible to have your contact details."

Each door is made to measure so that the door tray accepts your tile combination and grout gap avoiding unsightly tile cuts. We provide cross section drawings for approval prior to manufacture and offer fire rated versions. As tile doors are more complex with many variables we ask you to call before specifying. We are always pleased to give advice both to the designer and the tiler on site.

'Classic Brand' Hinged Tile Door Specification

- Manufactured from 1.2mm 'Zintec' coated mild steel
- Finished in white polyester powder coat RAL 9010 20% Gloss
- Full length piano hinge preventing door drop and consequential tile damage
- Door face factory fitted with specialist waterproof tile substrate
- Touch Catch or Key operated budget lock from chrome sealed escutcheon
- Fire Rated options



Sizes:- Made to order to match your tile size

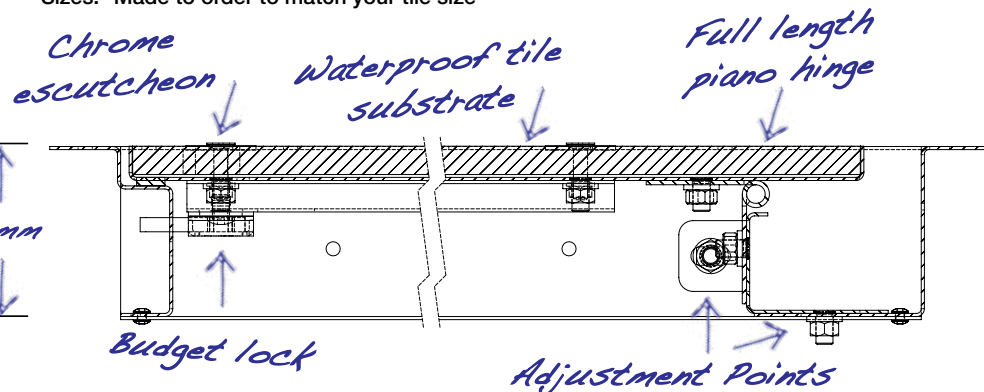

"I have been trading with The Access Panel Company for over 5 years. They have an exceptional level of customer service and a tailored CAD Drawing service which is tailored to my individual project needs. There is also such a high stock level that we can always depend on them for last minute orders. I can't recommend them enough."



Easy to fit

This panel was developed for occasional access where space and cost are important. The panel clips in at the bottom and is held shut with a budget lock opened via the chrome escutcheon or push catches. The pictures show a bath side where a deeper frame would be impossible to fit. The panel is made to your exact tile size so there are no unsightly tile cuts. The panel can be ordered with a visible frame edge which would protect the tiles as the panel is opened. Larger panels can be fitted with a retaining chain so if opened unexpectedly the panel will only open to 20 degrees and not fall out damaging the tiles. Our trained sales staff will advise which type of tile access panel is suitable for your application. Please call for advice before specifying.

“Classic Brand” Lift Off Tile Door Specification

- Manufactured from 1.2mm ‘Zintec’ coated mild steel
- Finished in white polyester powder coat RAL 9010 20% Gloss
- Lift off door location mechanism
- Door face factory fitted with specialist waterproof tile substrate
- Touch Catch or Key operated budget lock from chrome sealed escutcheon
- Door can be neoprene sealed for odour and moisture ingress prevention
- Fire Rated options



Sizes:- Made to order to match your tile size

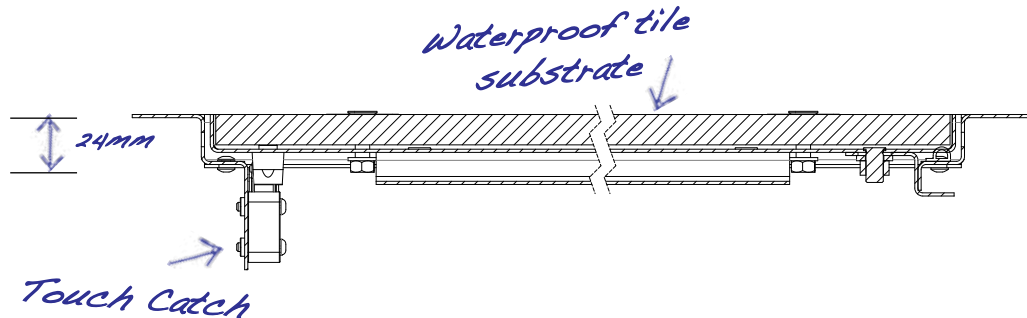

“Galliford Try have been purchasing access panels from The Access Panel Co. for at least 10 years now, and in that time have always found them to be competitive, open to negotiation when necessary, efficient, and above all friendly in their sales attitude. We would not hesitate in recommending them to other prospective clients.”



Over 1,000,000 Sold!

A very simple European made kit for all tile sizes which makes surprisingly effective and durable access points through tiles walls. To appreciate the simplicity look at the animated fitting guide on the website.

Alpro 2000

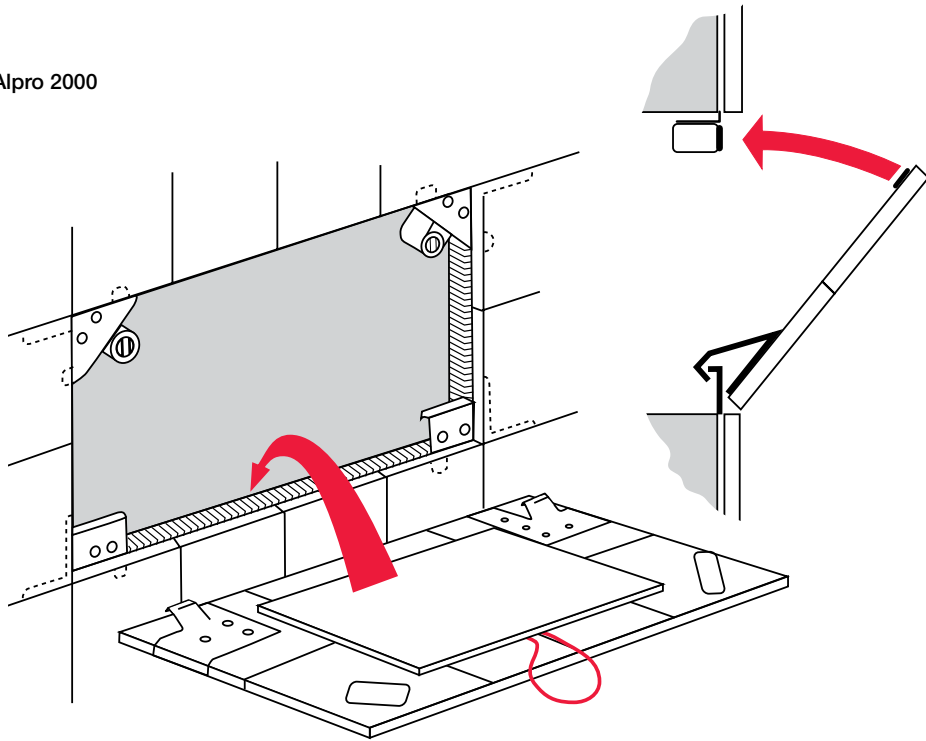

Alpro Clips

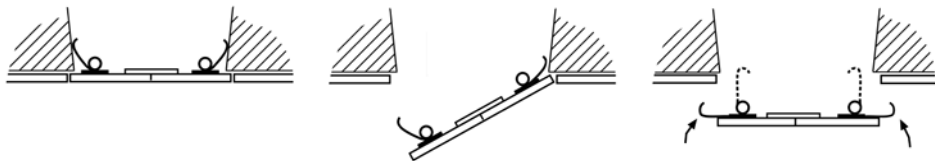

Alpro 2000



Alpro Clips

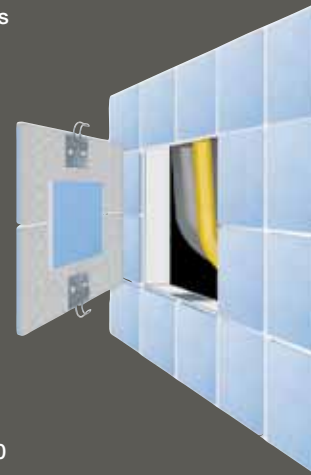

Alpro 2000



Super Alpro Tile Door



Decorative & functional

When all other features in your ceiling are round, continue the theme with a round access panel. Reassuringly expensive a round panel will maintain the purity of your overall design aesthetic. With no visible keyhole or hinge, the round panel will blend into your scheme and look like a designed architectural feature rather than an access point.

“Classic Brand” Round Panel Specification

- Circular access panels create round access points in walls & ceilings
- Finished in white polyester powder coat RAL 9010 20% Gloss
- Manufactured from 1.5mm ‘Zintec’ coated mild steel or aluminium
- Twist and Turn bayonet type operation
- 25 mm Beaded frame for tape & jointing on site or Picture Frame surround
- Complete with quick release retaining strap
- Non Fire rated
- Shadow gap options available
- Bespoke sizes available



Stock Sizes (mm)

300 450 600 diameter

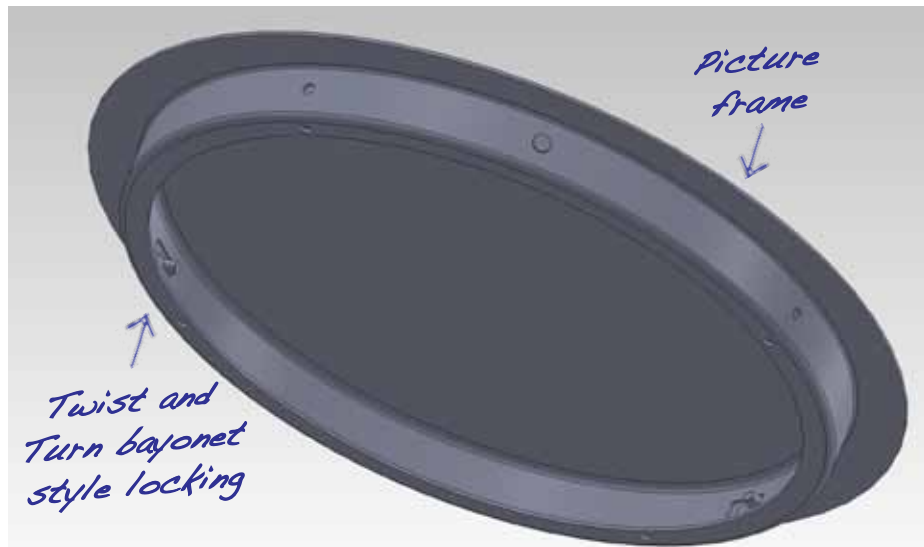

“Since our company started, The Access Panel Company has been our supplier of choice. Their support, friendly customer service and competitive pricing have enabled us to compete on larger contracts, giving us the edge over the competition.”



For Suspended Ceiling Systems

For occasional access just keep a few replacement tiles, but where regular access is needed then our panels fit into your grid system. We would recommend that for the front of house the model that accepts your ceiling tile into the door face will best maintain your look. For rear of house use the metal faced powder coated solution which will resist grubby fingers and damage better than the tiled faced version. Made to fit into standard grid modules or even accept perforated plasterboard for Rigitone acoustic ceilings, we have even made this model to accept a washable thick vinyl surface for a clean room environment.

“Classic Brand” Exposed Grid Panel Specification

- Single or Double door panel for ceiling access
- Manufactured from 1.2mm and 0.9mm ‘Zintec’ coated mild steel
- To fit into a standard T bar system with 12 or 24mm T’s
- Finished in white polyester powder coat RAL 9010 20% Gloss
- Budget lock operated with square drive ‘T’ key with Slik System invisible keyhole as standard or touch catch operation with safety chains or high security sealed lock options
- To take Grid tiles supplied by others, steel faced option available
- Non Fire rated



Standard Sizes (mm)

600 x 600 1200 x 600 1200 x 1200

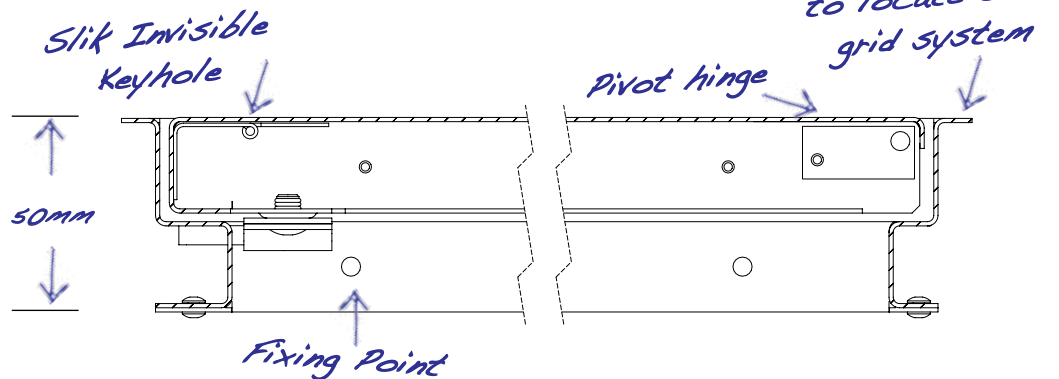

“After working on a number of our larger contracts I can say without reservation that whilst maintaining good value, service and punctual delivery The Access Panel Co helped us significantly reduce our on site installation times and subsequent decoration costs. In a fast moving environment where swift attention was required we were never left disappointed.”



Designed for air flow

The design of this very popular variety of panel allows a substantial passage of air to air conditioning units without resulting to more louvers or separate grills. Most commonly used in hotel rooms; the panel allows easy access to change or service the air conditioning unit. Careful design means no visible screw heads and a perfect blend with the surrounding ceiling. The picture shows a beaded frame panel installed at Holiday Inn Express.

“Classic Brand” Air Gap Panel Specification

- For airflow to concealed air conditioning units
- Manufactured from 1.2mm ‘Zintec’ coated mild steel
- Finished in white polyester powder coat RAL 9010 20% Gloss
- Full length hinge or pivot hinge to long edge unless requested otherwise
- Budget lock operated with square drive ‘T’ key with Slik System invisible keyhole as standard or touch catch operation with safety chains for ceilings or high security sealed lock options
- 25 mm Picture Frame surround or Simulated Bead Frame for tape & jointing on site
- Non Fire rated
- Air flow gaps to suit application.

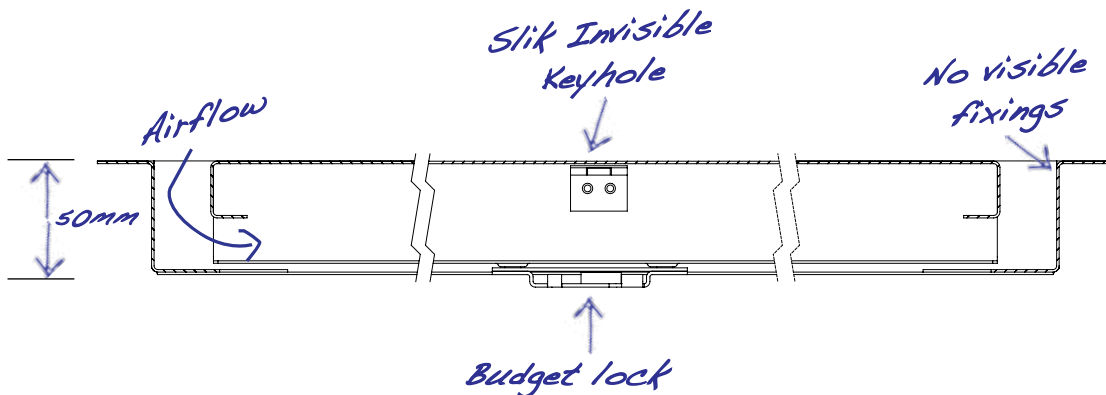

“I have been a customer of The Access Panel Company for 7 years and they provide a great range of products, excellent customer service with a helpful and friendly sales team”





Roof Hatches

We manufacture and stock a full range of bespoke and standard size hatches for all roof types. See online or our dedicated roof hatch brochure for more information.



BSI Plus



Lock Options



FB2 Fire Brigade Lock



Long Pole Key and SLIK Key Options



Slik System



Budget Lock with Key



Euro Profile Deadlock with Interchangeable Cylinder



Euro-profile 3 point lock



Radial Pin Tumbler Security Lock



Budget Lock



Touch Catch



Budget Lock with Triangular Security Insert

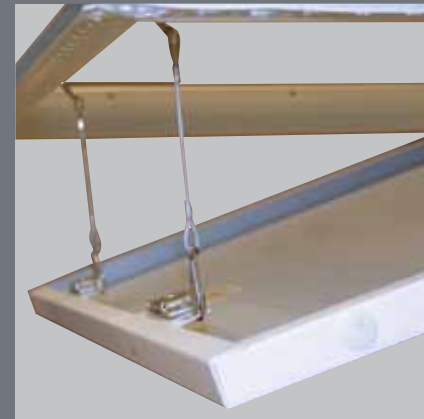

Retaining Chain with Door Open

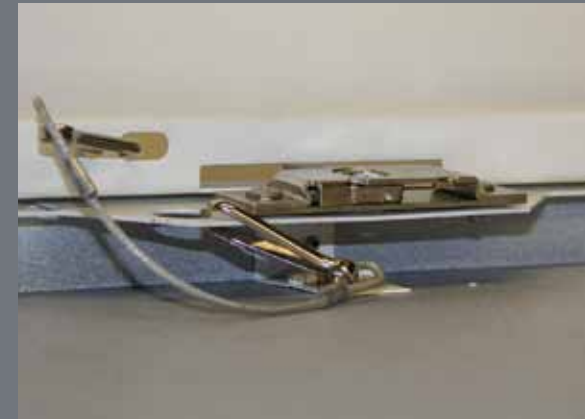

Retaining Chain Located into Pre-Punched Slots



We have in house production facilities capable of manufacturing a one off to an order for hundreds of panels. We supply the UK and International customers from our base in Scunthorpe, North Lincolnshire.

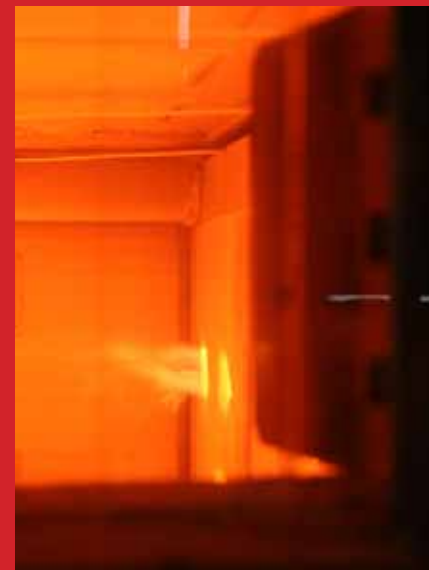
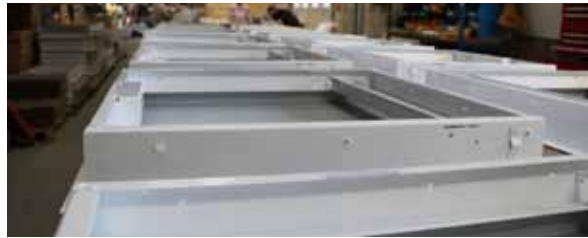



Project Showcase

We were pleased to be involved in this challenging London Gallery project designed by Zaha Hadid. This project pushed the sheetmetal boundaries with hardly a straight line in the building. The metal faced doors blended in perfectly with the specialised plaster finished walls.

