

FUMECADDIE™

MOBILE EXTRACTION UNIT

The FumeCaddie™ is directly connected to the vehicle or apparatus tailpipe with an easy-to-use nozzle*. The FumeCaddie's™ portable exhaust fan will remove the fumes from the source through a suction hose and deliver them to the outside of the building through the exhaust hose*.

The extractor consists of a powerful FUA-2100 single phase 50 Hz fan, a 5 m (16 ft) power cord and a motor starter with thermal breaker, all assembled on an easy to maneuver, ergonomic cart.

* hoses and nozzle need to be ordered separately.



APPLICATIONS

The FumeCaddie™ is intended to be used for the following applications:

- To eliminate hazardous vehicle exhaust emissions with our vehicle exhaust capture and removal systems for the following segments: fire and emergency stations, workshops and military facilities.



SPECIFICATIONS

■ Physical dimensions and properties	
Material cart	powder coated galvanized steel
Colour	basalt grey RAL 7011
Weight	approx. 45 kg (100 lbs) (excl. hose)
Dimensions	690 x 407 x 1067 mm (27 x 16 x 42 in.)
■ Ambient conditions	
Operating temperature:	
• min.	• -20°C (-4°F)
• nom.	• 20°C (68°F)
• max.	• 40°C (104°F)
Max. relative humidity	80%
Outdoor use allowed	no
Storage conditions	• -20 - 40°C (-4 - 104°F) • relative humidity max. 80%
■ Options and accessories	
Nozzles Hoses	
■ Where used	
Combustion engines with engines <3,5 l (trucks equipped with EGR excluded)	
■ Scope of supply	
FUA 2100 start/stop with thermal breaker FumeCaddie™ cart	
■ Order information	
Article no.	0000006413
Number/package	1
■ Shipping data	
Gross weight	60 kg (132 lbs)

Packing dimensions	1200 x 800 x 800 mm (47 x 32 x 32 in.)
Harmonized Tariff Code	84145925

DIMENSIONS

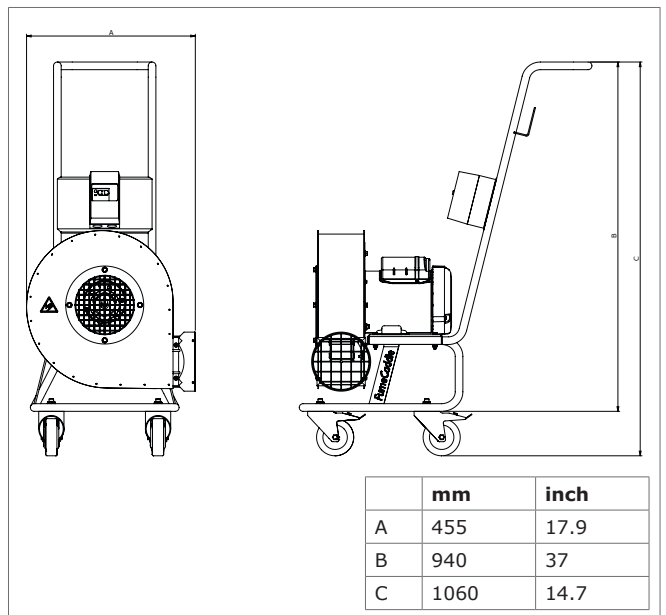

FEATURES & BENEFITS

- Excellent movability
- 800 m³/h at 800 Pa with a 10 meter 100 mm hose
- Integrated thermal breaker
- 5 m (16') electrical cord with 240V plug
- Installs in 5 minutes

Product type	FumeCaddie™
Article no.	0000006413
Product category	nozzles
Version	161120/0

Always check the latest version on www.plymovent.com