

GRENADIER Versatile planter



As UK based, designers and manufacturers, Street Design can manufacture and supply Grenadier planters from stock or they can be made to order. Choose the shape, plan sizes and heights of the planters. Choose from a range of material and finishes. Choose from a range of accessories to ensure that the Grenadier planter is manufactured to suit your specific scheme.

Grenadier planters are suitable for:

- roof garden planters
- modular planters
- tree planters
- large planters
- barrier planters
- shaped planters
- moveable planters

Planters & Planters with Benches

Planters, Accessories & other Products

Product Details

Product Specification

Accessories

Watering System

Adjustable Feet

Material Finishes

Material Specifications

Care & Maintenance

Street Design Limited

Unit 35
Hayhill Industrial Estate
Barrow upon Soar
Leicestershire LE12 8LD

Contact us:

Telephone: 01509 815335
Fax: 01509 815332
Email: sdl@street-design.com
Web site: www.street-design.com



1200x1200x920mm high Grenadier planters in natural finish FSC iroko hardwood

GRENADIER

Versatile planter



Street Design Limited

Unit 35
Hayhill Industrial Estate
Barrow upon Soar
Leicestershire LE12 8LD

Contact us:
Telephone: 01509 815335
Fax: 01509 815332
Email: sdl@street-design.com
Web site: www.street-design.com



PLANTERS & PLANTERS WITH BENCHES

Other sizes and shapes available



3VPGR 01
Square planter

Length: 1000mm
Width: 1000mm
Height: 920mm
All other sizes available



3VPGR 02
Rectangular planter

Length: 2000mm
Width: 1000mm
Height: 920mm
All other sizes available



3VPGR 03
Rectangular planter

Length: 2500mm
Width: 1000mm
Height: 920mm
All other sizes available



3VPGR 05
Tall planter

Length: 500mm
Width: 500mm
Height: 1210mm
All other sizes available



3VPGR 06
Raised planter

Length: 2000mm
Width: 750mm
Height: 800mm
All other sizes available

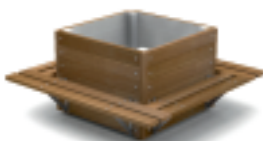

3VPGR 15
Planter with 4 benches

Length: 1950mm
Width: 1950mm
Height: 920mm
All other sizes available

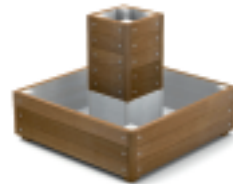

3VPGR 11
Tiered planter

Outer planter
Length: 1500mm
Width: 1500mm
Height: 485mm
Inner planter
Length: 500mm
Width: 500mm
Height: 1210mm
All other sizes available



3VPGR 12
Stepped planter

Length: 1800mm
Width: 600mm
Heights: 630, 1210mm
All other sizes available



3VPGR 17
Planter with benches

Length: 2500mm
Width: 1800mm
Height: 530mm
All other sizes available



3VPGR 19
Planter with benches

Length: 2800mm
Width: 435mm
Height: 530mm
All other sizes available



3VPGR 18
Planters with bench

Length: 5400mm
Width: 505mm
Height: 485mm
All other sizes available



3VPGR 20
Planter with benches

Length: 5810mm
Width: 800mm
Height: 530mm
All other sizes available



3VPGR 04
Large Grenadier planter

Length: 12500mm
Width: 2500mm
Height: 630mm
All other sizes available



3VPGR 07
Long Grenadier planter

Length: 10000mm
Width: 1000mm
Height: 920mm
All other sizes available



3VPGR 13
Large stepped planter

Length: 5000mm
Width: 1000mm
Height: 485, 775mm
All other sizes available



3VPGR 14
Planter with storage box

Length: 6000mm
Width: 1500mm
Height: 675mm
All other sizes available



3VPGR 16
Shaped planter & benches

Length: 6000mm
Width: 2000mm
Height: 775mm
All other sizes available

GRENADIER

Versatile planter



PLANTERS, ACCESSORIES & OTHER PRODUCTS

Other sizes and shapes available



3VPGR 21
Planter with tree benches
Length: 7994mm
Width: 1945mm
Height: 530mm
All other sizes available



3VPGR 22
Planter walling only
Length: 6165mm
Width: 2000mm
Height: 630mm
All other sizes available

Planters with Accessories



3VPGR 23
Planter with screen
Length: 2000mm
Width: 1000mm
Height: 1630mm
All other sizes available



3VPGR 24
Planter with trellis
Length: 2000mm
Width: 1000mm
Height: 1630mm
All other sizes available



3VPGR 25
Planter with pergola
Length: 2000mm
Width: 1000mm
Height: 2351mm
All other sizes available

Street Design Limited

Unit 35
Hayhill Industrial Estate
Barrow upon Soar
Leicestershire LE12 8LD

Contact us:
Telephone: 01509 815335
Fax: 01509 815332
Email: sdl@street-design.com
Web site: www.street-design.com



Co-ordinating products



3VPGR 26
Bench
Length: 2000mm
Width: 435mm
Height: 530mm
All other sizes available



3VPGR 27
Lounger
Length: 2000mm
Width: 2000mm
Height: 530mm
All other sizes available



3VPGR 28
Table
Length: 2000mm
Width: 987mm
Height: 808mm
All other sizes available



3VPGR 29
Storage box
Length: 2000mm
Width: 435mm
Height: 530mm
All other sizes available

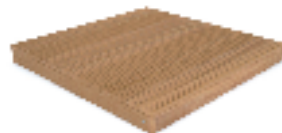

3VPGR 30
Decking pod
Length: 2000mm
Width: 2000mm
Height: 195mm
All other sizes available



3VPGR 31
Grass pod
Length: 2000mm
Width: 2000mm
Height: 195mm
All other sizes available

Shaped planters

Other sizes and shapes available



3VPGR 08
Planter with angled end
Length: 2800mm
Width: 1200mm
Height: 630mm
All other sizes available



3VPGR 09
L shaped planter
Length: 7500mm
Width: 5000mm
Height: 630mm
All other sizes available



3VPGR 10
Planter with angled ends
Length: 6244mm
Width: 4458mm
Height: 630mm
All other sizes available

GRENADIER Versatile planter



Street Design Limited

Unit 35
Hayhill Industrial Estate
Barrow upon Soar
Leicestershire LE12 8LD

Contact us:

Telephone: 01509 815335
Fax: 01509 815332
Email: sdl@street-design.com
Web site: www.street-design.com



PRODUCT DETAILS

General

The Grenadier external planter, is a versatile, multi-use and cost effective planter, available in a choice of materials and finishes to suit your scheme and budget.

The planter is available in either FSC iroko hardwood or a FSC treated European, joinery quality redwood. Planters up to 2.8x2.8m plan size will be delivered fully assembled ready for planting.

Larger planters will be manufactured in sections and delivered for assembly on site.

Other shapes can be manufactured and supplied including:- triangular, hexagonal, octagonal and any other irregular straight sided shape.

Planters can be manufactured with additional steel support to enable the planters to be moved when fully planted.

Construction

The Grenadier, all timber planter, is constructed by bolting 145x45mm section horizontal walling slats to 95x95mm section posts. A 45x45mm corner fillet is fitted into the external corner to ensure a neat detail.

The internal base is constructed using 100x47mm sawn treated softwood bearers, fixed to the posts and fitted to joist hangers fixed to the main bearers. Treated plywood sheeting is fixed down onto the bearers. 45mm high timber blocks are fitted to the underside of the bearers, to ensure that the load is safely transferred to the ground.

When fully constructed, the inside of the planter is fully lined with a geo-textile lining, that allows water to drain through whilst retaining the soil fines.



Section thro' planter

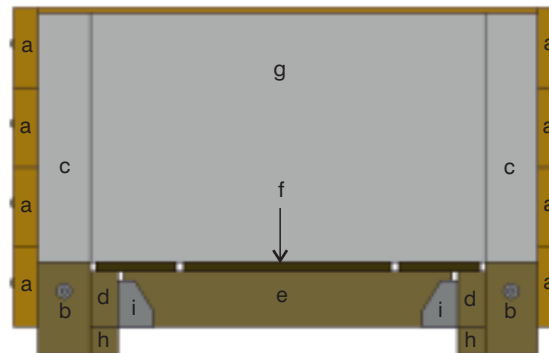

Key

- a - 145 x 45mm FSC horizontal timber wall slats
- b - M12 x 160mm cup square coachbolts
- c - 95 x 95mm FSC timber corner posts
- d - 100 x 47mm sawn FSC timber side bearers
- e - 100 x 47mm sawn FSC timber cross bearers
- f - 18mm FSC treated Eucalyptus plywood
- g - Terram 1000 geo-textile membrane filter lining
- h - 45mm high FSC timber blocks
- i - 45mm high FSC timber blocks

Typical plan sizes, heights and basic shapes of Grenadier planters

Plan dimensions and material options	all other sizes, heights and plan shapes can be manufactured and supplied					
Square	Planter heights					
0.5 x 0.5m	485mm	630mm	775mm	920mm	1065mm	1210mm
FSC softwood	•	•	•	•	•	•
FSC iroko hardwood	•	•	•	•	•	•
1.0 x 1.0m						
FSC softwood	•	•	•	•	•	•
FSC iroko hardwood	•	•	•	•	•	•
1.2 x 1.2m						
FSC softwood	•	•	•	•	•	•
FSC iroko hardwood	•	•	•	•	•	•
1.5 x 1.5m						
FSC softwood	•	•	•	•	•	•
FSC iroko hardwood	•	•	•	•	•	•
2.0 x 2.0m						
FSC softwood	•	•	•	•	•	•
FSC iroko hardwood	•	•	•	•	•	•
2.8 x 2.8m						
FSC softwood	•	•	•	•	•	•
FSC iroko hardwood	•	•	•	•	•	•
Rectangular						
1.0 x 0.5m	485mm	630mm	775mm	920mm	1065mm	1210mm
FSC softwood	•	•	•	•	•	•
FSC iroko hardwood	•	•	•	•	•	•
2.0 x 1.0m						
FSC softwood	•	•	•	•	•	•
FSC iroko hardwood	•	•	•	•	•	•
2.8 x 1.0m						
FSC softwood	•	•	•	•	•	•
FSC iroko hardwood	•	•	•	•	•	•

GRENADIER

Versatile planter



Street Design Limited

Unit 35
Hayhill Industrial Estate
Barrow upon Soar
Leicestershire LE12 8LD

Contact us:
Telephone: 01509 815335
Fax: 01509 815332
Email: sdl@street-design.com
Web site: www.street-design.com



PRODUCT SPECIFICATION

Technical information							
Material							
Horizontal walling slats	145 x 45mm FSC treated redwood or FSC iroko hardwood						
External corner detail	45 x 45mm FSC treated redwood or FSC iroko hardwood						
Internal corner posts	95 x 95mm FSC treated redwood or FSC iroko hardwood						
Base bearers	100 x 47mm FSC treated redwood						
Base flooring	18mm FSC treated Eucalyptus plywood						
Fixings	M12 size - bright zinc plated						
Standard finish	Natural						
Optional finish	Stained						
Accessories	Adjustable feet on a mild steel frame Tree anchor fittings Bench seating Watering systems LED lighting Base skirting boards Trellis panels and pergola structures Inner tower planters						
Guarantee	All planters are guaranteed for 15 years minimum						
Walling heights (mm)	485	630	775	920	1065	1210	
Planting depths (mm)	317	462	607	752	897	1042	
Weights							
FSC treated redwood (kgs / linear m.)	12	17	22	27	32	37	
FSC iroko hardwood (kgs / linear m.)	16	21	27	33	39	45	
FSC treated base (kgs / m ²)	11	11	11	11	11	11	
Light fill material can be based on:	1000 kgs / m ³						
Heavy fill material can be based on:	2000 kgs / m ³						

Timber policy

All treated softwood planters are manufactured using materials obtained from growers who operate under the Forest Stewardship Council (FSC).
All iroko hardwood planters are manufactured using materials obtained from growers who operate under the Forest Stewardship Council (FSC).

Construction

All Street Design products are designed and manufactured using only quality, durable materials, construction details and fixings, to provide a long-lasting, durable life expectancy.

Assembly

Planters up to 2.8 x 2.8m will be delivered to site fully assembled for off loading and positioning on site. Planters larger than 2.8m will be supplied in sections for bolting together on site.

Materials

Hardwood planters are constructed from FSC iroko hardwood, from sustainable sources. Softwood planters are constructed using FSC European redwood that has been Wolmanit CX treated, for a desired service life of 30 years minimum. All mild steel fixings will be M12 size and have a bright zinc plated finish. Planters will be fitted with a Terram 1000, geotextile filter fabric lining, which allows the water to drain through the planter, while retaining the fill material.

Standard finish

FSC treated softwood and iroko hardwood will be left natural to reduce the need for re-staining and help reduce maintenance costs.



FSC natural iroko hardwood with optional Henley bench seating



FSC natural iroko hardwood with curved Rochford benches



Large FSC natural treated softwood planters

Optional finish

If required, timber planters can be supplied with a stained finish using 3 coats of quick drying water based wood stain, to the colour of your choice. Material samples available on request.

Options

Grenadier planters are manufactured to order. Before we can manufacture the planters, we need to know the following:

- plan size and shapes
- heights
- material
- finish
- details of accessories

Accessories

To enhance your Grenadier planter and create a product that is suitable for your specific application, you can add from a range of planter accessories.

- Tree anchors
- Adjustable feet
- Watering system
- Integral bench seating
- LED lighting
- Internal steel frame
- Base skirting
- Pergola structures
- Trellis panels
- Plaques

GRENADIER

Versatile planter



ACCESSORIES

Grenadier planters can be manufactured and supplied to include a range of optional accessories.

Planters can incorporate; adjustable feet, tree anchor fittings, watering systems, bench seating, LED lighting, pergolas and trellis panels.

Adjustable feet

Grenadier planters can be manufactured with optional adjustable feet to allow the planter to be height adjusted to ensure that the top of the planter is level. The adjustable feet, allow the planter to be levelled after relocation. See separate page for Adjustable Feet details.

Watering system

Grenadier planters can be supplied with a choice of 2 watering systems. Street Design can supply either a reservoir system, with filler pipe or the Mona, subterranean tank system. See separate page for Watering System details.

LED lighting

Grenadier planters can be supplied with apertures cut into the sides of the planters or we can add timber bearers or metal brackets to accommodate your specified LED lighting products.

Please contact the sales office to discuss your specific requirements.

Moveable planters

Grenadier tree planters can be supplied with an internal steel frame to allow the planters to be moved whilst fully planted. The steel frame provides additional strength and ensures suitable supports for the forklift tines.

Pergola structures and trellis panels

By extending the planter posts, pergola structures and trellis panels can be integrated into the planter construction. Pergolas and trellis allow high level planting and create shaded areas.

Street Design Limited

Unit 35
Hayhill Industrial Estate
Barrow upon Soar
Leicestershire LE12 8LD

Contact us:

Telephone: 01509 815335
Fax: 01509 815332
Email: sdl@street-design.com
Web site: www.street-design.com



Tree anchor fittings

Grenadier tree planters can be fitted with galvanised mild steel tree anchor points. They can be fitted at the bottom of the planter to help support the root ball and they can be fitted at the top of the planter to help provide support for the tree. The tree anchors are manufactured using 25x5mm mild steel flat. They have two punched slots and are fitted to the projecting bolt ends on the inside of the planter. The tree anchors are hot dip galvanised.

Bench seating

Integral planter benches, with or without armrests, can be supplied with Grenadier planters. As standard 2 bench designs are available. Other designs can be included upon request. The Bexley bench consists of 4 no. 70x45mm timber slats and the Henley bench has 2 no. 145x45mm wide bench slats. The timber slats bolt onto galvanised mild steel brackets, bolted to the planter sides. Benches can be fitted to 1, 2, 3 or 4 sides to suit your requirements. The choice of material and finish is the same as for the planter. As standard the brackets will have a galvanised finish. As an optional extra, they can be polyester powder coated.

Storage boxes

Grenadier planters can be manufactured and supplied with integral storage boxes. The storage boxes are particularly useful for roof gardens planters, to provide storage areas for local residents. The hinged lids are supplied with a hasp and



Optional storage box



Optional timber trellis

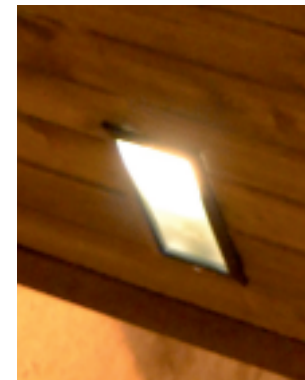

Optional aperture for LED light fitting



Optional Henley planter bench

Planter bench configurations



bench on 1 side



bench on 2 sides opposite



bench on 2 sides adjacent



bench on 2 sides adjacent (mitred)



bench on 3 sides



bench on 3 sides (mitred)



bench on 4 sides



bench on 4 sides (mitred)



WATERING SYSTEMS

Watering System 1 - Street Design reservoir system

The Street Design watering accessory is a reservoir system with hydroleca sacks, that maximises the available water.

The system ensures the optimum use of the water and nutrients, delivering the maximum quantity directly to the roots of the plants, resulting in improved root development and optimal plant growth.

General

The system consists of a 300 micron thick black polythene liner, hydroleca (pulverised ash granules) sacks and a rigid plastic filler pipe.

The system delivers water directly to the roots via 50mm diameter, rigid plastic pipe, eliminating water wastage. This encourages deep root growth, improving long term drought resistance. The high level filler pipe provides an easy access point for watering and soluble fertiliser application.

Installation

Planters are supplied with the Water System 1 already installed.

Ensure the hydroleca sacks are in the correct position. They will move during transportation. Check that all the plastic pipe connections are properly fitted. The planter is ready for drainage material, filling and planting.

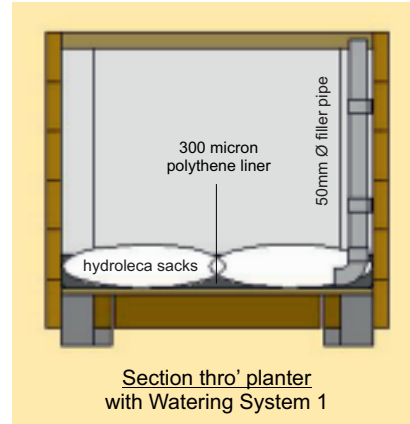

Polythene liner with filler pipe



Hydroleca sacks laid out in base of planter

Watering System 2 - MONA subterranean tank system

Mona watering system

Factory fitted into planter / tree container

The Mona Plant System (MPS) is an advanced, well proven and easy to use subterranean irrigation system. It is the cost effective and environmentally friendly solution for both interior and exterior landscaping.

The Mona Plant System ensures that the water and nutrients are delivered in the right quantity to the root of the plants, resulting in improved root development and optimal plant growth.

General

The system consists of storage tanks, flexible linking pipes and a flexible filler pipe with filler pipe cap. The system delivers water directly to the roots via capillary action, eliminating water wastage. This encourages deep root growth, improving long term drought resistance. The cap and lid provides an easy access point for watering and soluble fertiliser application.

Factory installation

All necessary water tanks, pipes, end caps and air pipes with level indicator, are factory fitted into the planters / tree containers, prior to delivery.

Filling planters

Ensure that the distance between the top of the link tank and the lowest part of the root does not exceed 150mm.

For full details visit: www.green-tech.co.uk



Water storage tanks and filler pipe



Planter ready for soil and planting



Completed planter

GRENADIER

Versatile planter



ADJUSTABLE FEET

General details

As an extra cost option, Street Design planters can be supplied with adjustable feet. They allow the planter to be levelled, before filling and planting.

Adjustable feet are particularly useful if the planters are likely to be relocated to a new position.

The adjustable foot screw fits into a hex nut, located on the underside of the planter base.

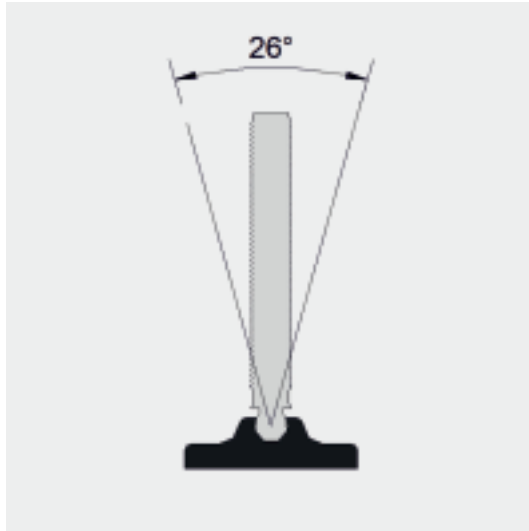

Specification

The adjustable foot comprises of a M30 Ø threaded bar, with spherical end section, press fitted into a black reinforced polyamide base. The swivel base can tilt through 360° to accommodate sloping ground levels. The threaded bar is BZP (bright zinc plated) treated.

Street Design Limited

Unit 35
Hayhill Industrial Estate
Barrow upon Soar
Leicestershire LE12 8LD

Contact us:

Telephone: 01509 815335
Fax: 01509 815332
Email: sdl@street-design.com
Web site: www.street-design.com

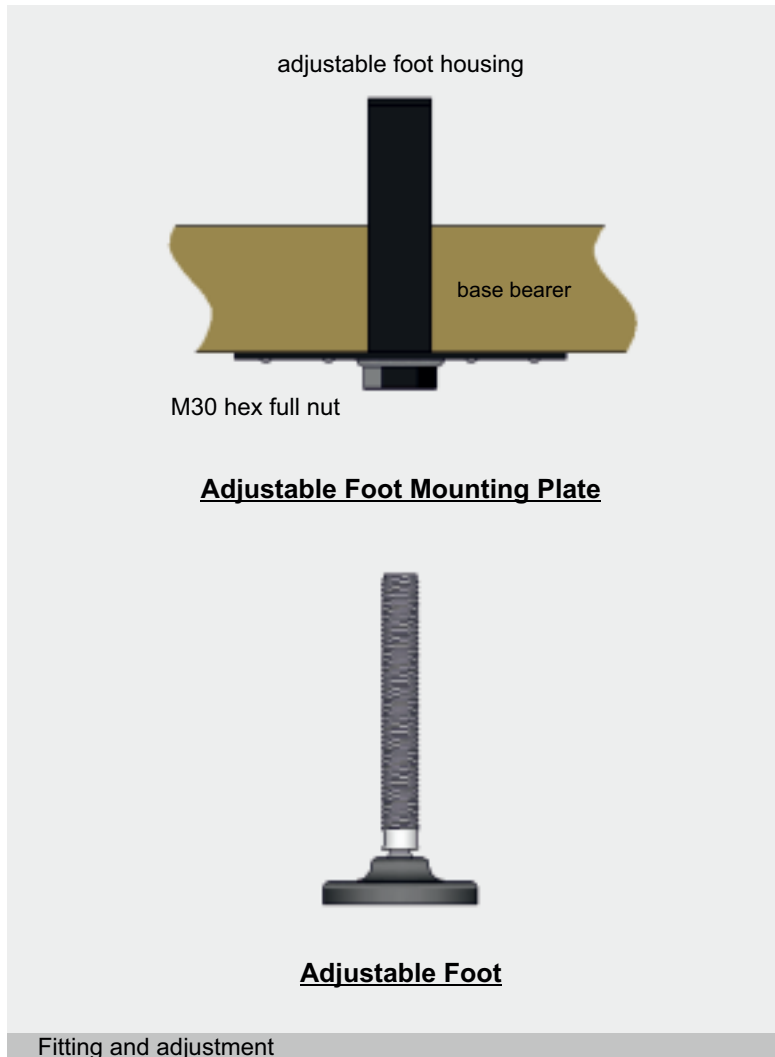

Fitting and adjustment

The M30 adjustable foot with swivel base, is screwed into adjustable foot mounting plate.
The mild steel mounting plate with adjustable foot housing, is fixed to the underside of the planter base.
A M30 hex full nut is welded to the underside of the mounting plate.
The adjustable foot is adjusted with a 26mm wrench.

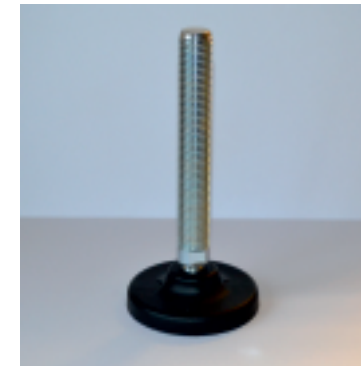

Base diameter

M30 adjustable foot with swivel base.
The base diameter is 122mm.

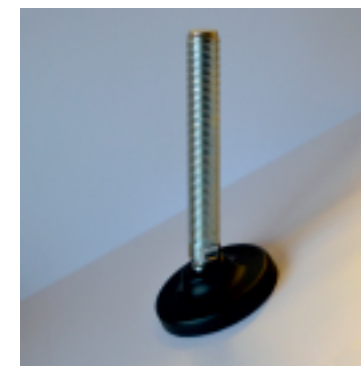

Swivel base

The swivel base can adjust to allow for sloping ground with a fall of up to 1 in 2.06 (26°).



Bolt down base

For extra security, it is possible to drill and bolt through the base of the adjustable feet.

GRENADIER

Versatile planter



Street Design Limited

Unit 35
Hayhill Industrial Estate
Barrow upon Soar
Leicestershire LE12 8LD

Contact us:

Telephone: 01509 815335
Fax: 01509 815332
Email: sdl@street-design.com
Web site: www.street-design.com



MATERIAL FINISHES

Standard finish

FSC treated redwood standard finish

As standard, all FSC treated redwood planters will be supplied with a natural finish. The preservative treatment process will colour the timber a light brown/green.



Aged natural treated redwood

Left to weather naturally, the timber will eventually turn a silver grey colour.



FSC iroko hardwood standard finish

As standard, all FSC iroko hardwood planters will be supplied with a natural finish. Due to the nature of the material and the density of the grain, iroko hardwood is not capable of taking a preservative treatment. Iroko hardwood is a naturally durable material, giving a life expectancy in excess of a treated softwood.



Aged natural iroko hardwood

Left to weather naturally, the timber will eventually turn a silver grey colour.



Optional finishes at extra cost

FSC treated redwood wood optional finish

As an optional extra, the FSC treated redwood can be supplied with a stained finish. This will be applied after the timber treatment process. The standard stain will be 3 coats of Ronseal quick drying water based stain. The standard colour will be teak. Other stains and colours can be applied upon request.

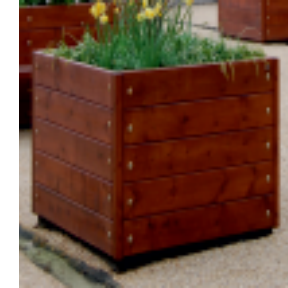

Optional teak stained finish

FSC iroko hardwood optional finish

As an optional extra, the FSC iroko hardwood planters can be supplied with a stained finish. The standard stain will be 3 coats of Ronseal quick drying water based stain. The standard colour will be teak. Other stains and colours can be applied upon request.

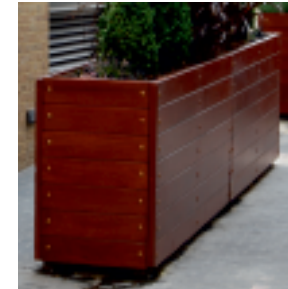

Optional teak stained finish

Alternative opaque wood stain finishes

As an optional extra, FSC timber planters can be supplied with an opaque stained finish. Three coats of stain will be applied. If required, RAL colours can be specified.



Optional RAL 7012 opaque stained finish

GRENADIER

Versatile planter



Street Design Limited

Unit 35
Hayhill Industrial Estate
Barrow upon Soar
Leicestershire LE12 8LD

Contact us:
Telephone: 01509 815335
Fax: 01509 815332
Email: sdl@street-design.com
Web site: www.street-design.com



MATERIAL SPECIFICATION

Standard planter

Posts

FSC 95x95mm FIN PAR Wolmanit CX treated European redwood.

Base bearers

FSC 100x47mm section sawn, Wolmanit CX treated European redwood.

Wall slats

FSC 145x45mm FIN PAR Wolmanit CX treated European redwood or FSC 145x45mm FIN PAR iroko hardwood.

Corner fillets

FSC 45x45mm FIN PAR Wolmanit CX treated European redwood or FSC iroko hardwood.

Base floor

18mm FSC Eucalyptus treated plywood.

Internal lining

Geotextile membrane.

Fixing bolts

M12x160mm coach bolts with a BZP finish.

Joist hangers

LUS/230/50 U sheer light nailing hangers with a BZP finish.

Optional planter accessories

Adjustable feet

M30 adjustable feet with swivel base. See Adjustable Foot page for full details.

Tree anchors

25x5mm mild steel flat, hot dip galvanised.

Watering system

Choose either the Street Design reservoir system or the Mona tank system. See Watering System page for full details.

Planter benches

FSC bench slats to match planter material in either FSC treated European redwood or iroko hardwood, bolted to hot dip galvanised mild steel bench brackets.

Optional planter accessories continued

Base skirting

12mm thick Marine grade plywood boards, screw fixed to blocks fixed to the underside of the planter.

Moveable planters

Grenadier planters can be manufactured with an internal mild steel frame.

Pergola structures

Pergola structures can be manufactured as an integral part of the planter construction. The corner post can be extended to carry the upper horizontal 145x45mm section timber bearers and cross bearers.

Trellis panels

Trellis panels can be manufactured as an integral part of the planter construction. The corner post can be extended to carry the horizontal and vertical trellis timber slats.

LED lighting

Material samples

Material samples are available on request.

Guarantee

All planters are guaranteed for 15 years minimum. This guarantee is a minimum and is dependant on the product not being misused or abused. All the materials, treatments and construction will allow for a life expectancy considerably longer than this.

General specification

Construction

All Street Design products are designed and manufactured using only quality, durable materials, construction details and fixings, to provide a long-lasting, durable life expectancy.

Assembly

Grenadier planters up to 2.8 x 2.8m will be delivered to site fully assembled for off loading and positioning on site. Planters larger than 2.8m will be supplied in sections for bolting together on site.

Timber policy

All treated softwood products are manufactured using materials obtained from growers who operate under the Forest Stewardship Council (FSC). All iroko hardwood products are manufactured using materials obtained from growers who operate under the Forest Stewardship Council (FSC).

Materials

Hardwood products are constructed using FSC iroko hardwood, from sustainable sources. Softwood products are constructed using FSC European redwood that has been Wolmanit CX treated, for a desired service life of 30 years minimum. All mild steel fabricated components will be hot dip galvanised after fabrication to BS EN ISO 1461:2009.

All stainless steel fabricated components will be grade 304. Grade 316 can be specified if the location or project requires it.

All mild steel fixings will be bright zinc plated, and all stainless steel fixings will be A2 (grade 304). A4 (grade 316) can be specified if the location or project requires it.

Planters will be fitted with a geotextile filter fabric lining, which allows the water to drain through the planter, while retaining the fill material.

Finishes

FSC treated softwood and iroko hardwood will be left natural to reduce the need for re-staining and help reduce maintenance costs. If required, timber planters can be supplied with a stained finish using 3 coats of quick drying water based wood stain, to the colour of your choice.

Mild steel components will be left with a galvanised finish only. If required, after hot dip galvanising, the mild steel components can be polyester powder coated, to the colour of your choice. The galvanised parts are prepped, treated and sprayed with the polyester powder, before being baked in an oven.

Stainless steel components will have a brushed finish. If required, the stainless steel components can be supplied with a mirror polished or bead blasted finish.

GRENADIER

Versatile planter



Street Design Limited

Unit 35
Hayhill Industrial Estate
Barrow upon Soar
Leicestershire LE12 8LD

Contact us:
Telephone: 01509 815335
Fax: 01509 815332
Email: sdl@street-design.com
Web site: www.street-design.com



CARE & MAINTENANCE

General

All Grenadier planter products are manufactured using quality materials, treatments and finishes. The timber components are manufactured from either FSC treated redwood or FSC iroko hardwood. All products require a varied amount of maintenance, depending on the environment, usage and weather conditions. Natural timber will only require cleaning. In time, stained timber will require re-coating.

Maintaining the standard FSC treated redwood finish

Natural finish treated redwood can be washed down with a mild detergent. More stubborn surface marks can be removed with a light, hand sand with a 120 grit, or higher grade sandpaper. Excessive sanding should be avoided.



Maintaining the standard FSC iroko hardwood finish

Natural finish iroko hardwood can be washed down with a mild detergent. More stubborn surface marks can be removed with a light, hand sand with a 120 grit, or higher grade sandpaper. Excessive sanding should be avoided.

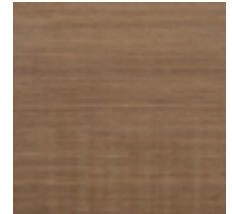

Maintaining the optional FSC treated redwood finish

Stained, treated redwood will need to be re-coated after a period of time. The stain can either start to fade, become dull (oxidised) or incur some surface break up. Lightly sand down the timber using a 120 grit, or higher grade sandpaper. We recommend that the timber is re-stained with the original stain colour and manufacturer. Details can be obtained from Street design Limited. Apply the stain evenly, with brush strokes running parallel with the woodgrain, in thin layers, building up the finish as recommended by the stain manufacturer.

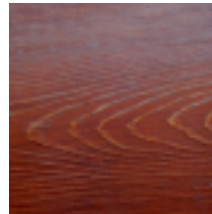

Maintaining the optional FSC iroko hardwood finish

Stained, iroko hardwood will need to be re-coated after a period of time. The stain can either start to fade, become dull (oxidised) or incur some surface break up. Lightly sand down the timber using a 120 grit, or higher grade sandpaper. We recommend that the timber is re-stained with the original stain colour and manufacturer. Details can be obtained from Street design Limited. Apply the stain evenly, with brush strokes running parallel with the woodgrain, in thin layers, building up the finish as recommended by the stain manufacturer.

