

## STOCKPORT planter

As UK based, designers and manufacturers, Street Design can manufacture and supply Stockport planters to order. Choose the shape, plan sizes and heights of the planters. Choose from a range of material and finishes. Choose from a range of accessories to ensure that the Stockport planter is manufactured to suit your specific scheme.

Stockport planters are suitable for:

- circular planters
- elliptical planters
- curved planters
- roof garden planters
- tree planters
- moveable planters

Product Details

Product Specification

Accessories

Watering System

Adjustable Feet

Material Finishes

Material Specifications

Care & Maintenance



*Elliptical Stockport planters in natural finish FSC treated softwood with dull polished stainless steel top and bottom capping. Shown with optional stainless steel plaques.*

# STOCKPORT planter

## PRODUCT DETAILS

### General

The Stockport external planter, is a versatile, multi-use and cost effective timber and metal planter, available in a choice of materials and finishes to suit your scheme and budget. The planter is available in either FSC iroko hardwood or a FSC treated European, joinery quality redwood. Planters up to 2.8x2.8m plan size will be delivered fully assembled ready for planting. Larger planters will be manufactured in sections and delivered for assembly on site. Shaped planters can be manufactured and supplied including:- square, rectangular, full circular, half circular, quarter circular and elliptical. Planters are manufactured with internal steel frames to enable the planters to be moved when fully planted.

### Construction

The Stockport, timber and metal planter, is constructed by bolting 95x45mm section vertical walling slats to an internal steel frame. The square and rectangular planters will have 45x45mm corner fillets fitted into the external corners.

The internal base is constructed using 75x50x3mm mild steel RHS and 75x50x6mm mild steel angle. The 50x10mm mild steel flat uprights and cross brace straps support the horizontal 25x5mm mild steel flats. Treated plywood sheeting is laid onto the base. 50mm high mild steel planter feet are fitted to the underside of the base frame, to ensure that the load is safely transferred to the ground.

The planter has 60.3mm Ø, mild or stainless steel CHS top and bottom rails.

When fully constructed, the inside of the planter is fully lined with a geo-textile lining, that allows water to drain through whilst retaining the soil fines.

### Street Design Limited

Unit 35  
Hayhill Industrial Estate  
Barrow upon Soar  
Leicestershire LE12 8LD

### Contact us:

Telephone: 01509 815335  
Fax: 01509 815332  
Email: [sdl@street-design.com](mailto:sdl@street-design.com)  
Web site: [www.street-design.com](http://www.street-design.com)



Section thro' planter

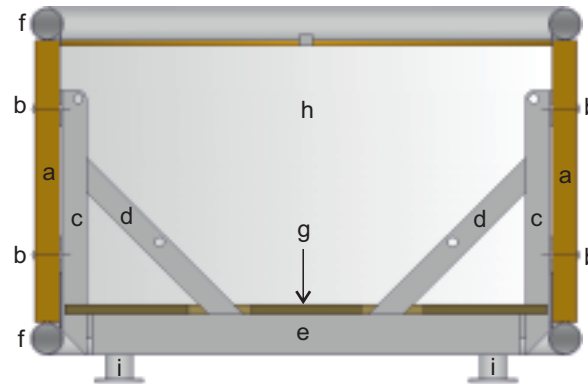

- Key**
- a - 95 x 45mm FSC vertical timber wall slats
  - b - M10 x 65mm cup square coachbolts
  - c - 50 x 10mm mild steel flat uprights
  - d - 50x10mm mild steel flat cross brace
  - e - 75x50x3mm mild steel RHS bearers
  - f - 60.3mm Ø x 3mm mild steel CHS rails
  - g - 18mm FSC treated Eucalyptus plywood
  - h - Geotextile membrane filter lining
  - i - 50mm high FSC timber blocks

### Typical plan sizes, heights and basic shapes of Stockport planters

Plan dimensions and material options	all other sizes, heights and plan shapes can be manufactured and supplied				
<b>Square</b>	Planter heights				
1.0 x 1.0m	460mm	660mm	860mm	1060mm	1260mm
FSC softwood	•	•	•	•	•
FSC iroko hardwood	•	•	•	•	•
1.5 x 1.5m					
FSC softwood	•	•	•	•	•
FSC iroko hardwood	•	•	•	•	•
2.0 x 2.0m					
FSC softwood	•	•	•	•	•
FSC iroko hardwood	•	•	•	•	•
<b>Rectangular</b>	Planter heights				
2.0 x 1.0m	460mm	660mm	860mm	1060mm	1260mm
FSC softwood	•	•	•	•	•
FSC iroko hardwood	•	•	•	•	•
2.8 x 1.0m					
FSC softwood	•	•	•	•	•
FSC iroko hardwood	•	•	•	•	•
<b>Full circular</b>	Planter heights				
1.0m diameter	460mm	660mm	860mm	1060mm	1260mm
FSC softwood	•	•	•	•	•
FSC iroko hardwood	•	•	•	•	•
1.5m diameter					
FSC softwood	•	•	•	•	•
FSC iroko hardwood	•	•	•	•	•
2.0m diameter					
FSC softwood	•	•	•	•	•
FSC iroko hardwood	•	•	•	•	•

# STOCKPORT planter

## PRODUCT SPECIFICATION

### Street Design Limited

Unit 35  
Hayhill Industrial Estate  
Barrow upon Soar  
Leicestershire LE12 8LD

Contact us:  
Telephone: 01509 815335  
Fax: 01509 815332  
Email: [sdl@street-design.com](mailto:sdl@street-design.com)  
Web site: [www.street-design.com](http://www.street-design.com)



Technical information						
<b>Material</b>						
Vertical walling slats	95 x 45mm FSC treated redwood or FSC iroko hardwood					
External corner detail	45 x 45mm FSC treated redwood or FSC iroko hardwood					
Top and bottom rails	60.3mm Ø x 3mm mild or stainless steel CHS					
Internal frame uprights and cross brace	45x10mm mild steel flat					
Base frame bearers	75x50x3mm mild steel RHS and 75x50x6mm mild steel angle					
Planter feet	48.3mm Ø x 3mm mild steel SHS with 88.9mm Ø discs					
Base flooring	18mm FSC treated Eucalyptus plywood					
Fixings	M10 size - bright zinc plated					
Standard finish	Natural with galvanised or dull polished top and bottom rails					
Optional finish	Stained with powder coated or mirror polished rails					
<b>Accessories</b>	Adjustable feet on a mild steel frame Tree anchor fittings Bench seating Watering systems LED lighting Base skirting boards Trellis panels and pergola structures Inner tower planters					
<b>Guarantee</b>	All planters are guaranteed for 15 years minimum					
<b>Planter heights (mm)</b>	460	660	860	1060	1260	1460
<b>Planting depths (mm)</b>	232	432	632	832	1032	1232
<b>Weights</b>						
FSC treated redwood ( kgs / linear m.)	17	23	29	35	41	47
FSC iroko hardwood ( kgs / linear m.)	20	27	34	41	48	55
FSC treated base ( kgs / m <sup>2</sup> )	15	15	15	15	15	15
Light fill material can be based on:	1000 kgs / m <sup>3</sup>					
Heavy fill material can be based on:	2000 kgs / m <sup>3</sup>					

### Timber policy

All treated softwood planters are manufactured using materials obtained from growers who operate under the Forest Stewardship Council (FSC).

All iroko hardwood planters are manufactured using materials obtained from growers who operate under the Forest Stewardship Council (FSC).

### Construction

All Street Design products are designed and manufactured using only quality, durable materials, construction details and fixings, to provide a long-lasting, durable life expectancy.

### Assembly

Planters up to 2.8 x 2.8m will be delivered to site fully assembled for off loading and positioning on site. Planters larger than 2.8m will be supplied in sections for bolting together on site.

### Materials

Hardwood planters are constructed from FSC iroko hardwood, from sustainable sources. Softwood planters are constructed using FSC European redwood that has been Wolmanit CX treated, for a desired service life of 30 years minimum. All mild steel fixings will be M10 size and have a bright zinc plated finish. Planters will be fitted with a geotextile filter fabric lining, which allows the water to drain through the planter, while retaining the fill material.

### Standard finish

FSC treated softwood and iroko hardwood will be left natural to reduce the need for re-staining and help reduce maintenance costs.



FSC natural iroko hardwood rectangular planters in manufacture



FSC natural iroko hardwood full circular planter with spalling planter bench



Large FSC natural treated softwood planters

### Optional finish

If required, timber planters can be supplied with a stained finish using 3 coats of quick drying water based wood stain, to the colour of your choice. Material samples available on request.

### Options

Stockport planters are manufactured to order. Before we can manufacture the planters, we need to know the following:

- plan size and shapes
- heights
- material
- finish
- details of accessories required

### Accessories

To enhance your Stockport planter and create a product that is suitable for your specific application, you can add from a range of planter accessories.

- Tree anchors
- Adjustable feet
- Watering system
- Integral bench seating
- Inner tower planters
- Base skirting
- Pergola structures
- Trellis panels
- Plaques

# STOCKPORT planter

## ACCESSORIES

Stockport planters can be manufactured and supplied to include a range of optional accessories.

Planters can incorporate; adjustable feet, tree anchor fittings, watering systems, bench seating, tree surrounds and raised inner planters.

### Adjustable feet

Stockport planters can be manufactured with optional adjustable feet to allow the planter to be height adjusted to ensure that the top of the planter is level. The adjustable feet, allow the planter to be levelled after relocation. See separate page for Adjustable Feet details.

### Watering system

Stockport planters can be supplied with a choice of 2 watering systems. Street Design can supply either a reservoir system, with filler pipe or the Mona, subterranean tank system. See separate page for Watering System details.

### Timber slatted tree surround

Stockport planters can be supplied with optional timber slatted tree surrounds. The timber will match the planter timber and will be supplied in sections for fitting around the tree on site.

### Tree anchor fittings

Stockport planters can be fitted with galvanised mild steel tree anchor points. They can be fitted at the bottom of the planter to help support the root ball and they can be fitted at the top of the planter to help provide support for the tree. The tree anchors are manufactured using 25x5mm mild steel flat. They have two punched slots and are fitted to the projecting bolt ends on the inside of the planter. The tree anchors are hot dip galvanised.

### Inner tower planter

The Stockport planter is ideally suited to include raised inner planters that can be used to introduce raised or feature planting. The inner

## Street Design Limited

Unit 35  
Hayhill Industrial Estate  
Barrow upon Soar  
Leicestershire LE12 8LD

## Contact us:

Telephone: 01509 815335  
Fax: 01509 815332  
Email: [sdl@street-design.com](mailto:sdl@street-design.com)  
Web site: [www.street-design.com](http://www.street-design.com)



planters are manufacture as part of the main planter and are delivered fully assembled ready for planting.

### Bench seating

Integral planter benches, with or without armrests, can be supplied with Stockport planters. A number of bench designs are available to suit your requirements. The benches bolt onto galvanised mild steel brackets, attached to the planter sides. Benches can be fitted to 1, 2, 3 or 4 sides to suit your requirements.



Optional Spalding curved planter bench



Optional inner raised planter

### LED lighting

Stockport planters can be supplied with apertures cut into the sides of the planters or we can add timber bearers or metal brackets to accommodate your specified LED lighting products. Please contact the sales office to discuss your specific requirements.



Optional timber slatted tree surround



Optional aperture for LED light fitting

### Square & rectangular planter bench configurations

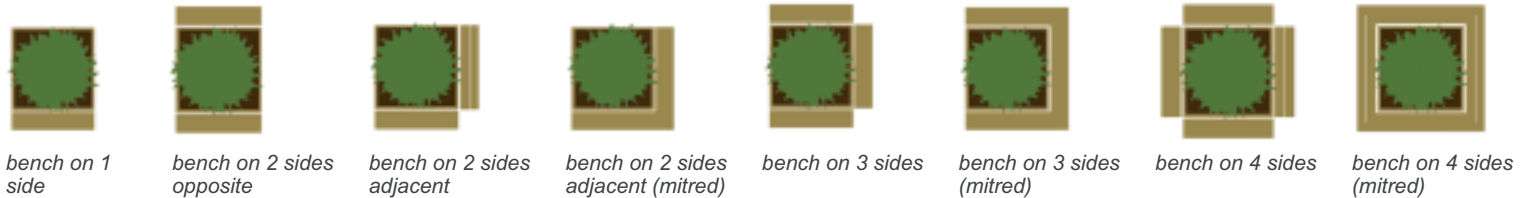

### Full circular bench configurations



Full circular planters can have quarter, half or full circular planter benches

### Half circular bench configurations



Half circular planters can have planter benches to the straight side only, the curved side only or both the straight and curved sides

# STOCKPORT planter

## WATERING SYSTEMS

### Street Design Limited

Unit 35  
Hayhill Industrial Estate  
Barrow upon Soar  
Leicestershire LE12 8LD

### Contact us:

Telephone: 01509 815335  
Fax: 01509 815332  
Email: [sdl@street-design.com](mailto:sdl@street-design.com)  
Web site: [www.street-design.com](http://www.street-design.com)



## Watering System 1 - Street Design reservoir system

The Street Design watering accessory is a reservoir system with hydroleca sacks, that maximises the available water.

The system ensures the optimum use of the water and nutrients, delivering the maximum quantity directly to the roots of the plants, resulting in improved root development and optimal plant growth.

### General

The system consists of a 300 micron thick black polythene liner, hydroleca (pulverised ash granules) sacks and a rigid plastic filler pipe.

The system delivers water directly to the roots via 50mm diameter, rigid plastic pipe, eliminating water wastage. This encourages deep root growth, improving long term drought resistance. The high level filler pipe provides an easy access point for watering and soluble fertiliser application.

### Installation

Planters are supplied with the Water System 1 already installed.

Ensure the hydroleca sacks are in the correct position. They will move during transportation. Check that all the plastic pipe connections are properly fitted. The planter is ready for drainage material, filling and planting.

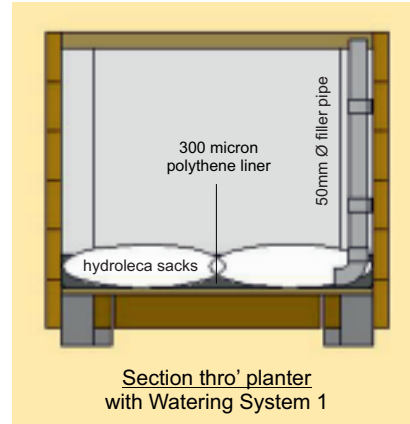

Section thro' planter with Watering System 1



Polythene liner with filler pipe



Hydroleca sacks laid out in base of planter

## Watering System 2 - MONA subterranean tank system

### Mona watering system

Factory fitted into planter / tree container

The Mona Plant System (MPS) is an advanced, well proven and easy to use subterranean irrigation system. It is the cost effective and environmentally friendly solution for both interior and exterior landscaping.

The Mona Plant System ensures that the water and nutrients are delivered in the right quantity to the root of the plants, resulting in improved root development and optimal plant growth.

### General

The system consists of storage tanks, flexible linking pipes and a flexible filler pipe with filler pipe cap. The system delivers water directly to the roots via capillary action, eliminating water wastage. This encourages deep root growth, improving long term drought resistance. The cap and lid provides an easy access point for watering and soluble fertiliser application.

### Factory installation

All necessary water tanks, pipes, end caps and air pipes with level indicator, are factory fitted into the planters / tree containers, prior to delivery.

### Filling planters

Ensure that the distance between the top of the link tank and the lowest part of the root does not exceed 150mm.

For full details visit: [www.green-tech.co.uk](http://www.green-tech.co.uk)



Water storage tanks and filler pipe



Planter ready for soil and planting



Completed planter

# STOCKPORT planter

## ADJUSTABLE FEET

### General details

As an extra cost option, Street Design planters can be supplied with adjustable feet. They allow the planter to be levelled, before filling and planting.

Adjustable feet are particularly useful if the planters are likely to be relocated to a new position.

The adjustable foot screw fits into a hex nut, located on the underside of the planter base.

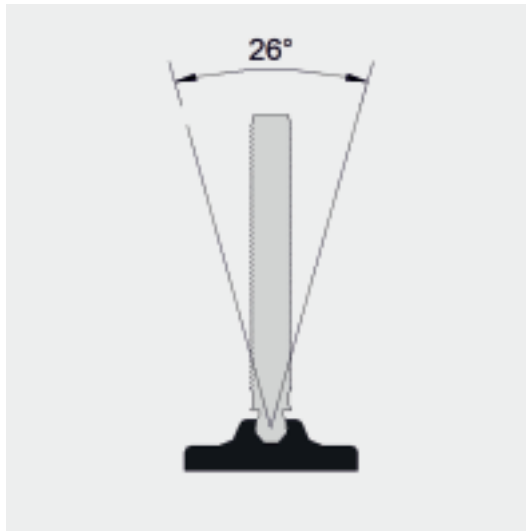

### Specification

The adjustable foot comprises of a M30 Ø threaded bar, with spherical end section, press fitted into a black reinforced polyamide base. The swivel base can tilt through 360° to accommodate sloping ground levels. The threaded bar is BZP (bright zinc plated) treated.

### Street Design Limited

Unit 35  
Hayhill Industrial Estate  
Barrow upon Soar  
Leicestershire LE12 8LD

### Contact us:

Telephone: 01509 815335  
Fax: 01509 815332  
Email: [sdl@street-design.com](mailto:sdl@street-design.com)  
Web site: [www.street-design.com](http://www.street-design.com)



adjustable foot housing

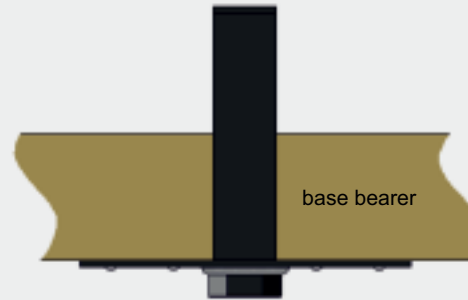

M30 hex full nut

### Adjustable Foot Mounting Plate

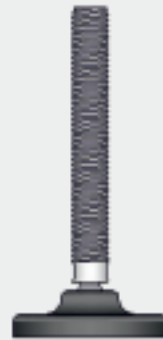

### Adjustable Foot

### Fitting and adjustment

The M30 adjustable foot with swivel base, is screwed into adjustable foot mounting plate.  
The mild steel mounting plate with adjustable foot housing, is fixed to the underside of the planter base.  
A M30 hex full nut is welded to the underside of the mounting plate.  
The adjustable foot is adjusted with a 26mm wrench.

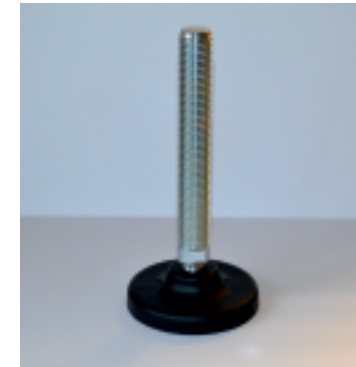

### Base diameter

M30 adjustable foot with swivel base.  
The base diameter is 122mm.

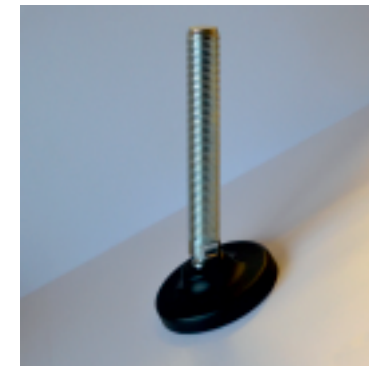

### Swivel base

The swivel base can adjust to allow for sloping ground with a fall of up to 1 in 2.06 (26°).



### Bolt down base

For extra security, it is possible to drill and bolt through the base of the adjustable feet.

# STOCKPORT planter

## MATERIAL FINISHES

### Street Design Limited

Unit 35  
Hayhill Industrial Estate  
Barrow upon Soar  
Leicestershire LE12 8LD

Contact us:  
Telephone: 01509 815335  
Fax: 01509 815332  
Email: [sdl@street-design.com](mailto:sdl@street-design.com)  
Web site: [www.street-design.com](http://www.street-design.com)



### Standard finish

#### FSC certified treated redwood standard finish

As standard, all FSC treated redwood planters will be supplied with a natural finish. The preservative treatment process will colour the timber a light brown/green.



#### Stainless steel standard finish

After fabrication, the 60.3mm diameter top and bottom rails will be dull polished. The stainless steel rails will require no further maintenance.



#### Aged natural treated redwood

Left to weather naturally, the timber will eventually turn a silver grey colour.



### Optional finishes at extra cost

#### FSC certified treated redwood optional finish

As an optional extra, the FSC certified treated redwood can be supplied with a stained finish. This will be applied after the timber treatment process. The standard stain will be 3 coats of Ronseal quick drying water based stain. The standard colour will be teak. Other stains and colours can be applied upon request.



Optional teak stained finish

#### FSC certified iroko hardwood standard finish

As standard, all FSC iroko hardwood planters will be supplied with a natural finish. Due to the nature of the material and the density of the grain, iroko hardwood is not capable of taking a preservative treatment. Iroko hardwood is a naturally durable material, giving a life expectancy in excess of a treated softwood.



#### FSC certified iroko hardwood optional finish

As an optional extra, the FSC certified iroko hardwood planters can be supplied with a stained finish. The standard stain will be 3 coats of Ronseal quick drying water based stain. The standard colour will be teak. Other stains and colours can be applied upon request.



Optional teak stained finish

#### Aged natural iroko hardwood

Left to weather naturally, the timber will eventually turn a silver grey colour.



#### Mild steel standard finish

After fabrication, the 60.3mm diameter top and bottom rails will be hot dip galvanised. The galvanised rails will require no further maintenance.



#### Mild steel optional finish

After fabrication and hot dip galvanising, the 60.3mm diameter top and bottom rails can be polyester powder coated. They can be powder coated to any RAL colour depending on product quantity and stock levels of powder colours. Depending on stock levels the powders are available in 3 gloss levels; gloss, satin and matt.



Optional polyester powder coated finish

# STOCKPORT planter

## MATERIAL SPECIFICATION

### Standard planter

#### Uprights and cross brace straps

50x10mm mild steel flat.

#### Base frame

75x50x3mm mild steel RHS and 75x50x6mm mild steel angle.

#### Planter feet

48.3mm Ø mild steel CHS with welded 88.9mm Ø base plate.

#### Horizontal flats

25x5mm mild steel flat.

#### Vertical slats

FSC 95x45mm FIN PAR Wolmanit CX treated European redwood or FSC 95x45mm FIN PAR iroko hardwood.

#### Tubular metal top and bottom rails

Either 60.3mm Ø mild steel CHS or 60.3mm Ø grade 304 stainless steel CHS.

#### Base floor

18mm FSC Eucalyptus treated plywood.

#### Internal lining

Geotextile membrane.

#### Fixing bolts

M10x65mm coach bolts with a BZP finish.

### Optional planter accessories

#### Adjustable feet

M30 adjustable feet with swivel base. See Adjustable Foot page for full details.

#### Tree anchors

25x5mm mild steel flat, hot dip galvanised.

#### Watering system

Choose either the Street Design reservoir system or the Mona tank system. See Watering System page for full details.

#### Planter benches

FSC bench slats to match planter material in either FSC treated European redwood or iroko hardwood, bolted to hot dip galvanised mild steel bench brackets.

### Street Design Limited

Unit 35  
Hayhill Industrial Estate  
Barrow upon Soar  
Leicestershire LE12 8LD

Contact us:  
Telephone: 01509 815335  
Fax: 01509 815332  
Email: [sdl@street-design.com](mailto:sdl@street-design.com)  
Web site: [www.street-design.com](http://www.street-design.com)



### Optional planter accessories continued

#### Base skirting

12mm thick Marine grade plywood boards, screw fixed to blocks fixed to the underside of the planter.

#### Pergola structures

Pergola structures can be manufactured as an integral part of the planter construction. The steel uprights can be extended to carry the upper horizontal 145x45mm section timber bearers and cross bearers.

#### Trellis panels

Trellis panels can be manufactured as an integral part of the planter construction. The steel uprights can be extended to carry the horizontal and vertical trellis timber slats.

#### Inner tower planters

Stockport planters can be supplied with co-ordinating inner tower planters to create feature planting or tiered planting.

#### LED lighting

#### Material samples

Material samples are available on request.

### Guarantee

All planters are guaranteed for 15 years minimum. This guarantee is a minimum and is dependant on the product not being misused or abused. All the materials, treatments and construction will allow for a life expectancy considerably longer than this.

### General specification

#### Construction

All Street Design products are designed and manufactured using only quality, durable materials, construction details and fixings, to provide a long-lasting, durable life expectancy.

#### Assembly

Stockport planters up to 2.8 x 2.8m will be delivered to site fully assembled for off loading and positioning on site. Planters larger than 2.8m will be supplied in sections for bolting together on site.

#### Timber policy

All treated softwood products are manufactured using materials obtained from growers who operate under the Forest Stewardship Council (FSC).

All iroko hardwood products are manufactured using materials obtained from growers who operate under the Forest Stewardship Council (FSC).

#### Materials

Hardwood products are constructed using FSC iroko hardwood, from sustainable sources. Softwood products are constructed using FSC European redwood that has been Wolmanit CX treated, for a desired service life of 30 years minimum.

All mild steel fabricated components will be hot dip galvanised after fabrication to BS EN ISO 1461:2009.

All stainless steel fabricated components will be grade 304. Grade 316 can be specified if the location or project requires it.

All mild steel fixings will be bright zinc plated, and all stainless steel fixings will be A2 (grade 304). A4 (grade 316) can be specified if the location or project requires it.

Planters will be fitted with a geotextile filter fabric lining, which allows the water to drain through the planter, while retaining the fill material.

#### Finishes

FSC treated softwood and iroko hardwood will be left natural to reduce the need for re-staining and help reduce maintenance costs. If required, timber planters can be supplied with a stained finish using 3 coats of quick drying water based wood stain, to the colour of your choice.

Mild steel components will be left with a galvanised finish only. If required, after hot dip galvanising, the mild steel components can be polyester powder coated, to the colour of your choice. The galvanised parts are prepped, treated and sprayed with the polyester powder, before being baked in an oven.

Stainless steel components will have a dull polished finish. If required, the stainless steel components can be supplied with a mirror polished or bead blasted finish.



# STOCKPORT planter

## CARE & MAINTENANCE

**Street Design Limited**  
Unit 35 Hayhill Industrial Estate  
Barrow upon Soar  
Leicestershire LE12 8LD

Contact us:  
Telephone: 01509 815335  
Fax: 01509 815332  
Email: [sdl@street-design.com](mailto:sdl@street-design.com)  
Web site: [www.street-design.com](http://www.street-design.com)



### General

All Stockport planter products are manufactured using quality materials, treatments and finishes. The timber slats are manufactured from either FSC treated redwood or FSC iroko hardwood. The mild steel will be hot dip galvanised after fabrication. The stainless steel will be supplied with a dull polished (brushed) finish. All products require a varied amount of maintenance, depending on the environment, usage and weather conditions. Natural timber, galvanised steel and stainless steel will only require cleaning. In time, stained timber will require re-coating.

#### Maintaining the standard FSC treated redwood finish

Natural finish treated redwood can be washed down with a mild detergent. More stubborn surface marks can be removed with a light, hand sand with a 120 grit, or higher grade sandpaper. Excessive sanding should be avoided.



#### Maintaining the optional FSC treated redwood finish

Stained, treated redwood will need to be re-coated after a period of time. The stain can either start to fade, become dull (oxidised) or incur some surface break up. Lightly sand down the timber using a 120 grit, or higher grade sandpaper. We recommend that the timber is re-stained with the original stain colour and manufacturer. Details can be obtained from Street design Limited. Apply the stain evenly, with brush strokes running parallel with the woodgrain, in thin layers, building up the finish as recommended by the stain manufacturer.

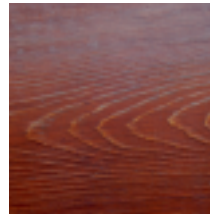

#### Maintaining the standard FSC iroko hardwood finish

Natural finish iroko hardwood can be washed down with a mild detergent. More stubborn surface marks can be removed with a light, hand sand with a 120 grit, or higher grade sandpaper. Excessive sanding should be avoided.

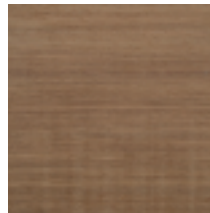

#### Maintaining the optional FSC iroko hardwood finish

Stained, iroko hardwood will need to be re-coated after a period of time. The stain can either start to fade, become dull (oxidised) or incur some surface break up. Lightly sand down the timber using a 120 grit, or higher grade sandpaper. We recommend that the timber is re-stained with the original stain colour and manufacturer. Details can be obtained from Street design Limited. Apply the stain evenly, with brush strokes running parallel with the woodgrain, in thin layers, building up the finish as recommended by the stain manufacturer.

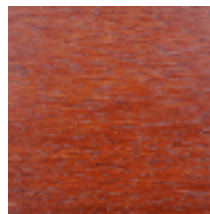

#### Maintaining the standard mild steel finish

Hot dip galvanised mild steel is a very durable and hard wearing finish. Dirt can be washed off with warm water and a mild detergent. Always use clean water and cleaning cloths to avoid surface contamination. After cleaning, any severe marks can be over painted with a cold galvanised, (zinc rich) aerosol spray.



#### Maintaining the optional mild steel finish

Polyester powder coated finishes should be washed down with clean warm water and a mild detergent. Minor touching up can be done with an aerosol to match the original powder coated colour. Details can be obtained from Street Design Limited. More severe damage can be repaired by sanding down, by manual or mechanical means, beyond the damaged area, sufficiently far as to ensure that any step in the powder coated finish is removed. This will ensure that after re-finishing the repair will be difficult to detect.

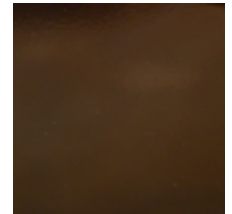

#### Maintaining the standard stainless steel finish

Dull polished (brushed) stainless steel should be washed down with clean, warm water with a mild detergent. More severe marks can be removed by using a fine abrasive, such as a Scotchbrite or stainless steel scouring pad. As dull polishing is a process of applying fine linear scratches evenly over the surface, it is extremely important that rubbing down with an abrasive pad is done carefully in a straight line parallel to the existing grained finish. Rust marks or stains are usually caused by environmental contamination from dissimilar materials laid against, or near to, the stainless steel. These stains can be removed as described above.

