

# Installation Instructions

**1. Attach bongos to wall mount with the M10x50 security screws, square washers and PU mounts. (1.1) (See Assembly Guide)**

**2. Position Bongos in desired location, according to correct Key stage height, this may require 2 persons.**

**3. Mark hole locations (X3) on** Using mount plate as a guide, making sure instrument is level. **Use Template supplied**

**4. Drill hole locations (X3) according to your chosen fixings** (frame fixings, wall bolts or chemical anchors) depending of the structure of the wall.

**5. Fix through Plate (X3) with suitable fixings** (not supplied) in correct orientation and Key stage

Install Instrument with 1m free space (from widest point) around it.

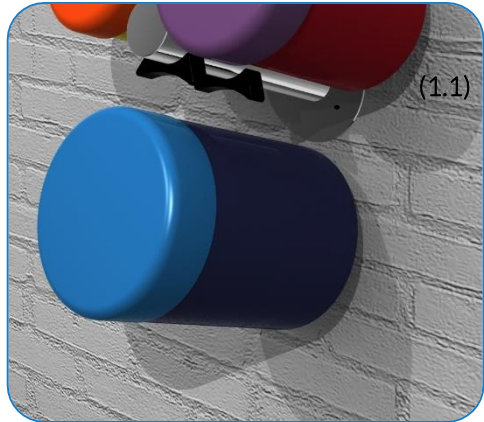
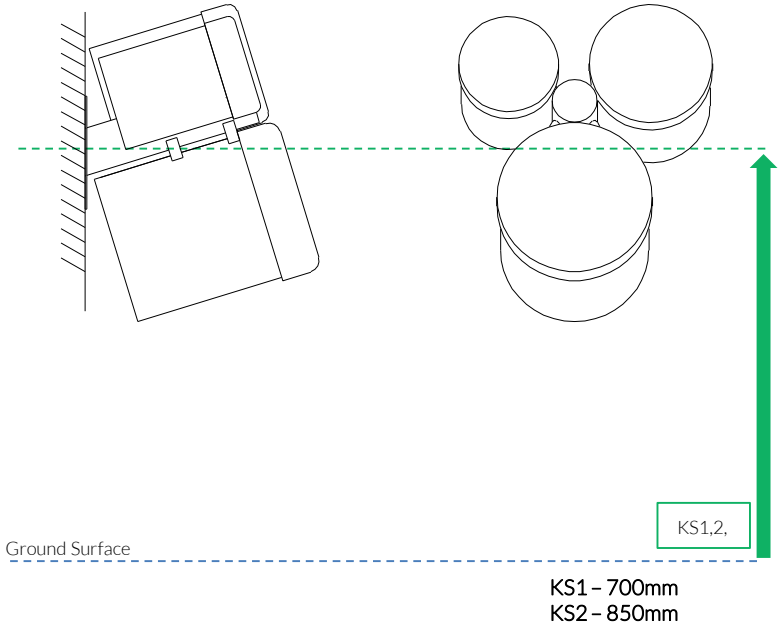
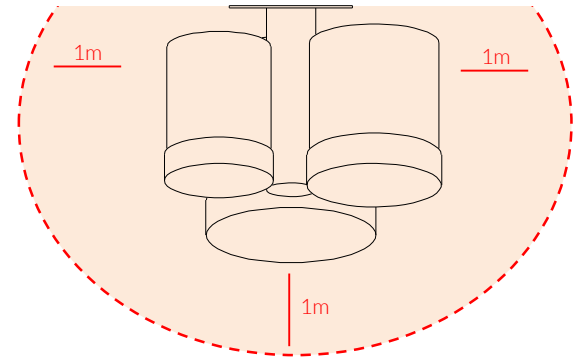





## Wall Mounted

Rainbow Trio Bongos  
1 of 2



### Instrument Components:

-  x6
-  x6
-  x4
-  x2

Metric Conversion:  
700mm/ 28"  
850mm/ 33"  
1m/ 39"

Weight of heaviest part 7 kg (bongos)



Wall Fix Components:

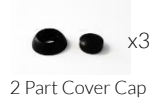

Wall Anchors not supplied

Spares available from [percussionplay.com](http://percussionplay.com) or from your local distributor

7 Kg

Tools:



## Wall Mounted

Rainbow Trio  
Bongos  
2 of 2

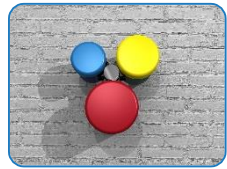

### Instrument Components:



x6

M10x50 Security Screw



x6

M10x50x3 Square washer



x4

PU 200 Mount



x2

PU 250 Mount

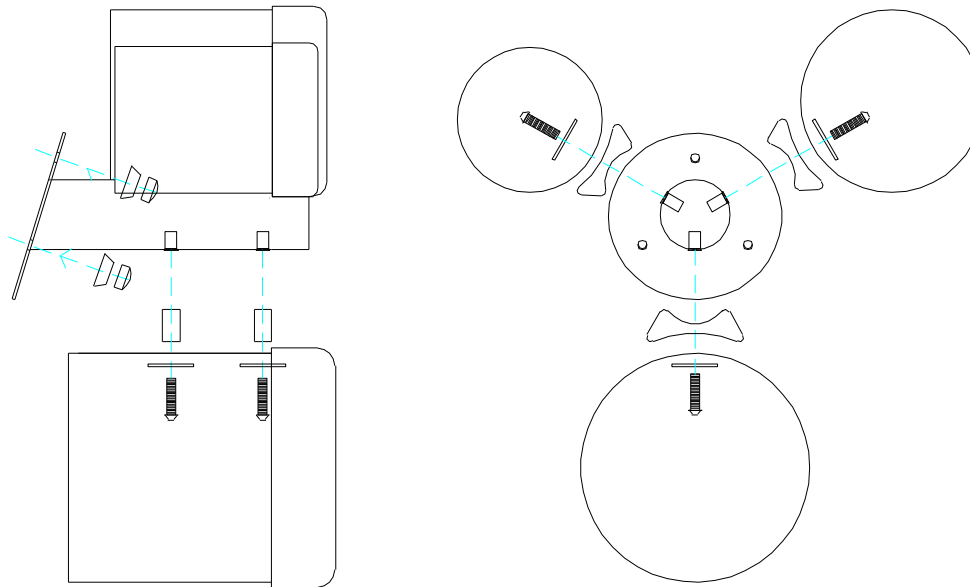

### COMPONENTS LIST:



M10x50 Pin torx X6



M10x50x3 square washer X6



HDPE MOUNT 200 X4

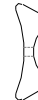

HDPE MOUNT 250 X2



2 Part Cover Cap X3



Played with hands

Wall fixings are not supplied, installer will select suitable method of fixing. Suggested Fixing M8-M10 Rawl Bolt



Spares available from  
[percussionplay.com](http://percussionplay.com) or from your  
local distributor

7 Kg

# Installation Instructions



**1. Position chimes** in desired location, according to correct Key stage height, this may require 2 persons.

**2. Mark hole locations** (X4) on backboard between 1<sup>st</sup> and 2<sup>nd</sup> notes at each end, making sure instrument is level.

**3. Drill hole locations** (X4) according to your chosen fixings (frame fixings, wall bolts or chemical anchors) depending of the structure of the wall.

**4. Fix through Backboards** (X4) with suitable fixings (not supplied) in correct orientation and Key stage

**5. Beaters** can be fixed to Backboards or directly to wall depending on customers preference.

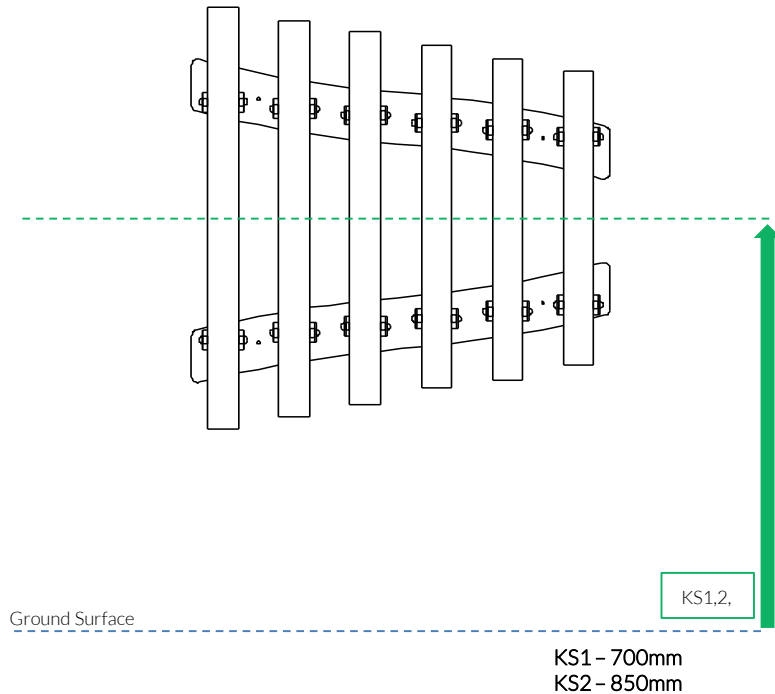
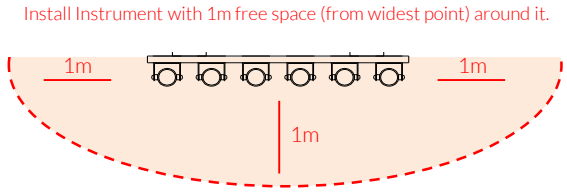

## Wall Fixed

Rainbow Trio Chimes



### Components:



Eye Straps  
X2



Pin Torx 25  
Driver Bit X1



10x38mm  
Secure Screw  
X4

Metric Conversion:  
700mm/ 28"  
850mm/ 33"  
1m/ 39"

Weight of heaviest part **8 kg** (chimes)



Pair Small/Large  
Beaters X1

Wall fixings are not supplied, installer will select suitable method of fixing.

# Installation Instructions



Weight of heaviest part 7kg (Metallophone)

**1. Attach the steel mount to the rear of the instrument with the M8 x20 screws and 2 part security caps. (1.1) (See Assembly Guide)**

**2. Position instrument in desired location, according to correct Key stage height, this may require 2 persons.**

**3. Mark hole locations (X4) using the pre drilled holes in square plate. Use Template Supplied.**

**4. Drill hole locations (X4) according to your chosen fixings (frame fixings, wall bolts or chemical anchors) depending of the structure of the wall. (Not Supplied)**

**5. Fix through Plate with suitable fixings (not supplied) in correct orientation and height for intended Key stage. Cover Fixings with 2 Part Caps supplied**

**6. Attach the 1 pair of beater to the saddle strap on the leg. (1.3)**

Install Instrument with 1m free space (from widest point) around it.

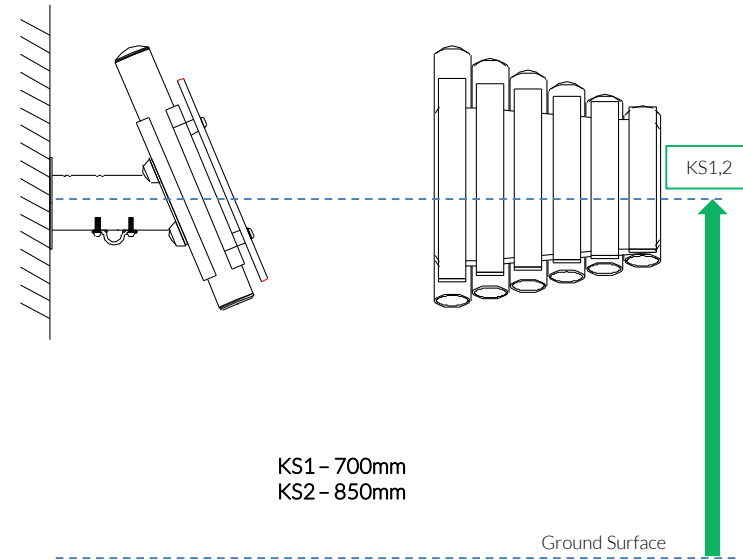
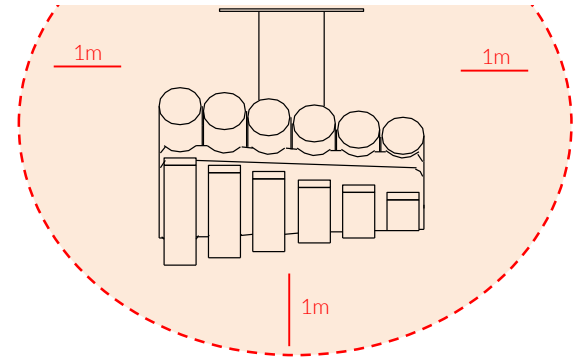

## Wall Fixed Rainbow Trio Metallophone Page 1 of 2



### Instrument Components:

-  x4
- M8x20 Security Screw**
-  x2
- M6x20 Security Screw**
-  x4
- 2 Part Cover Cap**
-  x1
- M6 Saddle Strap**

Metric Conversion:  
700mm/ 28"  
850mm/ 33"  
1m/ 39"



Pair Small Red Beaters X1

### Wall Fix Components:



x4  
2 Part Cover Cap

**Wall Anchors not supplied**

Spares available from  
[percussionplay.com](http://percussionplay.com) or from your  
local distributor

7 Kg

Tools:

 x1
  x1

Wall Fixed  
Rainbow Trio  
Metallophone  
Page 2 of 2





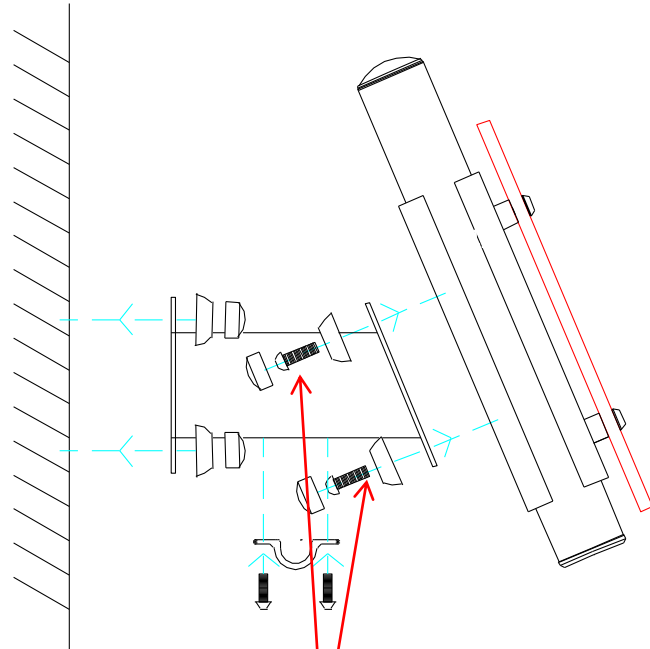

Instrument Components:

-  x4  
M8x20 Security Screw
-  x2  
M6x20 Security Screw
-  x4  
2 Part Cover Cap
-  x1  
M6 Saddle Strap



Thread Lock Solution  
Required (Not Supplied)

## COMPONENTS LIST:

-  2 Part Cover Cap X8
-  M8 Nyloc nut X4
-  Saddle Strap X1
-  M6x20 Pin torx X2
-  M8x20 Pin torx X4

Thread Lock Solution  
Required (Not Supplied)

Pair Small Red Beaters X1

Wall fixings are not supplied, installer will select suitable method of fixing. Suggested Fixing M8-M10 Rawl Bolt



Spares available from [percussionplay.com](http://percussionplay.com) or from your local distributor

7 Kg