

Bancal

Julià Espinàs, Olga Tarrasó
2000

A simple and robust piece designed for places where there are public interrelations. Its versatility enable long rows and seating surfaces to be created, in which formal clarity prevails over any rhetorical aspects.

The structure comprises a bent steel plate supporting a seat composed of FSC-certified tropical hardwood, made of three slats, with or without a single-slat backrest, to which armrests can be attached if required.

Elemento sencillo y robusto diseñado para escenarios de interrelación en espacios públicos. Su versatilidad permite formar amplias alineaciones y superficies de asiento en las que predomina la claridad formal por encima de cualquier aspecto retórico.

Una plancha de acero doblada constituye la estructura que soporta el asiento de madera maciza tropical con Certificado FSC formado por tres listones con o sin respaldo de un solo listón, y en la que se pueden fijar, si se precisan, brazos.





Materials and finishes

Bent 6 mm steel sheet structure with anti-rust protection and powder-painted.

The seat and backrest are made of solid tropical wood slats of 50/65 x 160 mm cross section and variable lengths, FSC-certified and protected with one-coat oil.

Installation

Fixed to the ground by two anti-rust treated anchor bolts on every leg which are placed in holes drilled into the road surface and filled with epoxy resin, quick-setting cement or similar.

The bench is delivered dismantled.

The bench is delivered with the anchor bolts and assembly instructions.

Maintenance

No functional maintenance is required, except to preserve the original colour of the wood.

Weights

(1 module with two structures)

Without backrest: 80 kg.

With backrest: 110 kg.

Materiales y acabados

Estructura de plancha doblada de acero de 6 mm con protección antioxidante y pintada en polvo.

Asiento y respaldo de listones de madera tropical maciza de 50/65 x 160 mm de sección y longitudes variables, con Certificado FSC, protegida con aceite monocapa.

Instalación

El anclaje se realiza mediante dos pernos de acero por pata tratados con protección antioxidante que se introducen en los orificios previamente realizados en el pavimento y rellenados con resina epoxi, cemento rápido o similar.

El banco se entrega desmontado.

El banco se entrega con los pernos de anclaje y las instrucciones de montaje.

Mantenimiento

No requiere mantenimiento funcional salvo que se desee conservar el color original de la madera.

Pesos

(1 módulo con dos estructuras)

Sin respaldo: 80 kg.

Con respaldo: 110 kg.

Slats

Listones

Tropical wood (FSC) /
Madera tropical (FSC)



Oil / Aceite

Structure

Estructura

Steel / Acero



Painted / Pintado
RAL 9006

Steel / Acero



Painted / Pintado
RAL 7024

FSC Certified tropical wood
Certificado FSC
madera tropical





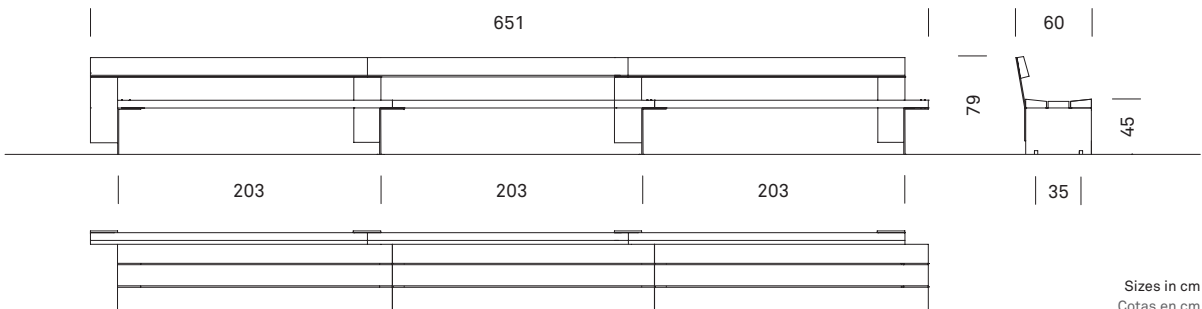
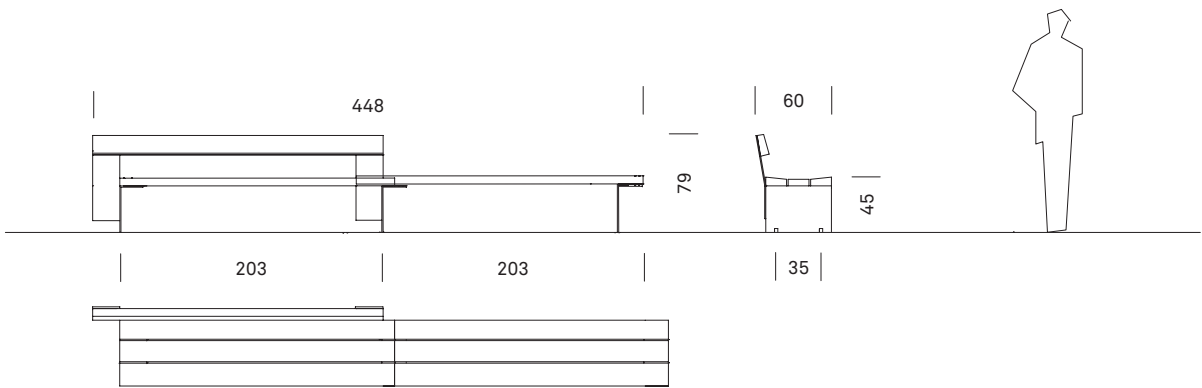
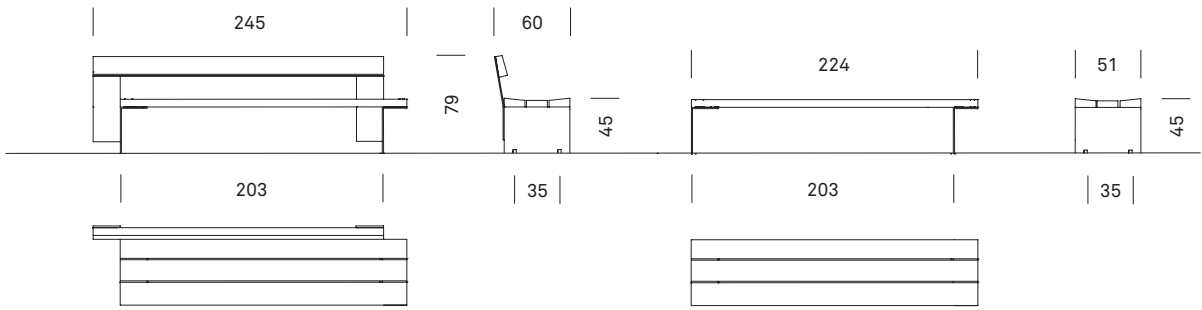

Sizes in cm
Cotas en cm

