



ENERGY SAFE TECHNOLOGIES

Hinged Double-Leaf Doors (HDLD)

OPERATION MANUAL

TABLE OF CONTENTS

1. General information _____	3
2. Purpose and use _____	3
3. Specifications _____	3
4. Technical specifications _____	4
5. Double-leaf hinged doors with attachable door frame _____	5
6. Installation kit _____	8
7. Installation of HDLD doors onto a metal door frame _____	8
8. Installation and connection of the electric heating wire _____	9
9. Adjusting the door fittings _____	11
10. Operation and maintenance instructions _____	13
11. Possible issues and their solutions _____	14
12. Safety measures _____	14
13. Storage and transportation _____	14
14. Disposal _____	14
15. Delivery set _____	15
16. Warranty _____	15
17. Certificate of receipt _____	16
18. Maintenance form _____	17

After having installed the door, it is important to adjust the leaf!

1. GENERAL INFORMATION

This manual outlines information pertaining to ProfHolod refrigeration doors: main uses, information about the doors, technical specifications and installation instructions.

ProfHolod doors are manufactured in full accordance with the drawings and documentation provided by ProfHolod LLC.

All comments and suggestions for improving operations should be sent to: Russian Federation 141000, Moscow Region, Shchelkovo, st. Zavodskaya, 2.

Tel: +7 (495) 240-83-14

e-mail: info@profholod.com

2. PURPOSE AND USE

Doors manufactured by ProfHolod are designed for the thermal insulation of doorways for medium and low temperature refrigeration chambers, refrigerated warehouses and premises requiring sustained high temperatures.

3. SPECIFICATIONS

Type of door	Width of opening (mm.)	Clearance height (mm.)	Thickness of door leaf (mm.)	External material of the door leaf	Internal material of the door leaf	Threshold height (0, 60 or 80 mm)	Temperature range (L or M)	Positioning (R - Right, L - Left)
HDLD	XXXX	XXXX	XXX	XXX-XXX	XXX-XXX	X	X	XX

Materials from which the door is made:

Material code	Description
RAL-0,5	Metal sheet, thickness 0.5 mm, with a RAL polymer coating
Zn-0,5	Galvanized metal sheet, thickness 0.5 mm
AISI 304-0,5	304 food grade stainless steel, thickness 0.5 mm
AISI 430-0,5	430 all purpose stainless steel, thickness 0.5 mm

Table 1 shows the range of sizes for doors on HDLD produced by ProfHolod. Table 1: Range of HDLD door sizes (multiples of 10 mm)

Width of opening	Clearance height	Thickness of leaf
1400...3000	1800...5000	80; 100; 120;

HDLD refrigeration doors are equipped with hardware from Fermod, MTH and Rahrbah.

Doors with a height of more than 2400 mm and a width of more than 2400 mm are fitted only with Rahrbach hardware.

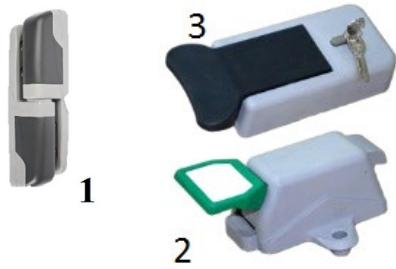

Figure 1.
HDLD fittings:

- 1 - adjustable lifting door hinge, Fermod;
- 2 - internal handle for emergency opening, MTH;
- 3 - external handle with built-in lock, MTH;



Figure 2.
Hardware for HDLD R:

- 1 - adjustable metal door hinge;
- 2 - external rotary handle with built-in lock;
- 3 - internal rotary handle for emergency opening;
- 4 - additional shutter for doors over 2400 mm high

The keys for the door locks are provided by the manufacturer of the locks, ProfHolod cannot be held responsible for the number of unique keys and locks in each order.

4. TECHNICAL SPECIFICATIONS

The door leaf, including the edges, is made from 0.5 mm thick steel sheet, which protects the door leaf from impact. Dow Chemical rigid polyurethane foam is used as a filler.

The foam density is 45-50 kg/m³ and the thermal conductivity is 0.022 W/K·m.

The door leaves are installed with an overlapping door frame. A rubber seal is used to seal the refrigeration door.

For the low-temperature option, the door frames are supplied with an electric heating wire to prevent the sealing profile from freezing. All elements of the door leaf are made without cold bridges to reduce cold leakage.

Table 2.
Specifications of the heating wire

Specifications of the heating wire	Unit	Measurement
Voltage	V	220
Frequency	Hz	50
Diameter	mm	less than 8
Power output	W/m	30 ~ 40

The door leaf is protected from minor damage by a special self-adhesive polyethylene film, which is removed after installation. It is highly recommended to remove the film no more than three months after the door was manufactured.

4. DOUBLE-LEAF HINGED DOORS WITH ATTACHABLE DOOR FRAME

The standard door frame is manufactured from 2 mm cold rolled sheet steel and painted with powder enamel paint in RAL9003 or any other colour from the RAL catalogue. It is possible to manufacture the frame using stainless steel AISI 304 or AISI 430.

The frame is mounted on one side of the opening using a mounting kit (optional) and can be mounted in the following ways:

- On a wall opening made of sandwich panels.
- On a opening in a load-bearing wall, made of concrete or brick
- On metalwork

Figure 3.

Metal door frame for the HDLD. On the left - without a threshold, on the right - with a threshold

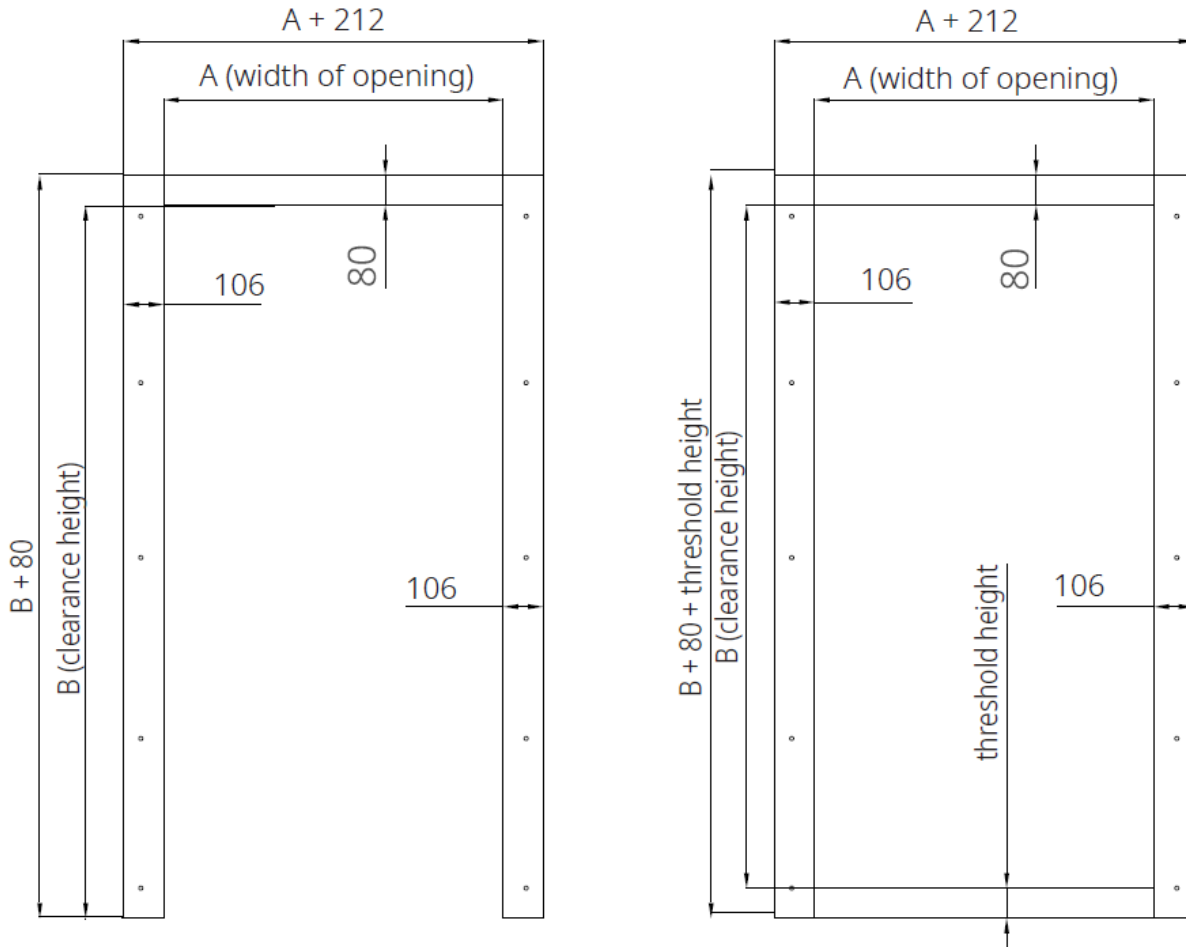

The overall dimensions of the metal door frame depend on the dimensions of the opening:

- Frame width = width of the opening + 212 mm.
- If the clearance height is more than 2800 mm, then the frame width = width of opening + 240 mm.
- Frame height = Clearance height + 80 mm + threshold height.

Figure 4.
 HDLD with a metal door frame. On the left - without a threshold, on the right - with a threshold

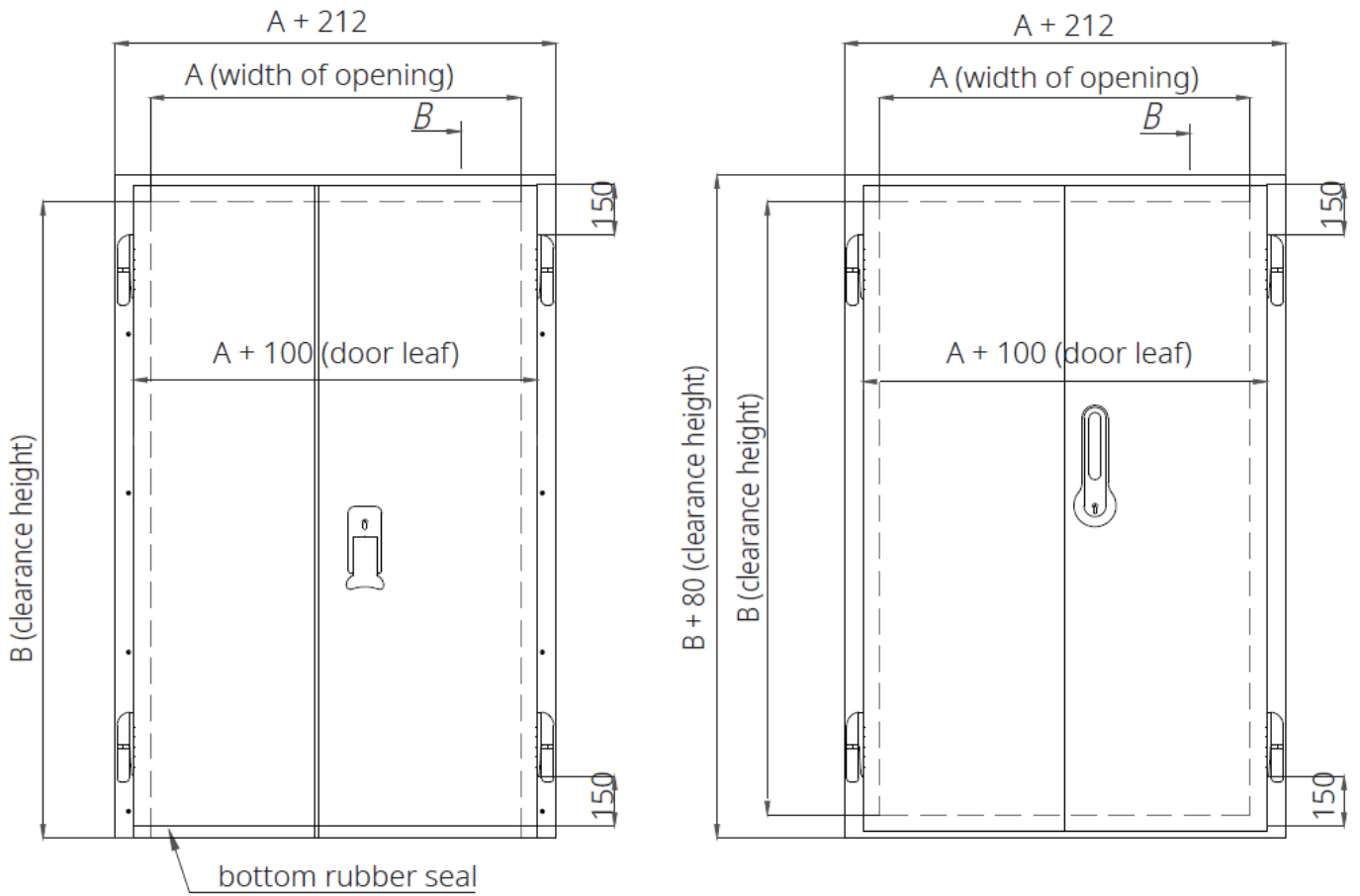

Figure 5.
 Cross-section A-A. On the left, door leaf thickness is 100 or 120; on the right door leaf thickness is 80 mm

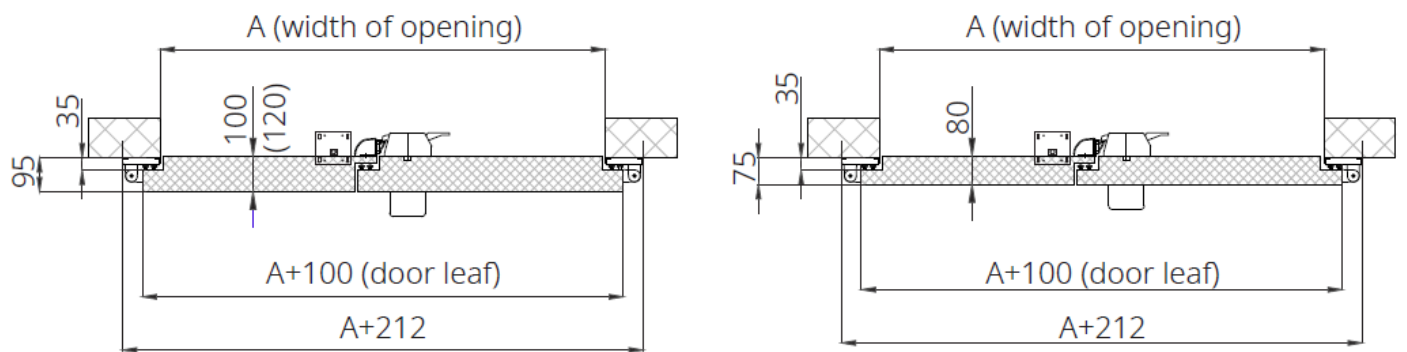
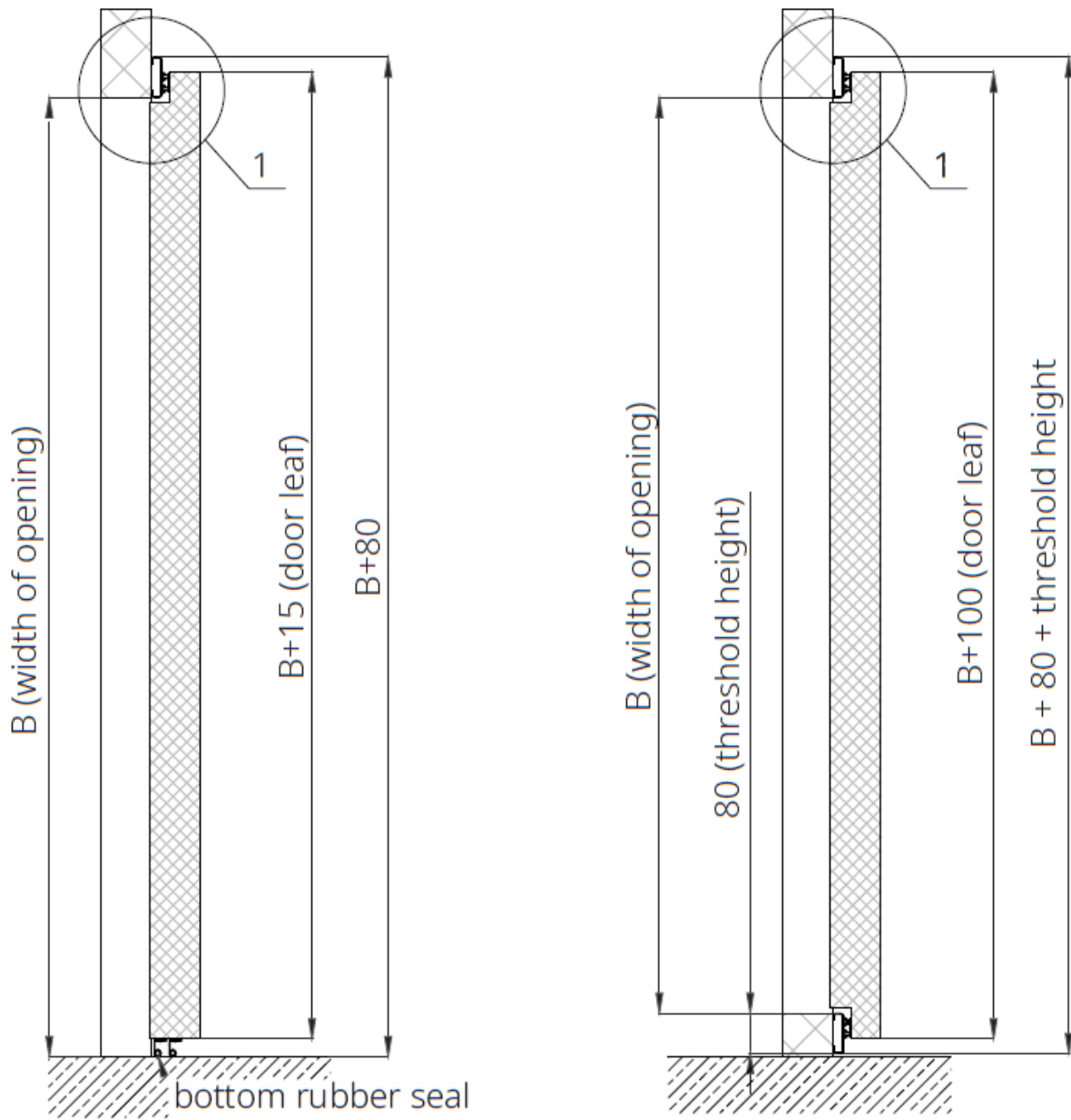

Figure 6.
Cross-section B-B. On the left without a threshold, on the right with a threshold



5. INSTALLATION KIT

The metal frame and the door leaf are attached to the wall using a mounting kit (optional).

HDL D installation:

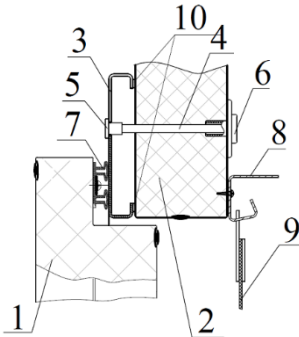

Figure 7.

Assembly unit 1 (cross-section B-B). Fastening the metal overlapping door frame to a sandwich panel.

- 1 - HDLD door leaf
- 2 - Wall sandwich panel
- 3 - Metal frame
- 4 - Threaded rod M8
- 5 - Erickson nut
- 6 - PVC thermal washer with PVC thermal nut
- 7 - Seal
- 8 - Comb for hanging PVC tapes
- 9 - PVC tapes
- 10 - Tape PPE 3x10 to break the cold bridge

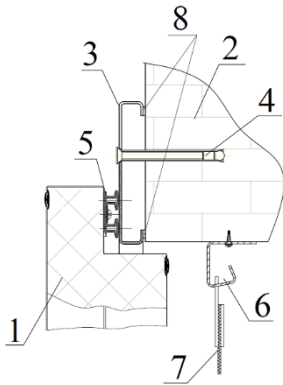

Figure 8.

Assembly unit 2 (cross-section B-B) - Fastening the metal overlapping door frame to a brick wall.

- 1 - HDLD door leaf
- 2 - Concrete or brick wall
- 3 - Metal frame
- 4 - Anchor bolt 10x92
- 5 - Seal
- 6 - Comb for hanging PVC tapes
- 7 - PVC tapes
- 8 - Tape PPE 3x10 to break the cold bridge

6. INSTALLATION OF HDLD DOORS ONTO A METAL DOOR FRAME

The door leaf can only be installed on a prepared (framed) opening. Openings made in sandwich panel walls or brick walls must have a door frame installed before.

- Before installing the doors, make sure that the leaves were not damaged during transportation. Check all parts are accounted for.
- Check the dimensions of the opening against the dimensions indicated in the door specification. Any deviation of the dimensions of the width and height of the opening cannot exceed ± 5 mm. Any diagonal deviation can also only be ± 5 mm.
- Assemble the components of the door frame
- Install the frame into the opening and check both levels: the posts vertically and the cross-beam horizontally.
- Mark the frame mounting holes on the wall.
- Using a drill with a 9mm drill bit, drill holes into the wall of the sandwich panels where the markings are. It is important to ensure the perpendicularity of the holes to the surface of the sandwich panel wall. If fastening the frame to a brick wall, drill holes with a 10 mm drill bit to a depth of 80-100 mm.
- On the reverse side of the leaf, drill a hole of diameter 19-24mm using a drill or "hole saw".

- Around the perimeter of the frame, glue the PPE 3x10 sealing tape to break the cold bridge. The edge of the tape should line up with the inner edge of the frame.
- If necessary, on the reverse side of the frame, at the point where the rubber seal is fitted, fix the wire using adhesive foil.
- Secure the frame to the opening using the appropriate mounting kit.
- Before the final tightening of the fastening nuts, check the level of the frame on both the vertical and horizontal planes
- Hang the leaf on the hinges and tighten the fastening elements.
- Fix the decorative plugs over the holes (fig. 12).
- Check the operation of the lock, the tightness of the door leaf to the frame, and the ease of opening and closing the door. If it does not have a threshold, make sure that there is no gap between the edge of the leaf and the floor.
- Connect the wire to the 220V electrical connection point (if there is a wire).

7. INSTALLATION AND CONNECTION OF THE ELECTRIC HEATING WIRE

Figure 9.

Preparation of a wire segment for connection



It is compulsory to install a wire on doors installed in low-temperature chambers in order to stop the door leaf sticking to the seal.

It is recommended to install a wire to prevent the formation of condensation on the doors of medium-temperature rooms if:

- The environment inside or outside the doors has regular high humidity (rooms with increased sanitation, basements, mushroom growing chamber, etc.)
- An air conditioning unit is/will be located near the doors.
- The room is not ventilated.
- The doors are installed in a dispatch centre. The wire will need to be connected during periods of high humidity.

The door unit uses three electric heating wires::

1. On the inside of the door frame.
2. Inside the rubber seal of the door, where the door leaves meet. Installed at the factory.

3. At the threshold of the doorway.

The preparation and connecting of the 40 W/m metal braid wire should be carried out in the following sequence:

- Cut the braid wire at the required length (no more than 300 mm).
- Pull the cable out of the sheath and twist it into a bundle.
- Remove the rubber insulation.
- Cut off the visible section of the nichrome thread.
- Insulate the cable with PVC tape or heat shrinking tubing at the end of the rubber insulation.
- Strip the ends of the power supply wires.
- Mount the electrical connection box to the wall for the wire. The power supply point for doors with a threshold should be mounted on the upper corner of the door frame on the side with the hinges. For doors without a threshold, it should be mounted on the lower corner on the side with the lock.

Figure 10.

Layout of the wire in the overlapping frame.

On the left - installation in a frame without a threshold; on the right - with a threshold

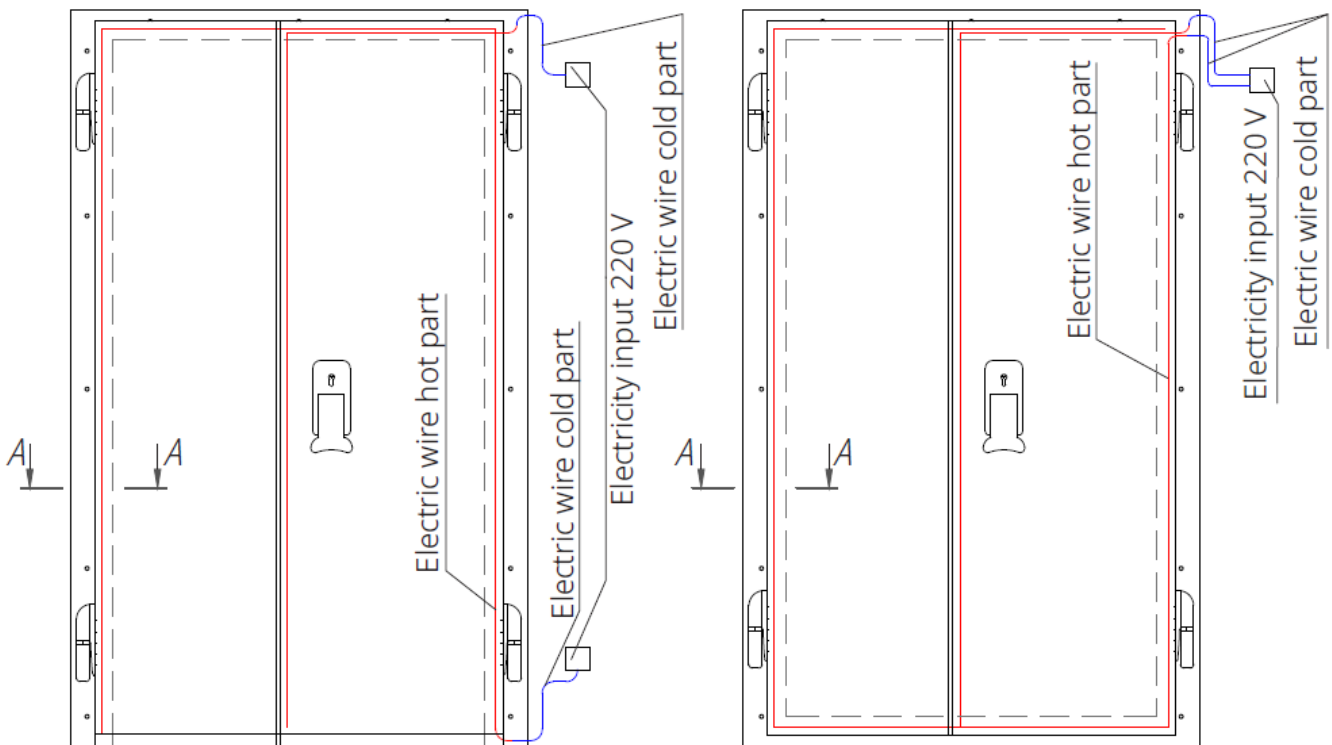

- On the reverse side of the frame, at the point where the seal sits, fix the electric heating wire with adhesive foil tape. The wire should be installed in such a way that the non-heating part, the cold section, is outside the contour of the frame. If the heating part (warm section) is longer than the required circuit, the soldered end of the wire can be wrapped up. The wires can not touch!

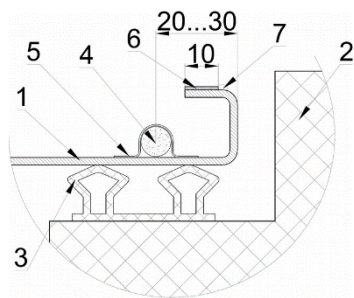

Figure 11.
Assembly unit 3. Wire installation

- 1 - The metal frame
- 2 - Door leaf
- 3 - Double rubber seal (Fermod 67)
- 4 - Wire, metal braid, of constant power 40 W/m
- 5 - Adhesive foil tape
- 6 - PEE 3x10 tape to break the cold bridge
- 7 - Silicone sealant

- The connection is made using a connector block with an AE or VA circuit breaker, with a fuse up to 6 A. Protect the connection point from moisture and dust.

ATTENTION!

The heating element must be wired by a professional electrician.

8. ADJUSTING THE DOOR FITTINGS

HDL D with FERMOD and MTH hardware

Adjusting the position of the side hinges should be carried out in the following order:

1. Remove the covers from the half hinges.
2. Mark, with a pencil, the position of the half loop on the leaf.
3. Remove the sheeting from the hinges.
4. Loosen the 4 screws securing the half-loop onto the leaf.
5. Move the half loop in the desired direction.
6. Tighten the screws.
7. Hang the door leaf, check the pressure of the seal.
8. Replace the half-hinge covers.

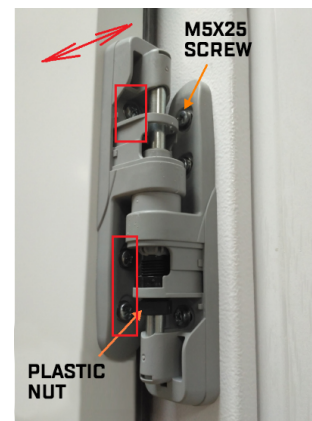

Adjusting the position of the leaf relative to the opening should be carried out in the following order:



1. Remove the covers from the half hinges.
2. Mark, with a pencil, the position of the half loop on the leaf.
3. Remove the sheeting from the hinges.
4. Loosen the 4 screws securing the half-loop onto the leaf.
5. Move the half loop in the desired direction.
6. Tighten the screws.
7. Hang the door leaf, check the position of the leaf relative to the opening.
8. Replace the half-hinge covers.

Adjusting the pressure of the lower seal for doors without a threshold should be carried out in the following order:

1. Remove the covers from the half hinges
2. Remove the sheeting from the hinges.
3. Screw the plastic nut clockwise all the way.
4. Hang the door leaf.
5. Unscrew the plastic nut counterclockwise until there is no gap between the lower seal and the floor. To avoid the door hinge being in the way, it is recommended to carry out the adjustment with the door leaf removed or raised.
6. Replace the half-hinge covers.

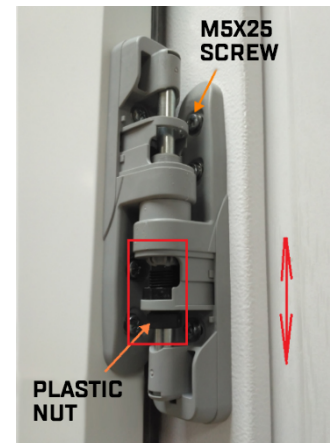

Adjusting the seal pressure from the lock side should be carried out in the following order:



1. Remove the latch cover to be able to unscrew the two M5x25 screws.
2. Loosen the bolt securing the latch.
3. Move the latch in the desired direction.
4. Tighten the latch bolts.
5. Check the amount of pressure of the seal from the lock side, if necessary, make the adjustment again, see paragraphs 2-4.
6. Replace and secure the latch cover.

HDL D with RAHRBACH hardware

Adjusting the position of the side hinges should be carried out in the following order:

1. Remove the covers from the half hinges.
2. Mark, with a pencil, the position of the half loop on the leaf.
3. Remove the sheeting from the hinges.
4. Loosen the 4 screws securing the half-loop onto the leaf.
5. Move the half loop in the desired direction.
6. Tighten the screws.
7. Hang the door leaf, check the pressure of the seal.
8. Replace the half-hinge covers.

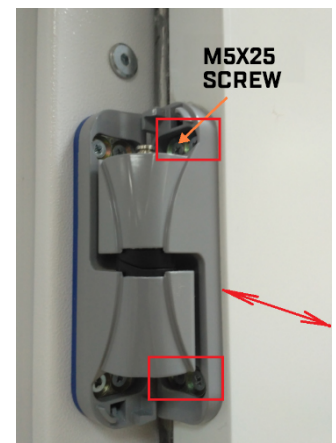

Adjusting the position of the leaf relative to the opening should be carried out in the following order:

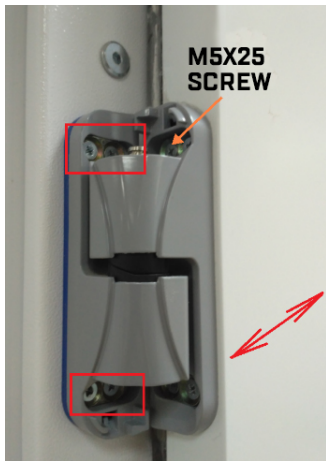

1. Remove the covers from the half hinges.
2. Mark, with a pencil, the position of the half loop on the leaf.
3. Remove the sheeting from the hinges.
4. Loosen the 4 screws securing the half-loop onto the leaf.
5. Move the half loop in the desired direction.
6. Tighten the screws.
7. Hang the door leaf, check the position of the leaf relative to the opening.
8. Replace the half-hinge covers.

• Adjusting the pressure of the lower gasket for non-threshold doors should be carried out in the following sequence:

1. Remove the covers from the half hinges.
2. Turning the adjustment nut with an S = 6 mm hexagon wrench, allowing the required pressure of the bottom seal to the floor to be achieved.
3. Replace the half-hinge covers.



Terms in diagrams:

- M5 x 25 screws
- Latch cover
- Plastic washer

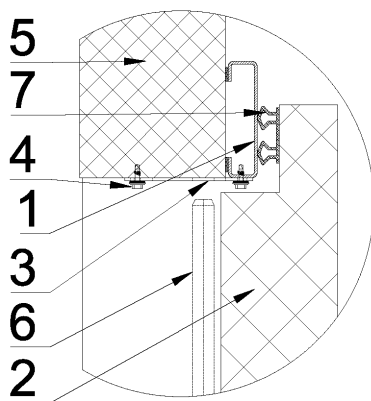

Figure 12.

Assembly Unit. Fastening of the decorative plates to the holes for the upper and lower bolts

- 1 - The frame is metal laid on
- 2 - Door leaf
- 3 - Decorative plate for the bolt holes
- 4 - the Fixing screw
- 5 - Wall
- 6 - Bolts
- 7 - Rubber door gasket

• Adjustment of the pressure of the seal and the decorative plates of the holes of the bolts of the secondary leaf, should be performed in the following sequence:

1. Place the plates into position, using the screws of the adjusting (oval) holes, so that the attachment points are in the wall and on the overhead door frame (Figure 12).
2. Make the final adjustment of the seal pressure.
3. Tighten the screws.
4. Install the plastic plugs in the round holes of the plates

10. OPERATION AND MAINTENANCE INSTRUCTIONS

The effective operation and service life of hinged doors is largely dependent on the quality and regularity of maintenance. For a trouble-free and long-term operation of the fittings, it is recommended to schedule an inspection of the fittings, to tighten the fasteners and lubricate the surfaces that experience friction at least once every two weeks. The frequency of maintenance may vary depending on the frequency of the door opening-closing cycles. The door gasket must be lubricated with silicone grease. Careful operation and timely replacement of damaged elements will guarantee a long-term and trouble-free life cycle.

It is compulsory to install a canopy to protect from the sun, snow and rain if the door is installed outside. Storage, installation and operation of doors under the influence of direct sunlight on the door leaf is strongly not recommended.

11. POSSIBLE ISSUES AND THEIR SOLUTIONS

Possible malfunction	Likely cause	Recommended course of action
Occurrence of noise when in use (squeaks etc.)	Lack of lubrication	Lubricate the support bearings of the hinges, the hinges themselves and/or the door locks.
Failure of locks, handles or latches	Damage during use	Replace damaged items

12. SAFETY MEASURES

Before starting work, it is important to inspect the general condition of the doors. Do not use the doors if there are any issues or malfunction of parts.

Carry out regular maintenance and inspections, including regular inspections of the power supply to the door block.

13. STORAGE AND TRANSPORTATION

The transportation of doors must be in their original factory packaging, to ensure the protection of the doors from any damage. During transportation the door sets must be securely fastened in a stable position to prevent from any shifting or movement. The doors can be transported by any means of transport, provided they can be securely fastened. Keep the door leaves from any shocks or impact loading and unloading. The door blocks should not be exposed to direct sunlight. Storage and operation of doors in direct sunlight is also prohibited. Doors should be stored in spaces protected from precipitation and in a position that does not add any load stress onto the fittings. No more than six doors, with foam pads, are allowed to be stored horizontally. Packaged products can get more heavy over time: they can absorb moisture, condensation, etc.

14. DISPOSAL

At the end of its service life, the disposal of heat-insulating material or polyurethane foam by incineration is **STRICTLY FORBIDDEN**.

15. DELIVERY SET

1. Metal door frame
2. Door leaf, of the correct size for the opening.

The standard delivery set of the door includes:

1. Door leaf, sized to the dimensions of the opening, made of 0.5 mm thick galvanized metal, with

an RAL polymer coating. (see Table 1)

2. Metal door frame made of 2 mm thick cold-rolled sheet steel, painted with RAL powder enamel paint.

Possible additions or adjustments:

1. Door leaf can be made from AISI 304 or AISI 430 stainless steel.
2. Metal frame can be made from 2 mm thick stainless steel AISI 304 or AISI 430.
3. Wire to heat the gasket on the metal frame.
4. A set of fixing elements, so you can install the frame to a sandwich panel, metal structure or brick wall.
5. Cover caps.

16. WARRANTY

ProfHolod LLC guarantees that the door set will meet the design specifications and operational functionality outlined in the documentation, provided that the consumer observes the recommended rules for transportation, storage, installation and operation.

The warranty period for the door set is 1 year from the date of shipment.

During the warranty period, claims will not be accepted if:

- Instructions for installing or adjusting the door block are violated;
- Parts or assembly units are damaged as a result of errors during installation and operation.

The warranty does not cover

- the gaskets,
- on parts that wear quickly.

The manufacturer reserves the right to make minor design changes to the product that are not reflected in this document.

Detailed instructions for loading and unloading, transportation, storage, installation and operation, as well as technical documentation for products manufactured by ProfHolod LLC are available on our website www.profhod.com.

17. CERTIFICATE OF RECEIPT

Door kit, model _____
corresponds to the ProfHolod documentation and is recognized as serviceable.

The door kit serial number is located at the end of the door leaf in the right corner.

Production date: « _____ » _____ 20 ____

Head of quality control department

Stamp

Date of installation « _____ » _____ 20 ____

18. MAINTENANCE FORM

Date	Maintenance performed (specify the type of work)	Responsible party	Notes

Date	Maintenance performed (specify the type of work)	Responsible party	Notes