

RailSeat ARC

Developed as a way to allow fans to stand safely at domestic club matches and be seated at international and European matches.

The enhanced design of Ferco's RailSeat ARC features a contoured seat for enhanced comfort with a cranked standard, allowing more head room when seated. The RailSeat ARC enables fans to stand safely, whilst having the option to revert to seating when regulations require.

Featuring Ferco's ergonomically designed blow-moulded ARC Lite within a high-strength metal rail – the RailSeat offers a safe way to stand and comfort when seated.

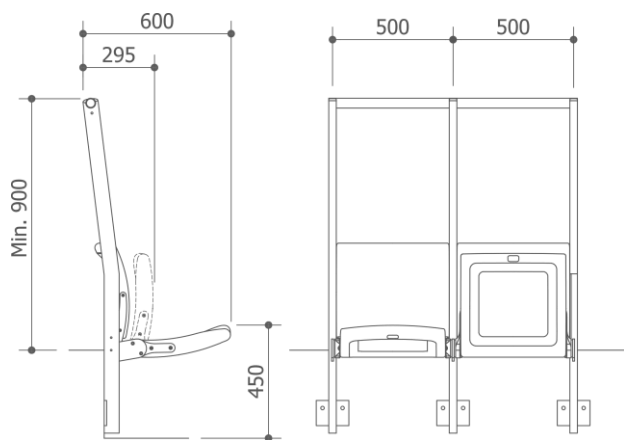

- Variable widths
- RAL matched club colours
- Variable Height
- Floor mounted
- Riser mounted
- Seat numbering

RailSeat ARC

DIMENSIONS

Centre to Centre :	500
Backrest Height :	1175
Closed Depth:	295
Opened Depth:	600
Seat Height: :	450±10

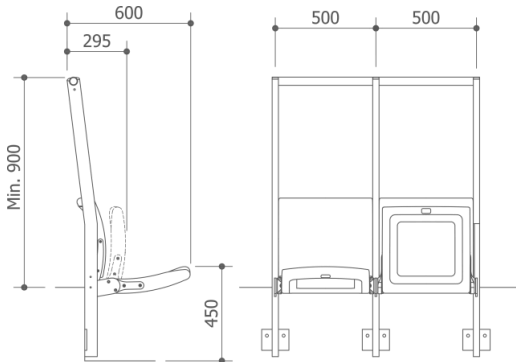

DESCRIPTION & SPECIFICATION

Structure

- The supporting structure is made of mild steel hollow Sections
- The seat and back is attached using steel nuts and bolts for low maintenance and easy removal for replacement of the seat.

Backrest and Seat

- Blow molded co-polymer.
- UV Inhibitors are added at a rate to ensure no significant colour or plastic deterioration.
- Tip-up seat, ergonomically designed seat and a back cushion squab.

Metal / Fabric Finishing

- All metal parts exposed shall be stripped and cleaned with iron phosphate, hot water rinsed and then chromic acid rinsed.
- All metal parts are coated with an epoxy finish of at least 60 microns for indoor use and hot dipped galvanized to BS 729 for outdoor use.
- Conformity with BS-6496 hardness test.

Fire Safety

- Flammability compliance with BS 5852 : 2006 section 3 ignition source 5.