

Bolton Gate Company's Smokebarrier rolling curtains are designed to restrict the lateral spread of smoke and hot gases along the underside of a roof, ceiling or balcony within a building in the event of a fire. They are used as part of a smoke control system to create smoke reservoirs from which smoke and hot gases can be extracted or to stop the spread of smoke allowing valuable time for occupants to escape.

Bolton Gate Company's smoke curtains have been successfully tested to meet the requirements of BS EN 12101-1 (D120) and are supplied with a gravity failsafe system ensuring closure in the event of power failure. They are available in wide spans and can be face fixed, soffit fixed or suspended on rods.



Smoke curtains can be supplied in unlimited widths by use of our overlap system with curtains up to 4.5 metres wide being serviced by single span rollers.

## STANDARD SPECIFICATION

### **Curtain**

Specially coated grey fibreglass material tested to withstand temperatures of 600°C for two hours. The curtain thickness is approximately 0.4mm and the weight 455gms/m<sup>2</sup>.

### **Bottom Rail**

A steel profiled bottom rail is attached to the curtain and is designed to stop at ceiling level or into a recess in the box when raised.

### **Roller**

The curtain coils on to a steel roller mounted on endplate bearings.

### **Box**

The roller and coiled up curtain are housed in a galvanised head box, which is prepared for fixing to the building structure. Single span rollers have a 158 x 150mm box with overlap curtains using a 252mm wide x 150mm high box.

## OPERATION

Smoke curtains are electrically operated by 240 volt AC tubular motors and are supplied with a control panel to be connected (wiring by others) to a normally-closed volt-free contact within the building's fire alarm panel. The standard control panel will operate one motor and a group panel supplied to operate up to ten motors within the same smoke compartment.

This system requires a 240 volt single phase fused spur / three -pin socket (dependant on number of motors) within one metre of the control panel; this supply must be installed prior to us attending the site.

## **Failsafe Operation**

In the event of power failure, the curtains will automatically close by gravity with a controlled descent.

## FINISH

The box and bottom rail are galvanised as standard and can be polyester powder coated at extra cost.

## SIDE GUIDES

The curtain is also available with side guides should there be a requirement that the curtain falls to floor level or where an increased pressure differential is envisaged.

## MAXIMUM SIZES

Unlimited width x 6 metres high.

## WEIGHT

Typically 20kgs per linear metre of width for curtain, box and bottom rail.

## OPTIONS

- Audible and/or visual alarms
- Various fixing arrangements
- Powder coating to box and bottom rail in a range of colours
- Two-stage closing
- Side guides

HEAD DETAILS

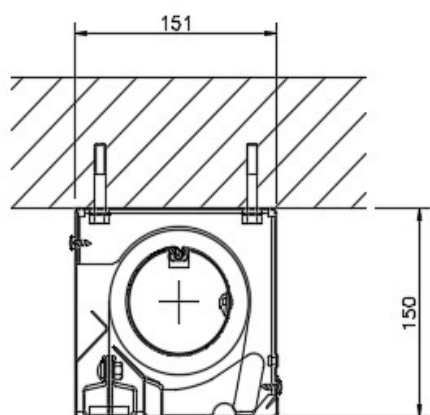

SINGLE CURTAIN  
(UP TO 4500mm WIDE)

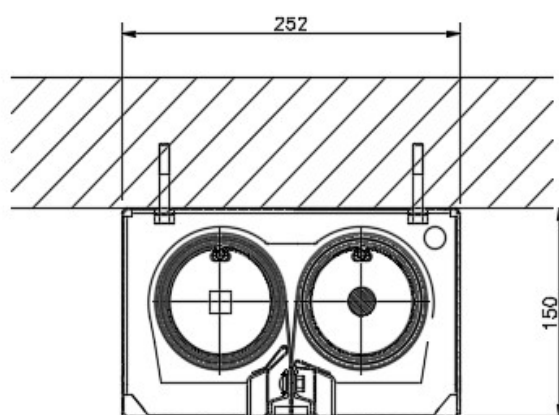

OVERLAP CURTAIN  
(ABOVE 4500mm WIDE)

BOTTOM RAIL

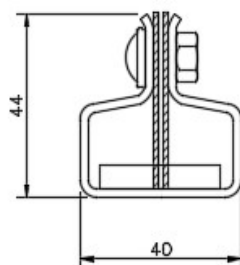

SIDE GUIDE DETAILS  
(IF REQUIRED)

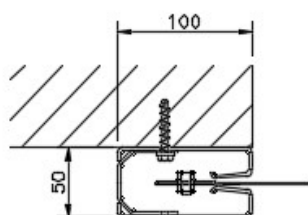

FACE FIXED

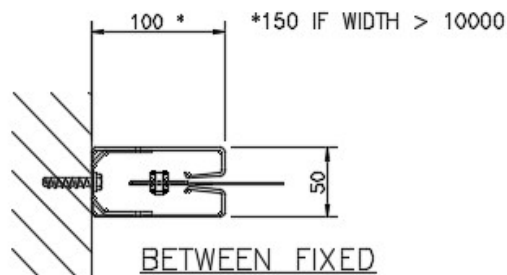

BETWEEN FIXED

ALL DIMENSIONS IN MM