



Sandringham 21 Semi-Countertop Washbasin, 50cm 2 Taphole

Illustrated

- E8959** Sandringham 21 semi-countertop washbasin 50cm, 2 tapholes with overflow and chainstay hole
- B9865** Sandringham 21 Washbasin Pillar Taps
- S8800** Waste, 1 1/4in plastic waste with bead chain and plug, 80mm slotted tail, bolt stay
- S8920** Trap 1 1/4in plastic resealing bottle, 75mm seal

Configuration options

- B9875** Sandringham 21 washbasin pillar taps, crosshead handles
- B9881** Sandringham 21 washbasin pillar taps, lever handles
- S8735** Waste 1 1/4in brass anti theft waste with chain and captive plug, 80mm slotted tail, bolt stay
- S9000** Isovalve servicing valve, inlet and outlet each with compression nut and ring for 15mm copper tube
- S9001** Isovalve servicing valve, outlet with swivel joint for BSP male Connection; inlet with compression nut and ring for 15mm copper tube
- S7435** Nuastyle 1/2in thermostatic blending valve, anti tamper shield, inlets and outlet for 15mm copper
- S8910** Trap 1 1/4in plastic bottle, 75mm seal

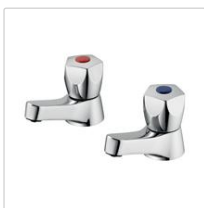
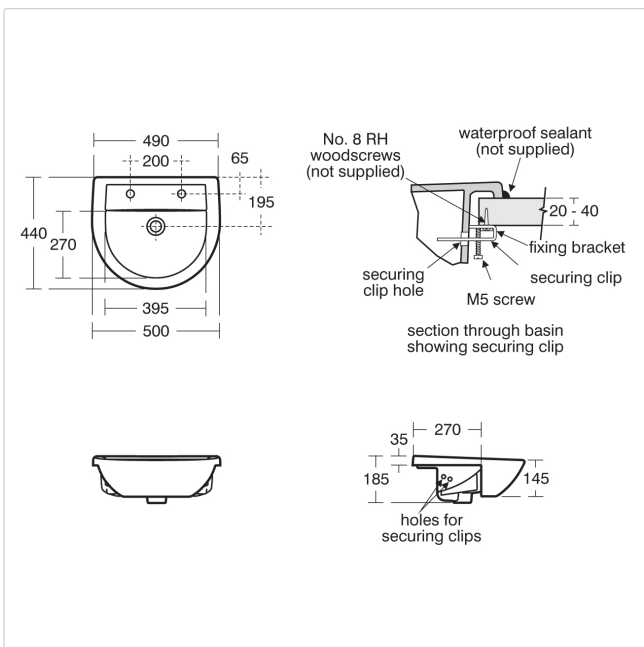

Material

Vitreous China

Weights

- E8959 13.3KG
- B9865 0.970KG
- S8800 0.080KG
- S8920 2KG

Colours

White (01)

Special Notes

Washbasin fixed to countertop with securing clips provided. Joint sealed with waterproof sealant (not supplied).

Frequently used applications

- | | |
|--------------------|----------------|
| Education | Factory |
| Hotels | Office |
| Public Building | Pubs and Clubs |
| Residential | Retail |
| Sports and Leisure | |