

# Sensorflow 21 Tubular 15cm Panel Mounted Spout & Separate Sensor, Mains

## ILLUSTRATED

**A4180** Sensorflow 21 tubular panel mounted 150mm projection spout with anti-splash 3.7 litres per minute aerated outlet, remote panel sensor, copper tube inlets, mains

## ILLUSTRATED PRODUCT DETAILS

### Weights

**A4180** 2.45 KG

### Finishes

**A4180**  Chrome (AA)

### Materials

**A4180** Chrome Plated Brass

### Flow rates

**A4180** 3.7 Litres per minute @ 3 bar pressure

## FINISH OPTIONS



### Special Notes

Minimum operating pressure 0.5 bar. Designed to be supplied with pre-mixed water. Consideration should be given to safe hot water delivery and the use of an appropriate temperature reduction device, please see A5900AA (for use with 15mm pipework) or A5901AA (for use with 22mm pipework).

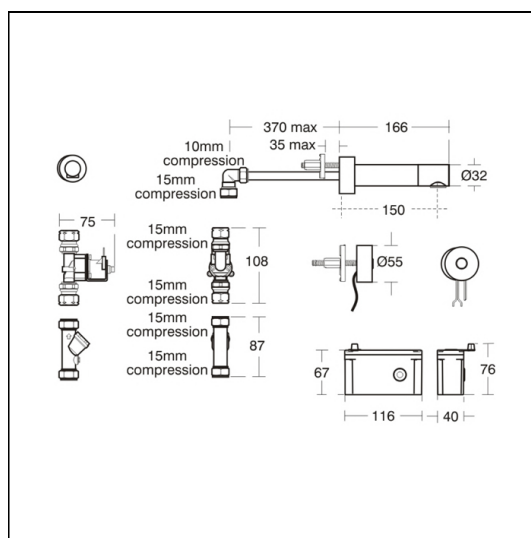

## ACCREDITATIONS

A4180(AA)



1710043

## FEATURES

