

Sensorflow 21 Panel Mounted Cast Spout, Integral Sensor, Link

ILLUSTRATED

A4179 Sensorflow 21 panel mounted 150mm cast spout with integral sensor, flexible inlet tail, solenoid valve, combined servicing valve and filter sensor and solenoid cables and flex connectors, link

ILLUSTRATED PRODUCT DETAILS

Weights

A4179 2.25 KG

Finishes

A4179  Chrome (AA)

Materials

A4179 Chrome Plated Brass

Flow rates

A4179 4.7 Litres per minute @ 3 bar pressure

FINISH OPTIONS



Special Notes

All spouts supplied complete with individual solenoid valve, copper tube inlet and combined servicing valve and filter. Consideration should be given to safe hot water delivery and the use of an appropriate temperature reduction device, please see A5900AA (for use with 15mm pipework) or A5901AA (for use with 22mm pipework). Spouts with integral sensors detect hands within the sensing range and the solenoid valve is opened. Automatically shuts off if sensor is obstructed for a maximum of 50 seconds. Up to 5 link units per main unit or stand alone battery powered units. Regulated flow rate 4.7 litres per minute at 1 bar. Optional low pressure flow guide will deliver 3.3 litres per minute at 0.1 bar.

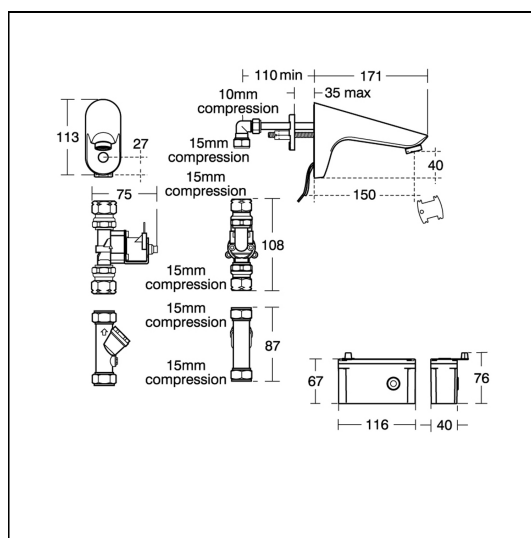

FEATURES

