



Cycle Shelter

data sheet

The Queensbury cycle shelter is a robust shelter that can be supplied in a wide range of sizes, to suit any location.

It has a modular design, which allows multiple shelters to be installed together to house a large number of cycles.

The shelter is manufactured from a zinc protected, steel framework with UV protected PETG glazing, secured in Queensbury's aluminium glazing clamp. This provides a secure, low maintenance shelter.

This shelter can be supplied flat packed, or installed by the Queensbury installation team.

A scooter rack is also available as an accessory or standalone product.



Cycle Shelter
10 cycle capacity



Cycle Shelter
10 cycle capacity with scooter rack



Cycle Shelter
10 cycle capacity



Scooter Rack Accessory
15 scooter capacity



Cycle Shelter
10 cycle capacity with scooter rack

Cycle Shelter

data sheet

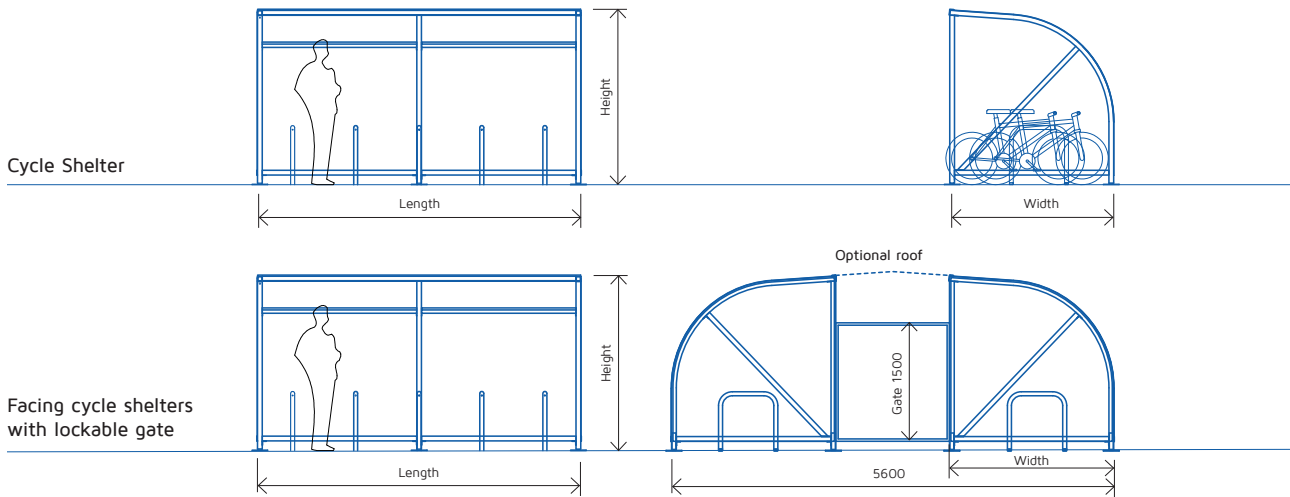

CYCLE SHELTER			
Capacity	Length	Height	Width
6 Cycles	2080mm	2200mm	2080mm
10 Cycles	4100mm	2200mm	2080mm
16 Cycles	6120mm	2200mm	2080mm
20 Cycles	8140mm	2200mm	2080mm

SPECIFICATION

Frame:	Steel - square section
Finish:	Option 1: Zinc protected & powder coated to any standard RAL colour Option 2: Hot dip galvanized
Glazing System:	Extruded aluminium with glazing clamp
Side Glazing:	5mm UV protected clear PETG
Roof Glazing:	4mm UV protected clear PETG
Ground Fixing:	Dig in or Bolt down
Fixings:	Stainless steel
Modular Design:	Yes

OPTIONS

Configurations:	Semi-enclosed and fully secure lockable compounds available
Lighting:	LED mains or solar
Locking Options:	Lockable gates/doors can be supplied with padlocks through to key pads
Scooter Storage:	Scooter rack available
Roof:	Optional on facing cycle shelters

Queensbury Shelters Ltd.
Fitzherbert Road
Farlington Portsmouth
Hampshire PO6 1SE

www.queensburyselters.co.uk
sales@queensburyselters.co.uk
T. 023 9221 0052
F. 023 9221 0059



Cycle Canopy

data sheet

The Queensbury cycle canopy provides a contemporary storage solution for 10 cycles.

The modular design allows multiple shelters to be installed together to house a large number of cycles. The shelter is manufactured from a steel framework with a UV protected polycarbonate glazing, secured in Queensbury's aluminium glazing clamp.

The steel framework is available in two different finishes:

1. Zinc protected and powder coated to match any RAL colour
2. Hot dip galvanized

The canopy is available in two different heights and stainless steel fixings are used throughout.

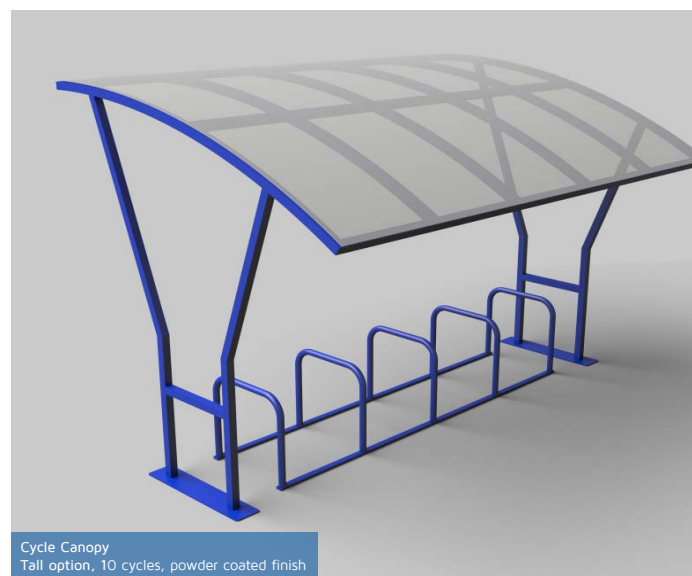

Cycle Canopy

data sheet

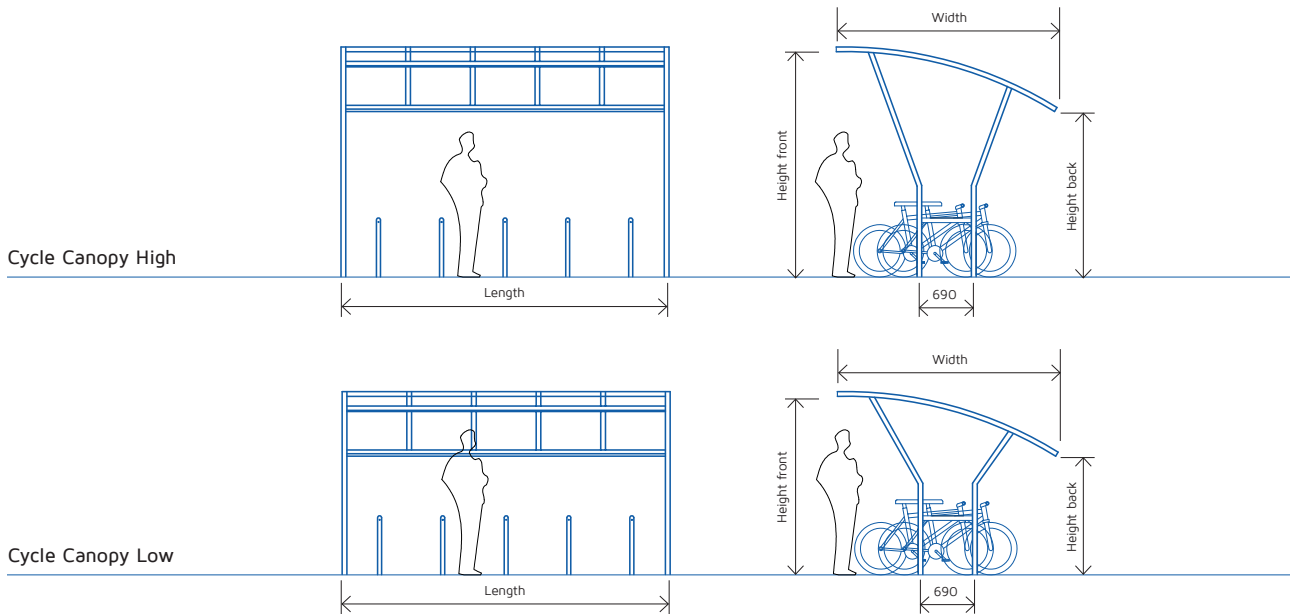

CYCLE CANOPY					
Type	Capacity	Length	Height Front	Height Back	Width
High Canopy	10 Cycles	4160mm	2860mm	2100mm	2800mm
Low Canopy	10 Cycles	4160mm	2260mm	1500mm	2800mm

SPECIFICATION

Frame:	Steel - square section
Finish:	Option 1: Zinc protected & powder coated to any standard RAL colour Option 2: Hot dip galvanized
Glazing System:	Extruded aluminium with glazing clamp
Roof Glazing:	4mm UV protected clear polycarbonate
Ground Fixing:	Dig in or Bolt down
Fixings:	Stainless steel
Modular Design:	Yes

OPTIONS

Lighting:	LED mains or solar
------------------	--------------------

Queensbury Shelters Ltd.
Fitzherbert Road
Farlington Portsmouth
Hampshire PO6 1SE

www.queensburyselters.co.uk
sales@queensburyselters.co.uk
T. 023 9221 0052
F. 023 9221 0059



Scooter Rack

data sheet

The Queensbury scooter rack is available in any size and can be either single or double sided.

The standard configuration is single sided unit that can accommodate 15 scooters. The design is based around a sheffield stand and can be supplied with bolt down or dig in base.

The rack is available in either a galvanized finish or powder coated to match any standard RAL colour.

User provides own lock if required. As an optional extra we can supply security bars and chains, the user would then just provide a padlock.



Scooter Rack
15 scooter capacity



Scooter Rack
15 scooter capacity



Scooter Rack
Security Bar detail



Scooter Rack
Security bar detail



Scooter Rack
Mounted in Cycle Shelter

Scooter Rack

data sheet

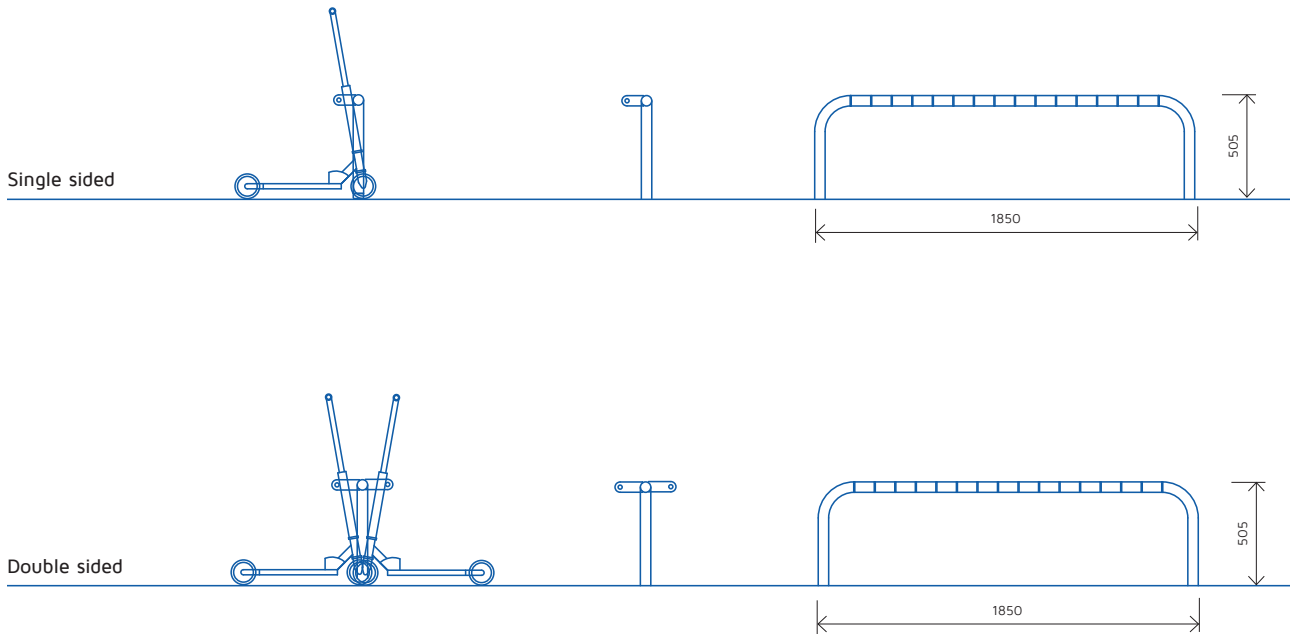

SPECIFICATION

Stand:	Steel tube (50mm diameter)
Finish:	Option 1: Hot dip galvanized Option 2: Powder coated to RAL colour
Ground Fixing:	Dig in or Bolt down
Fixings:	Stainless steel
Modular Design:	Yes
Capacity:	Single sided: 15 scooters total (8 lockable with optional security bar and chain) Double side: 30 scooter total (16 lockable with optional security bar and chain)

OPTIONS

Configurations:	Single sided Double sided
Security:	Security bar and chain

Queensbury Shelters Ltd.
Fitzherbert Road
Farlington Portsmouth
Hampshire PO6 1SE

www.queensburysshelters.co.uk
sales@queensburysshelters.co.uk
T. 023 9221 0052
F. 023 9221 0059



Sheffield Stands

data sheet

The Sheffield cycle stand is the common stand used for cycle parking. Queensbury Shelters can provide various options in the toast rack or single stand style.

The toast rack style has multiple stands welded to two base rails, which is available in 3, 4 or 5 stand variants. The single stand is available in both bolt down and dig in versions, both of these stands are also available in a tapping rail option. If fixing a row of stands the tapping rail stand is recommended for the end stand, so this can be identified by anyone using a cane.

All the stands are available in a standard galvanized finish, powder coated or stainless steel.



Sheffield Stand Toast Rack
10 cycle capacity, galvanized



Sheffield Stand Toast Rack
8 cycle capacity, powder coated



Sheffield Stand Toast Rack
10 cycle capacity, galvanized



Sheffield Stand Toast Rack
8 cycle capacity, powder coated

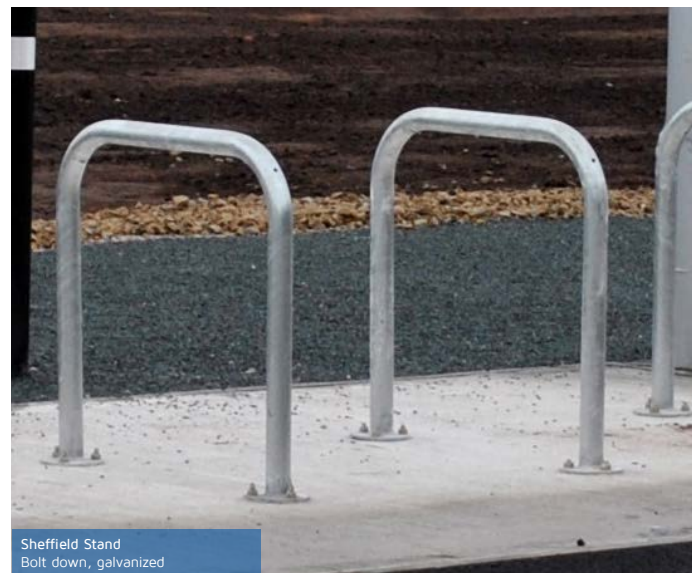

Sheffield Stand
Bolt down, galvanized

Sheffield Stands

data sheet

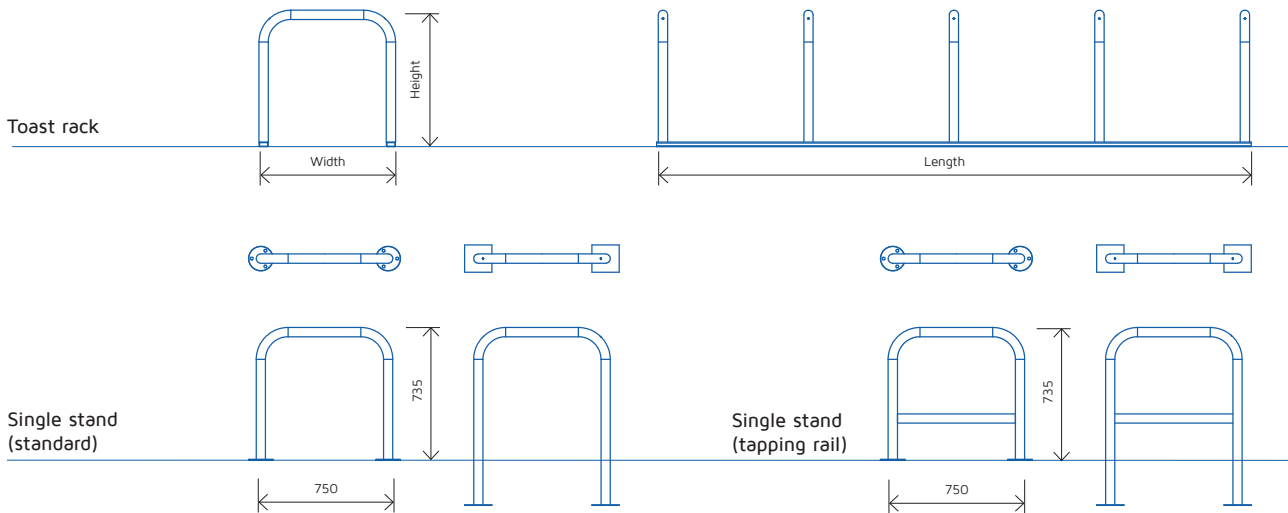

SHEFFIELD STAND Toast Rack			
Capacity	Length	Height	Width
6 Cycles	1670mm	750mm	750mm
8 Cycles	2470mm	750mm	750mm
10 Cycles	3270mm	750mm	750mm

SPECIFICATION

Stand:	Steel tube (50mm diameter)
Finish:	Option 1: Hot dip galvanized Option 2: Powder coated to match RAL colour Option 3: Stainless steel
Ground Fixing:	Dig in or Bolt down
Fixings:	Stainless steel
Modular Design:	Yes

OPTIONS

Configurations:	Toast rack Single stand (standard) Single stand (tapping rail)
------------------------	--

Queensbury Shelters Ltd.
Fitzherbert Road
Farlington Portsmouth
Hampshire PO6 1SE

www.queensburysshelters.co.uk
sales@queensburysshelters.co.uk
T. 023 9221 0052
F. 023 9221 0059





Head Office and Sales
Fitzherbert Road
Farlington
Portsmouth
Hampshire
PO6 1SE

Northern Depot
Unit 9B
Oakwood Trade Park
North Shields
NE29 8SF

T: 023 9221 0052
F: 023 9221 0059

www.queensburyselters.co.uk
sales@queensburyselters.co.uk