



1 x 80 x 80 x 80 cm  
Concrete needed:  
ca. 0.50 m<sup>3</sup>



Total weight:  
ca. 160 kg



ca. 3 P. x ca. 2.0 h



4 - 12 years



1.00 m



EN 1176

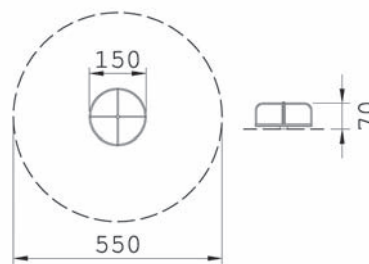

Scale 1:200

Metal parts galvanised or galvanised and painted, floors made of birch plywood 27 mm (screen print) thick, maintenance-free ball bearing.

**Roundabouts**

	galv.	galv. + painted		
Roundabout Ø 2.00 m	9044415200	9044416200		
Miniature roundabout Ø 1.50 m	9044415150	9044416150		

**Roundabouts - Inclusive**

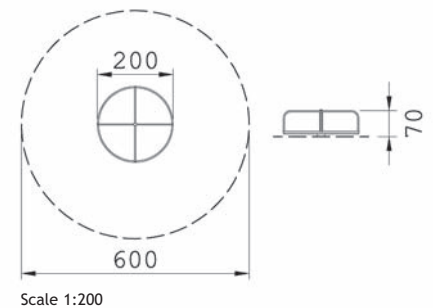

Scale 1:200

Metal parts stainless steel, floor made of corrugated aluminium plate, maintenance-free ball bearing.

**Roundabouts - Inclusive**

Stainless steel roundabout type 1 Ø 1.50 m	9044410150		
Stainless steel roundabout type 1 Ø 2.00 m	9044410200		

► Subject to technical modifications    ► regular maintenance checks