



HADDONSTONE

Balustrading & Parapet Screening





VISIT US

At East Haddon, in the rolling countryside of Northamptonshire in England, Haddonstone has beautiful show gardens and an interior showroom where visitors can see many of the designs illustrated in this catalogue in their proper settings, see opposite. The garden and showroom are open every week from Monday to Friday ~ public holidays and Christmas period excepted ~ between the hours of 9.00 am and 5.00 pm. The gardens are also open on occasional weekends as part of the National Garden Scheme (Yellow Book) to raise money for charity. Brown tourism signs guide visitors to the gardens from the A428.

Haddonstone pieces may also be viewed at stockists across the UK as well as the RHS gardens at Wisley and Harlow Carr. In addition, Haddonstone, TecLite, TecStone and Technistone designs can be seen at Pennine Stone Ltd, Askern Road, Carcroft, Doncaster DN6 8DE. Haddonstone's catalogue can be obtained from the Building Centre, Store Street, London WC1 or viewed online at:

www.haddonstone.com/view-catalogue

In the USA, Haddonstone offices have a permanent showroom display, whilst Haddonstone designs may also be viewed at stores and distributors across North America.

WHY HADDONSTONE?

Haddonstone is a unique form of cast limestone with a surface texture similar to Portland stone. The material matures and weathers like natural stone yet, piece for piece, normally costs significantly less than quarried stone.

The ability to mould the Haddonstone material into almost any shape ~ faithfully reproducing new designs or producing replicas that are virtually indistinguishable from an antique original ~ has won the company numerous contracts ranging from leading international hotels and retail developments to listed National Trust properties and prestige residential projects.

The material used in every design, from the smallest planter to the largest Corinthian column, exceeds the compressive cube strength requirements of the United Kingdom Cast Stone Association and complies with all relevant UK and European standards, whilst TecStone also meets the requirements of all US standards.

Each design is hand made by Haddonstone in the UK or USA using moulds created within the company's extensive mould shops and studios. Using these same facilities Haddonstone can even manufacture non-standard architectural stone pieces to practically any shape, size or colour.

As Haddonstone maintains original models and/or moulds for every single design in the standard collection, and utilises the very latest vapour curing technology, customers can be reassured that the high quality of each stone produced is incredibly consistent whilst retaining the individuality of a hand-made product. The company even offers a five year warranty on cast stone garden ornaments.

Haddonstone can also be an enjoyable investment. At a Sotheby's auction, four Haddonstone Plaited Baskets sold for more than twenty times their current retail value.

Haddonstone ~ one of the few things in life that can grow more beautiful and valuable with the passing of the years.

ARCHITECTURAL STONEMWORK BALUSTRADING

THERE ARE FOUR TYPES OF BALUSTRADING:

The Standard Range

Illustrated on pages 125, 126 and 127, the standard range is available in six styles: Flat, Part-Weathered or Weathered, each available to suit central or side run-in situations, with a choice of standard balusters. If balustrading is to be used as a parapet wall or a raised terrace edge, we have several optional under-copings that can be used below plinth course to increase the height of the balustrade, or to cope a substructure.

The 1100 Balustrade

Shown on page 128, this is a heavier balustrade designed to comply with the Building Regulation height of 1100mm (43⁵/₁₆"") required in certain instances. It comprises a weathered rail, weathered plinth, Georgian-style baluster and rectangular pier.

The Kensington Balustrade (USA only)

Shown on page 128, this is an imposing balustrade of handsome proportions.

It comprises weathered rail, upper and lower plinths, Regency-style K610B square balusters and rectangular piers. The plinth moulding is used to frame the inset panel of the pier shaft.

The Spiral Balustrade

Shown on page 129, the Spiral Balustrade is available only with flat rail, K533G-style baluster, standard style of plinth and optional T920 style of under-coping to the radii and falls indicated.



The Standard Range Style FC: Flat Central Run-in

See page 132 for balusters.

TS Tech Sheet No. B10 & B70

Plans below show Pier Caps.
For component weights see page 131

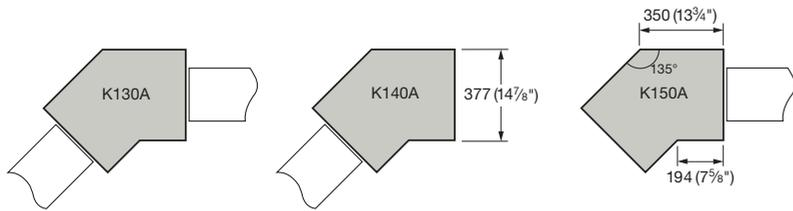

FC style with K533G Balusters/T930 Under Copings

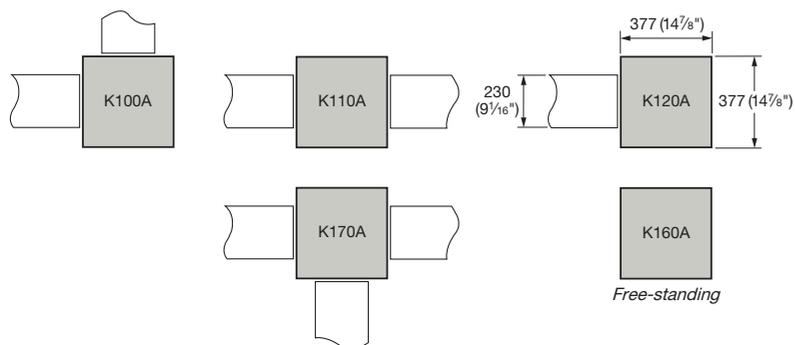
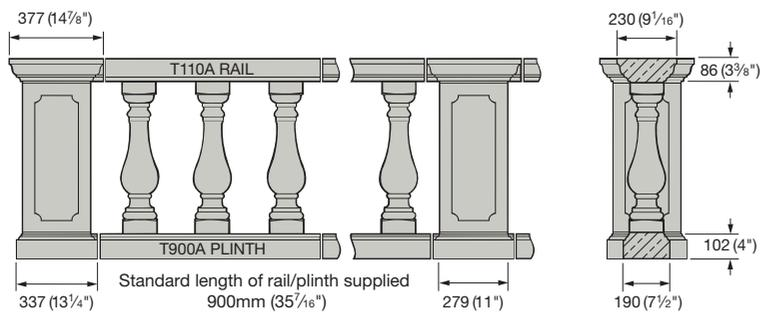

The Standard Range Style FS: Flat Side Run-in

See page 132 for balusters.

TS Tech Sheet No. B15 & B70

Plans below show Pier Caps.
For component weights see page 131.

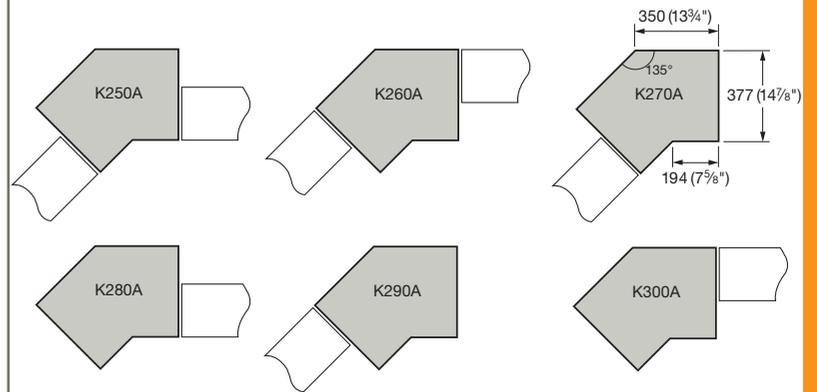

FS style with K533G Balusters/T925 Under Copings

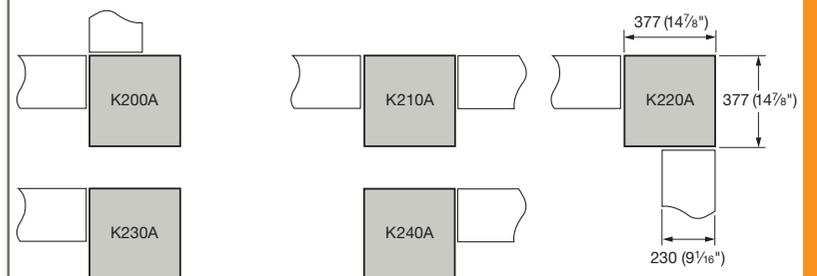
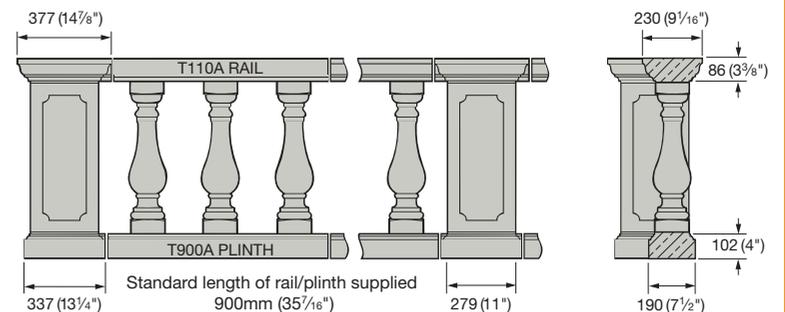

Custom-made products are available on request.

The Standard Range Style PC: Part-Weathered Central Run-in

See page 132 for balusters.

TS Tech Sheet No.B20

Plans below show Pier Caps.
For component weights see page 131.

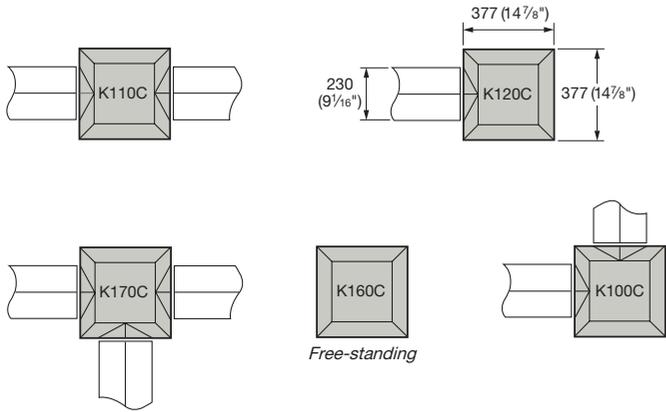

PC style with K457G Balusters / Q560 Plinth (custom piers)

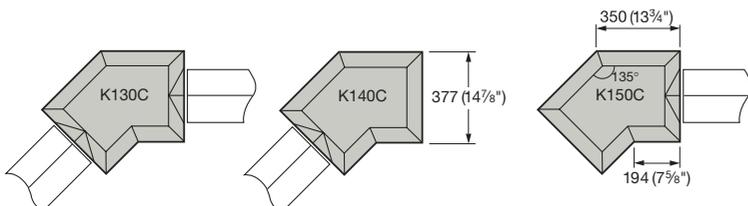
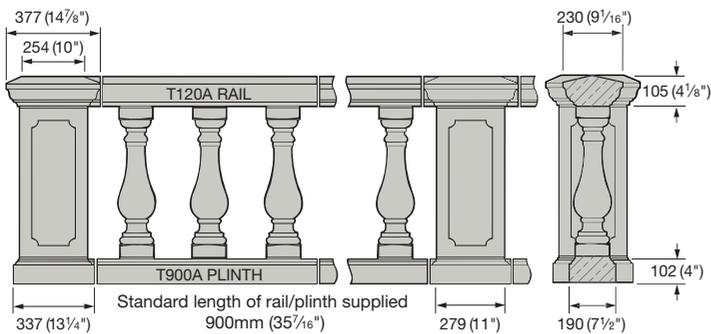

The Standard Range Style PS: Part-Weathered Side Run-in

See page 132 for balusters.

TS Tech Sheet No. B25

Plans below show Pier Caps.
For component weights see page 131.

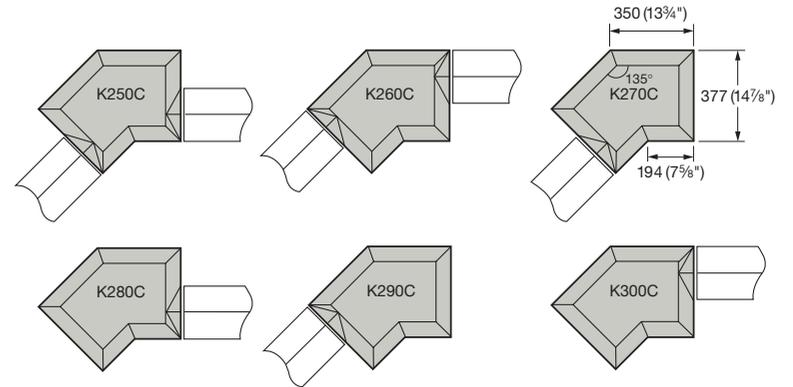

PS style with K533G Balusters

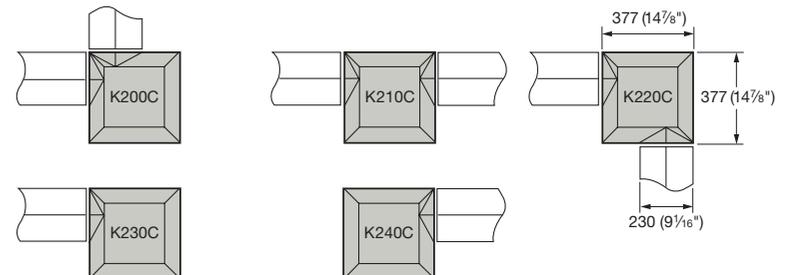
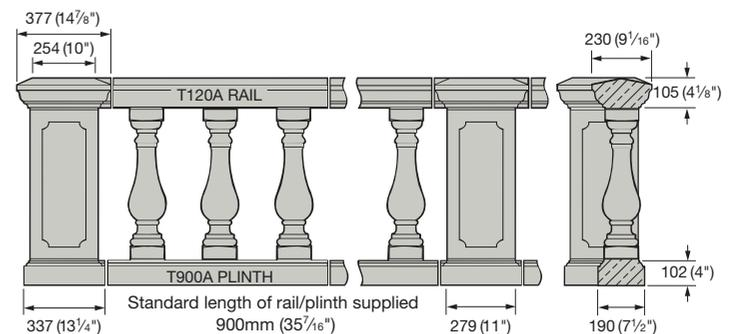

The Standard Range Style WC: Weathered Central Run-in

See page 132 for balusters.

TS Tech Sheet No.B35

Plans below show Pier Caps.
For component weights see page 131.



WC style with K610G Balusters

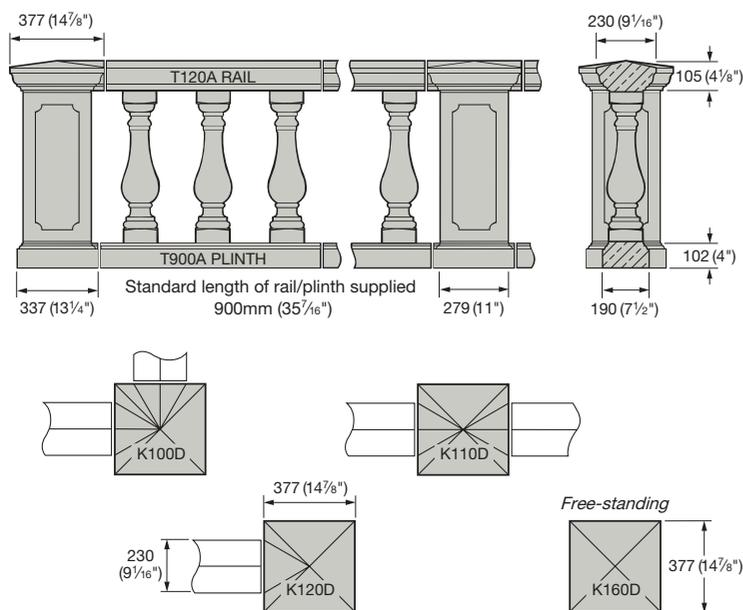

The Standard Range Style WS: Weathered Side Run-in

See page 132 for balusters.

TS Tech Sheet No. B35

Plans below show Pier Caps.
For component weights see page 131.

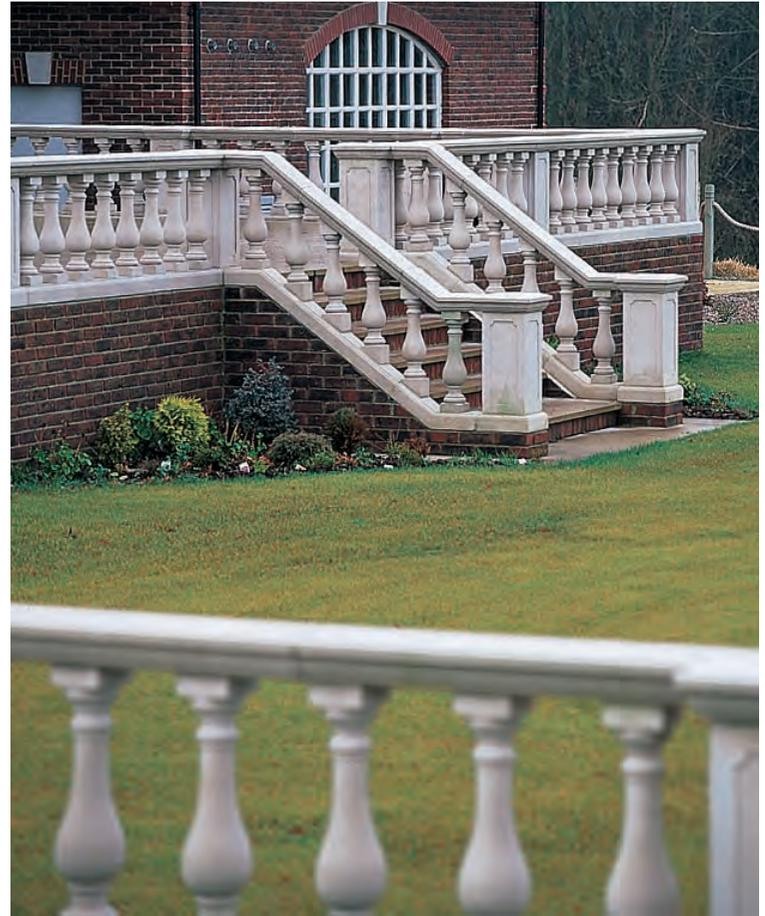

WS style with K533G Balusters

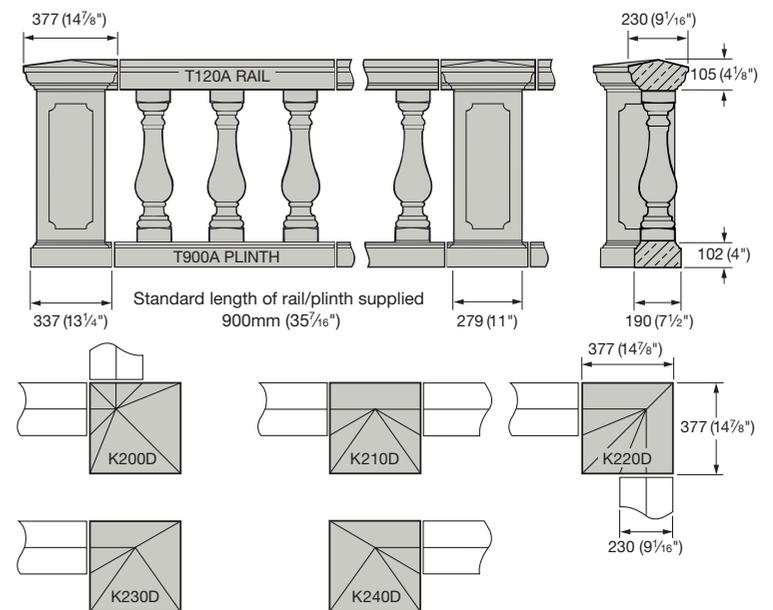

The 1100 Balustrade

The 1100 Balustrade is offered as an alternative to the Standard Range should you require a heavier design of balustrading. It also complies with the Building Regulation height of 1100mm (43⁵/₁₆"), which is required in certain instances, without the need to use additional under-copings or to construct upstands.

TS Tech Sheet No. B40

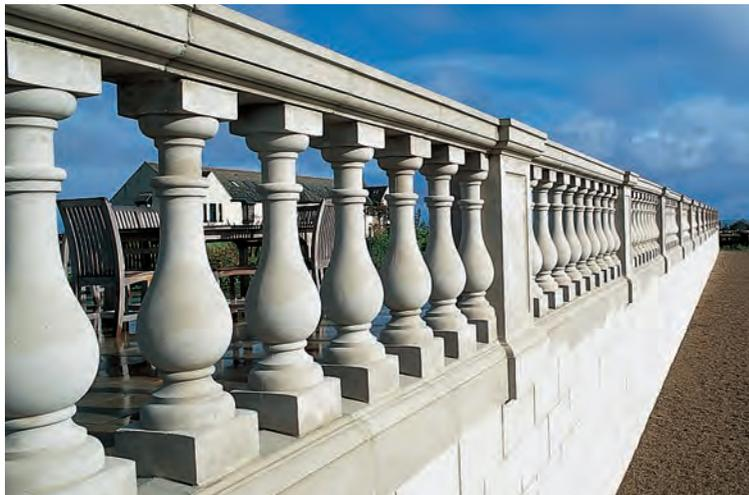
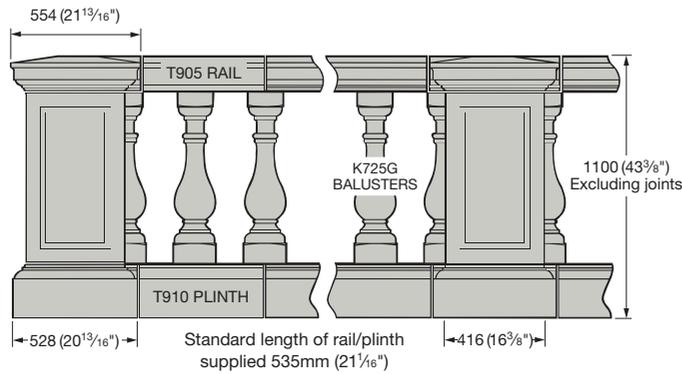

K725G Baluster - 20kg (44 lb)
 Standard Pier (complete) - 212kg (466 lb)
 Corner Pier (complete) - 296kg (651 lb)
 T905 Rail - 67kg/m (45 lb/ft)
 T910 Plinth - 121kg/m (81 lb/ft)

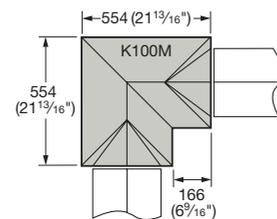
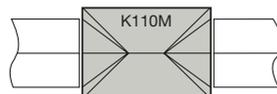
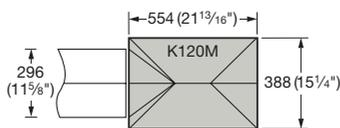
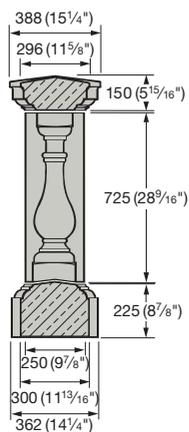

PLANS SHOW PIER CAPS

The Kensington Balustrade (USA only)

The Kensington Balustrade is an imposing balustrade of handsome proportions. It comprises weathered rail, upper and lower plinths, unique K610B square balusters and rectangular piers. The plinth moulding is used to frame the inset panel of the pier shaft.

TS Tech Sheet No. B45

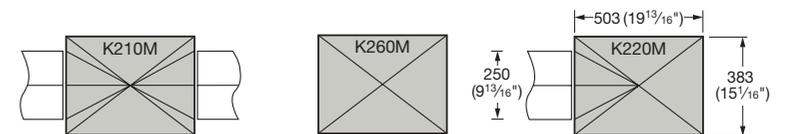
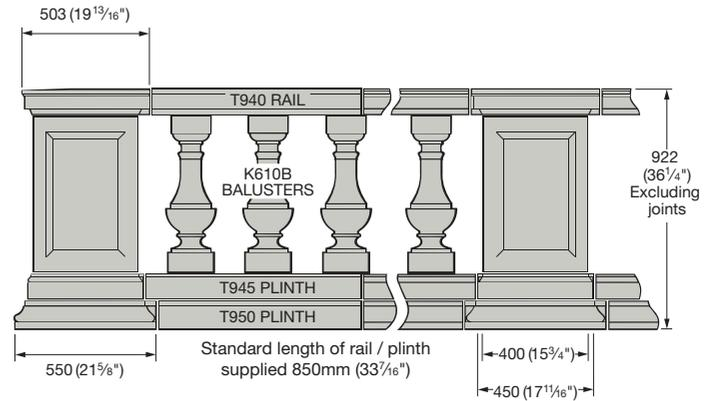

PLANS SHOW PIER CAPS

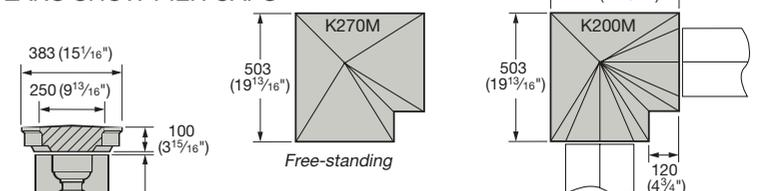

K610B Baluster - 21kg (46 lb)
 K200 Corner Pier (complete) - 300kg (660 lb)
 K210 Intermediate Pier (complete) } 232kg
 K220 Terminal Pier (complete) } (510 lb)
 K260 Freestanding Pier (complete)
 T940 Rail - 37kg/m (25 lb/ft)
 T945 Upper Plinth - 41kg/m (28 lb/ft)
 T950 Lower Plinth - 57kg/m (38 lb/ft)

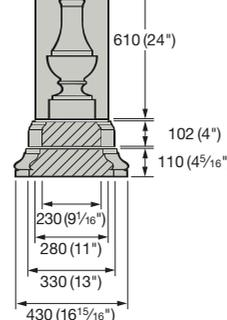

ARCHITECTURAL STONEWORK BALUSTRADING

The Spiral Balustrade

This is a very special type of balustrade and can be offered, as standard, only in the components and dimensions indicated in the table below.

TS Tech Sheet No. B60

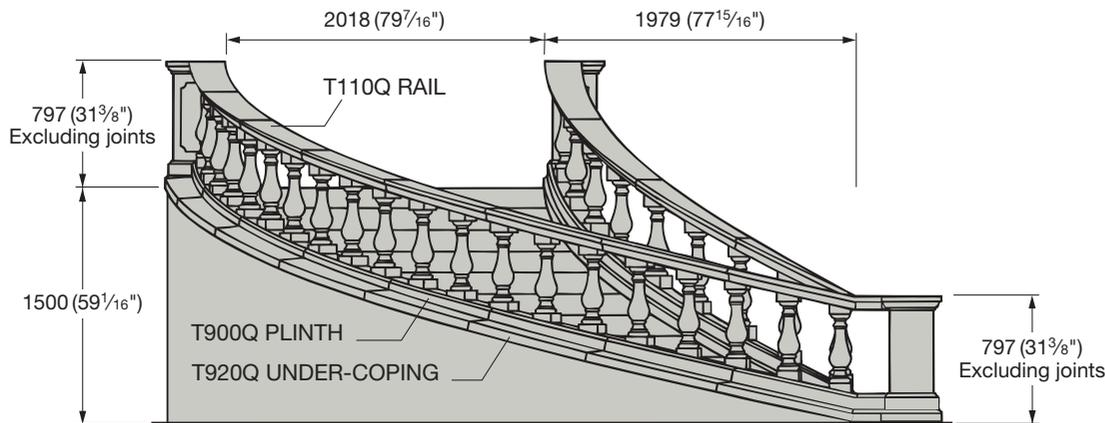

Left hand Spiral Balustrade illustrated above.

Dimensions	
Left and Right-handed 90° sweeps:	
Total Rise:	1500mm (59 ¹ / ₁₆ "")
Outer c/l Radius:	4112mm (161 ⁷ / ₈ "")
Inner c/l Radius:	1865mm (73 ⁷ / ₁₆ "")
Width of Staircase:	2018mm (79 ⁷ / ₁₆ "")
Components	
FS-style balustrading comprising:	
	T110-style Rail
	T900-style Plinth
	KG533-style Baluster
	T920-style Under-Coping (optional)



ARCHITECTURAL STONEMWORK BALUSTRADING

Installation Details

We recommend that non-ferrous fixings (available as part of the Balustrading Fixing Pack X950 - UK only) be incorporated at all rail joints and in horizontal beddings in all cases. All balusters are supplied with stainless steel dowels for installing to rails and plinths. All rails, plinths and under-copings are supplied in standard lengths, cutting and drilling to final specification to be undertaken by your installation contractor.

Professional advice should be taken particularly where Building Regulations / Codes and local bye-laws need to be complied with. It is recommended that, if pier shafts are in-filled with concrete, the shaft section should be lined with polystyrene (Styrofoam) or similar to act as an isolating medium.

Haddoncraft Forge has a range of wrought iron Baluster Bars for use in conjunction with Haddonstone balustrading, see image below. The bars can be used to meet Building Regulation spacing requirements.

PS style with K610G Balusters and T920 Under-Copings



FS style with K724G Balusters

Haddoncraft Forge Baluster Bar

THE STANDARD RANGE

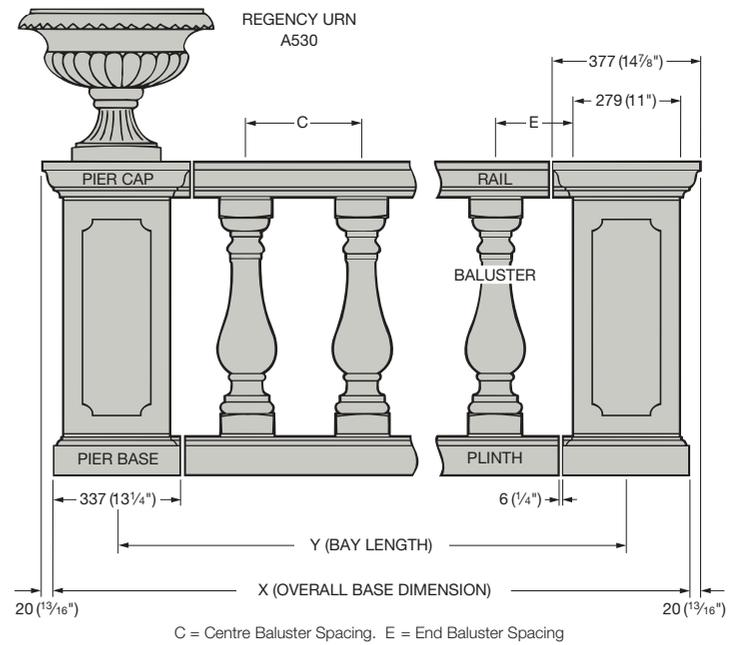

It is most important to refer to Tech Sheet GAR1 to ensure correct installation. Standard assembly recommendations and typical details are available on request. Please ask for the relevant Tech Sheet.

Cutting Recommendations:

General Assembly:

TS Tech Sheet No. B50

TS Tech Sheet No. GAR1

TABLE A

For normal baluster spacing: approx. 305mm (12") centres
Select highest band available unless there are other overriding factors

Band	Bay Lengths		Rails/Plinths	Balusters
	(centreline to centreline of piers) in mm	(centreline to centreline of piers) in inches	No. of 900mm (35 ⁷ / ₁₆ ") long rails/plinths and under-copings where applicable)	
1	-829	-32 ⁵ / ₈ "	1	1
2	830-1129	32 ¹¹ / ₁₆ "-44 ⁷ / ₁₆ "	1	2
3	1130-1249	44 ¹ / ₂ "-49 ³ / ₁₆ "	1	3
4	1250-1429	49 ¹ / ₄ "-56 ¹ / ₄ "	2	3
5	1430-1729	56 ⁵ / ₁₆ "-68 ¹ / ₁₆ "	2	4
6	1730-2029	68 ¹ / ₈ "-79 ⁷ / ₈ "	2	5
7	2030-2155	79 ¹⁵ / ₁₆ "-84 ¹³ / ₁₆ "	2	6
8	2156-2329	84 ⁷ / ₈ "-91 ¹¹ / ₁₆ "	3	6
9	2330-2629	91 ³ / ₄ "-103 ¹ / ₂ "	3	7
10	2630-2929	103 ⁹ / ₁₆ "-115 ⁵ / ₁₆ "	3	8
11	2930-3061	115 ³ / ₈ "-120 ¹ / ₂ "	3	9
12	3062-3229	120 ⁹ / ₁₆ "-127 ¹ / ₈ "	4	9
13	3230-3529	127 ³ / ₁₆ "-138 ¹⁵ / ₁₆ "	4	10
14	3530-3829	139"-150 ³ / ₄ "	4	11
15	3830-3967	150 ¹³ / ₁₆ "-156 ¹ / ₈ "	4	12

This table has been compiled to give an approximate Centre Baluster Spacing (see diagram) of 305mm (12") and a fixed End Baluster Spacing of 200mm (8").

The Standard Range

Tables A, B, C, D and E have been compiled to simplify the ordering of the STANDARD RANGE of balustrade components and enable you to design and price your own balustrade. Alternatively, approximate guide prices can be obtained from the price list.

You will also find below tables of the many horizontal curves and ramps available in the STANDARD RANGE – these are shown in Tables C and D.

The terms Weathered and Part-Weathered refer to the style of the balustrading rails and caps and not to the maturity of the stonework. For standard colours and finishes see page 194.

Haddonstone (USA) Ltd offers additional Balustrading and Parapet Screening designs to comply with specific Building Codes. For further details, refer to the Architectural Supplement or view:

www.haddonstone.com/view-catalogue

HOW TO USE TABLES A and B

By following this simple procedure you will be able to design, price and order your own balustrading from the STANDARD RANGE:

1. Choose type of baluster (see page 132) and style of balustrade (see pages 125, 126 and 127).
2. Measure the overall base dimension of each run of balustrading giving consideration to the fact that, particularly where balustrading abuts a wall, the cap oversails the base by 20mm ($13/16$ "), see diagram opposite.

TABLE B				
For close baluster spacing: approx. 225mm (9") centres Select highest band available unless there are other overriding factors				
Band	Bay Lengths		Rails/Plinths	Balusters
	(centreline to centreline of piers) in mm	(centreline to centreline of piers) in inches	No. of 900mm (35 7/16") long rails/plinths (and under-copings where applicable)	
16	-691	-27 ³ / ₁₆ "	1	1
17	692-916	27 ¹ / ₄ "-36 ¹ / ₁₆ "	1	2
18	917-1141	36 ¹ / ₈ "-44 ¹⁵ / ₁₆ "	1	3
19	1142-1249	45"-49 ³ / ₁₆ "	1	4
20	1250-1366	49 ¹ / ₄ "-53 ³ / ₄ "	2	4
21	1367-1591	53 ¹³ / ₁₆ "-62 ⁵ / ₈ "	2	5
22	1592-1816	62 ¹¹ / ₁₆ "-71 ¹ / ₂ "	2	6
23	1817-2041	71 ⁹ / ₁₆ "-80 ³ / ₈ "	2	7
24	2042-2155	80 ⁷ / ₁₆ "-84 ¹³ / ₁₆ "	2	8
25	2156-2266	84 ⁷ / ₈ "-89 ³ / ₁₆ "	3	8
26	2267-2491	89 ¹ / ₄ "-98 ¹ / ₁₆ "	3	9
27	2492-2716	98 ¹ / ₈ "-106 ¹⁵ / ₁₆ "	3	10
28	2717-2941	107"-115 ¹³ / ₁₆ "	3	11
29	2942-3061	115 ⁷ / ₈ "-120 ¹ / ₂ "	3	12
30	3062-3166	120 ⁹ / ₁₆ "-124 ⁵ / ₈ "	4	12
31	3167-3391	124 ¹¹ / ₁₆ "-133 ¹ / ₂ "	4	13
32	3392-3616	133 ⁹ / ₁₆ "-142 ³ / ₈ "	4	14
33	3617-3841	142 ⁷ / ₁₆ "-151 ¹ / ₄ "	4	15
34	3842-3967	151 ⁵ / ₁₆ "-156 ¹ / ₈ "	4	16

This table has been compiled to give an approximate Centre Baluster Spacing (see diagram) of 225mm (9") and a fixed End Baluster Spacing of 150mm (6").

3. Divide each run into suitable bays, generally incorporating piers at ends and corners.

4. When determining bay lengths, as a guideline, the highest band should be selected, but other overriding factors may need to be taken into account, such as achieving aesthetic balance, correlating with other architectural elements, relating bays to the height of the balustrade and the overall scale of the surroundings.

5. To calculate bay lengths, first deduct 337mm (13 1/4") from the overall base dimension to determine the distance between the centres of the end piers, then divide this figure by the number of bays required. Then refer to Tables A and B.

6. Should extra height be required or coping to a substructure, select appropriate under-coping to suit balustrading (see page 133).

7. Choose piers to suit balustrading layout, i.e. number of end piers, number of intermediate piers, number of corner piers.

8. ORDER CHECKLIST

The order should comprise total number of balusters, total number of rails, total number of plinths, total number of piers incorporating end piers, intermediate piers and corner piers as required.

TABLE C	TABLE D
Horizontal Curved Balustrade Rails and Plinths	Ramped Balusters
Available in both Flat and Weathered configurations in the following radii:	KG311 16° 18° 27°
500mm (19 1/16")	KG356 20° 27°
1000mm (39 3/8")	KG430 13°
1500mm (59 1/16")	KG457 13° 20° 27° 30° 33° 40°
2000mm (78 3/4")	KG464 16° 23°
2500mm (98 7/16")	KG520 23°
3000mm (118 3/8")	KG533 13° 16° 20° 21° 27° 30° 36°
3500mm (137 13/16")	KB609 27° 33° 42°
4000mm (157 1/2")	KG609 30°
4500mm (177 3/16")	KG610 13° 16° 20° 21° 23° 27° 30° 33° 36°
5000mm (196 7/8")	KJ610 27° 30° 36°
6000mm (236 1/4")	KG629 20° 27° 29° 31° 33°
7000mm (275 9/16")	KG724 13° 16° 20° 23° 26° 27° 29° 30° 33°
8000mm (314 15/16")	KG725 34° 1100 Balustrade
9000mm (354 5/16")	The ramp angle is the angle of rise/pitch measured from the horizontal.
10000mm (393 1/16")	
All radii to centrelines of plinth/rail.	

TABLE E					
Typical Component Weights					
Baluster Type:	K724G	K610G	K533G	K457G	K356G
	15kg (33 lb)	11kg (24 lb)	10kg (22 lb)	8kg (18 lb)	4.5kg (10 lb)
Standard pier to suit (complete):	105kg (231 lb)	97kg (214 lb)	87kg (191 lb)	81kg (178 lb)	75kg (165 lb)
135° pier to suit (complete):	154kg (339 lb)	147kg (323 lb)	134kg (295 lb)	121kg (266 lb)	120kg (264 lb)
T120A 900mm Standard Rail	31kg (68 lb)				
T900A 900mm Standard Plinth	30kg (66 lb)				

ARCHITECTURAL STONEMWORK BALUSTRADING

Standard Balusters These balusters are circular in section except top and bottom blocks which are square.

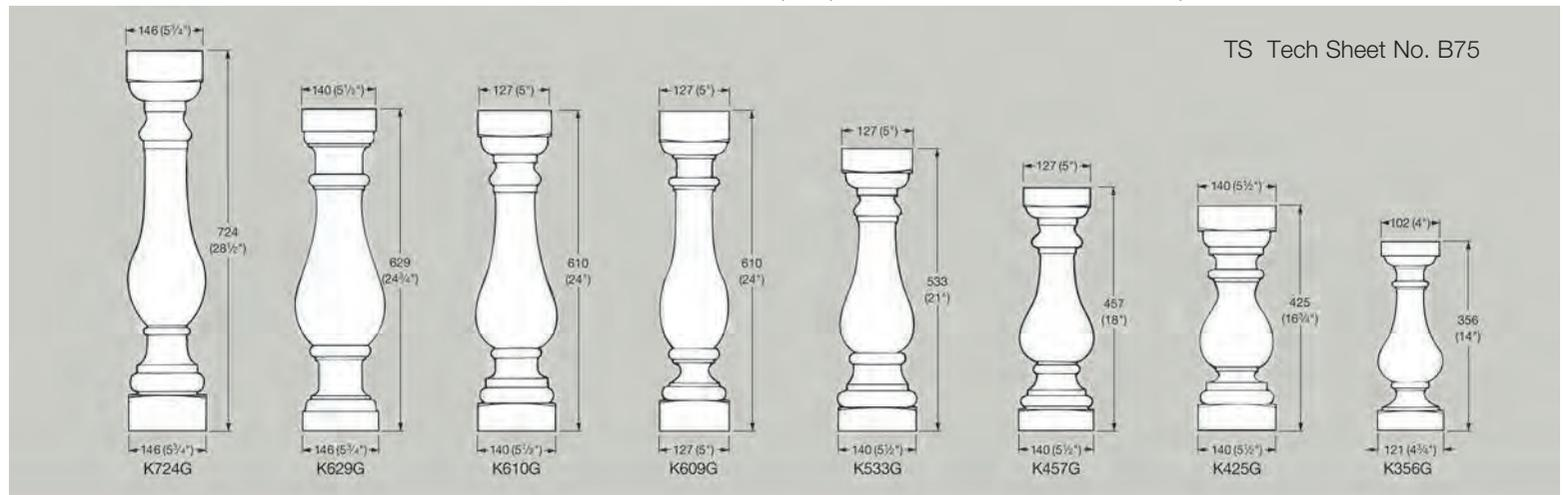

Non Standard Balusters Unless otherwise stated, these balusters are circular in section except top and bottom blocks which are square.

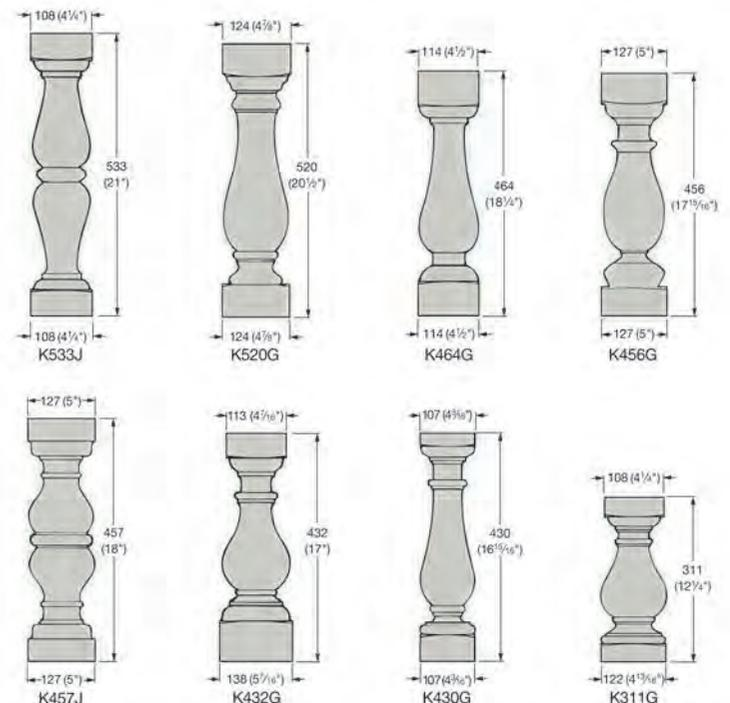
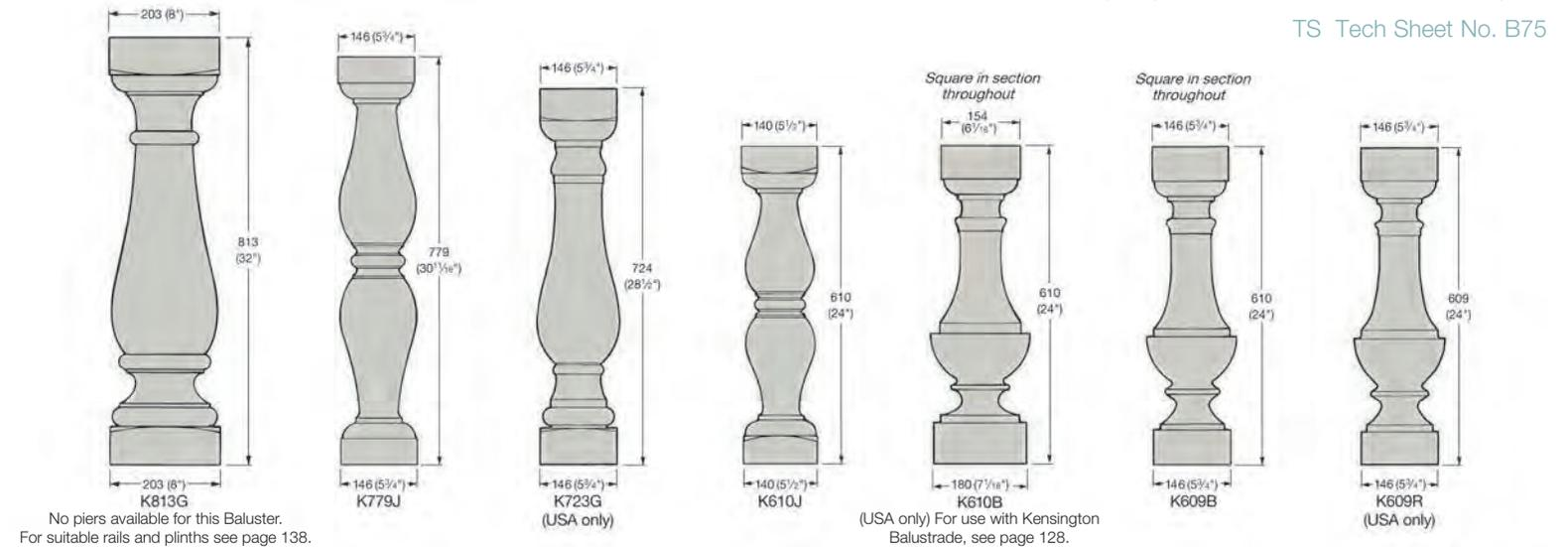

FS style with KG533 Ramped Balusters and T920 Wide Under-Copings

BALUSTRADE UNDER-COPINGS Optional, for use with the standard balustrading range. Available in 900mm (35⁷/₁₆") lengths only.

Pier Under-Coping 20kg (44 lb) 135° Pier Under-Coping 29kg (64 lb)

Narrow Central Run-In Under Copings

TS Tech Sheet No. B90

Deep central run-in under copings also available (USA only)

Plans show Pier Under-Copings

Narrow Side Run-In Under Copings

TS Tech Sheet No. B91

Deep side run-in under copings also available (USA only)

Plans show Pier Under-Copings

Wide Central Run-In Under Copings

TS Tech Sheet No. B92

Plans show Pier Under-Copings

Wide Side Run-In Under Copings

TS Tech Sheet No. B93

Plans show Pier Under-Copings

ARCHITECTURAL STONEMWORK PARAPET SCREENING

For a less formal and more decorative alternative to balustrading, parapet screening provides an effective solution.

As shown in the drawings, the length of parapet unit can be varied by using different combinations of the two basic panels J248 and J362. We show six of the most commonly used bays (TYPES A-F). The bay dimensions shown are from centreline to centreline of pier.

The piers are specially designed and produced for end, centre and corner use as well as for 135° angles; so when ordering please state clearly the number and reference of each type required.

All rails and plinths are supplied in standard lengths as indicated, cutting to final specification to be undertaken by your installation contractor.

TS Tech Sheet No. PS10



Parapet Screening (showing TYPE F bay)

Typical Component Weights

- J400A Rail: 16kg (35 lb)
- J400F Plinth: 25kg (55 lb)
- J248 End Panel: 9kg (20 lb)
- J362 Centre Panel: 13kg (29 lb)
- Standard Pier (complete): 76kg (167 lb)
- 135° Pier (complete): 151kg (332 lb)

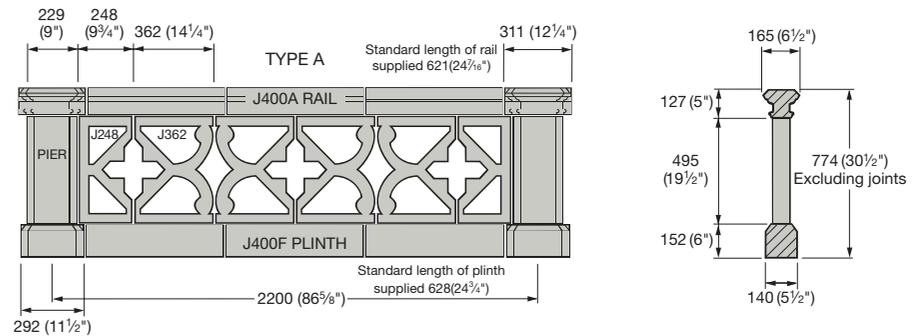

Plans showing Pier Caps

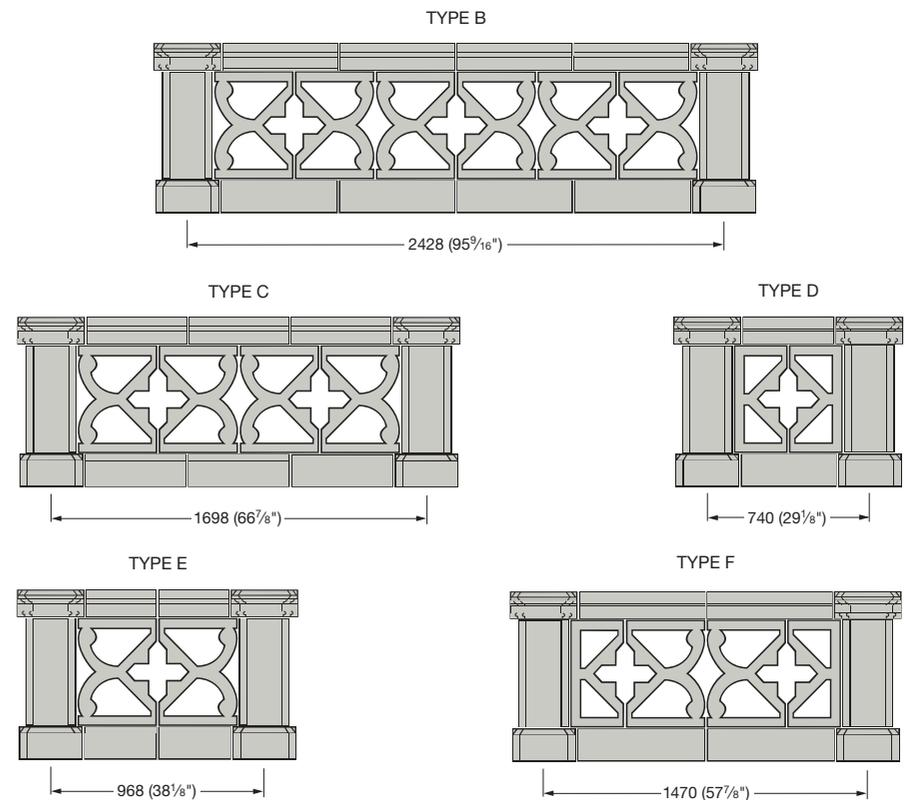
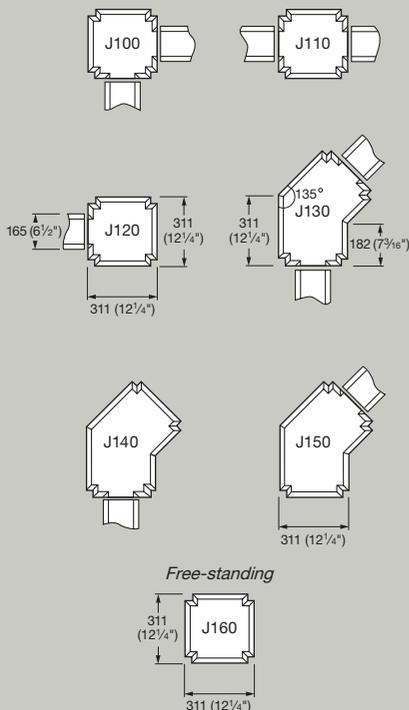

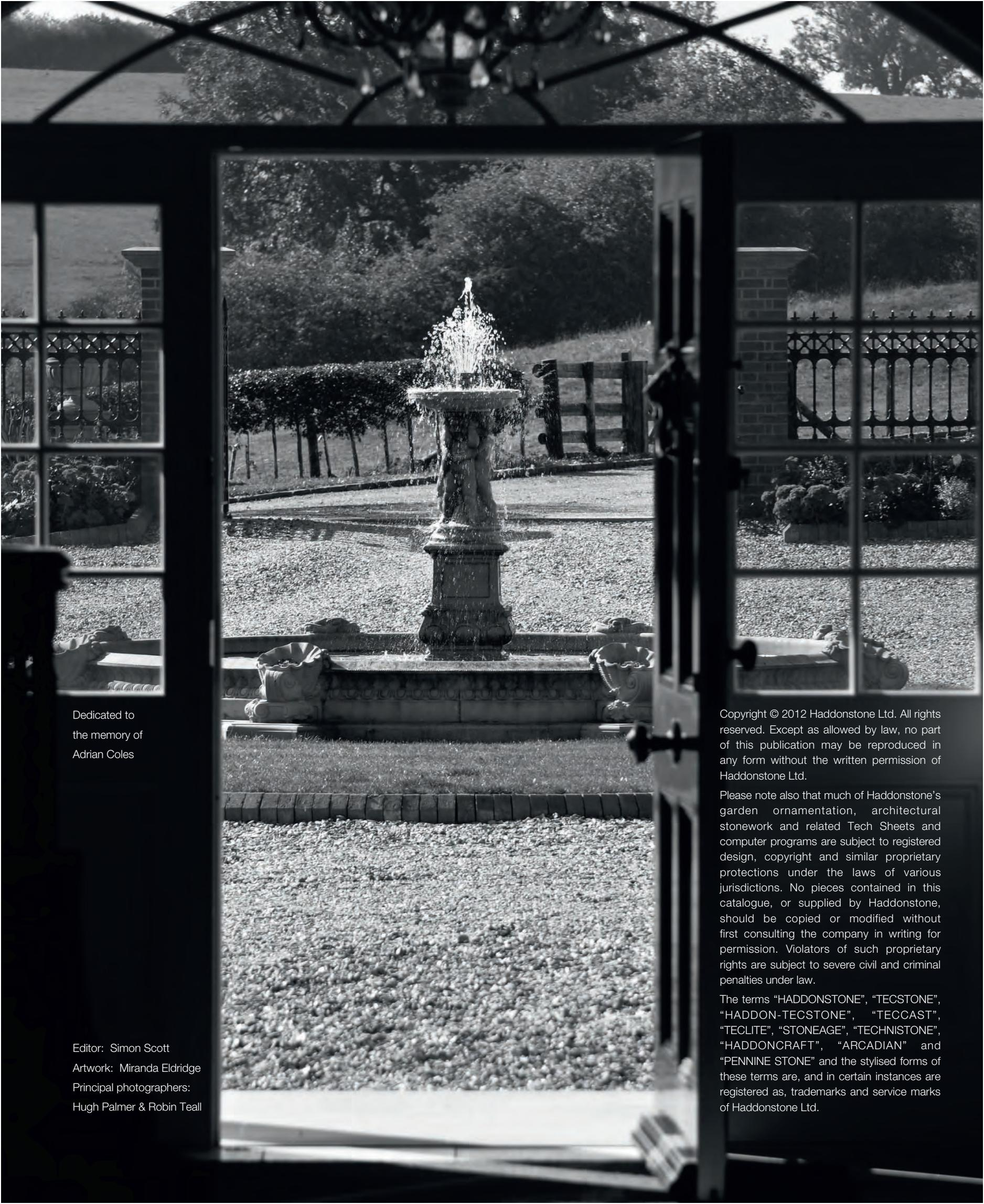

Dedicated to
the memory of
Adrian Coles

Editor: Simon Scott
Artwork: Miranda Eldridge
Principal photographers:
Hugh Palmer & Robin Teall

Copyright © 2012 Haddonstone Ltd. All rights reserved. Except as allowed by law, no part of this publication may be reproduced in any form without the written permission of Haddonstone Ltd.

Please note also that much of Haddonstone's garden ornamentation, architectural stonework and related Tech Sheets and computer programs are subject to registered design, copyright and similar proprietary protections under the laws of various jurisdictions. No pieces contained in this catalogue, or supplied by Haddonstone, should be copied or modified without first consulting the company in writing for permission. Violators of such proprietary rights are subject to severe civil and criminal penalties under law.

The terms "HADDONSTONE", "TECSTONE", "HADDON-TECSTONE", "TECCAST", "TECLITE", "STONEAGE", "TECHNISTONE", "HADDONCRAFT", "ARCADIAN" and "PENNINE STONE" and the stylised forms of these terms are, and in certain instances are registered as, trademarks and service marks of Haddonstone Ltd.



HADDONSTONE

Haddonstone Ltd,
The Forge House, East Haddon, Northampton NN6 8DB, England.
Telephone: 01604 770711 Fax: 01604 770027 info@haddonstone.co.uk

Haddonstone (USA) Ltd,
201 Heller Place, Bellmawr, NJ 08031, USA.
Telephone: 856 931 7011 Fax: 856 931 0040 info@haddonstone.com

Haddonstone (USA) Ltd,
32207 United Avenue, Pueblo, CO 81001, USA.
Telephone: 719 948 4554 Fax: 719 948 4285 stone@haddonstone.com

www.haddonstone.com

