

Function and Play value

This equipment is a nicely shaped water scoop where children can play and observe the flowing characteristics of water. When the wheel is turned around, water is drawn from the basin. The water then pours into the channels on both sides. It is directed by the channels into the flow dish and is redirected from there into the basin through a water outlet pipe. The water quantity coming into the channels varies with relation to the rotating speed of the wheel. The water can, for example, flow from both sides into the dish so that a constantly changing flow configuration results.



Fundamental characteristics

- special technical solution for water intake and distribution
- awarded design
- through water flow from both sides, special flow configurations can be observed
- the Scooping Wheel can also be combined with other water play systems
- unique and original
- incentive for playing: big wheel

**Scooping Wheel
Water Scoop**

Suitable

- for children from 5 years
- for water play areas of:
playgrounds
leisure areas
big water play installations

Copyright © Richter Spielgeräte GmbH 09/13

Design M. Rohrbach

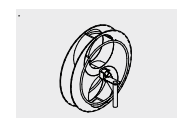

5.20880

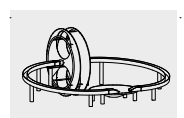

5.42010

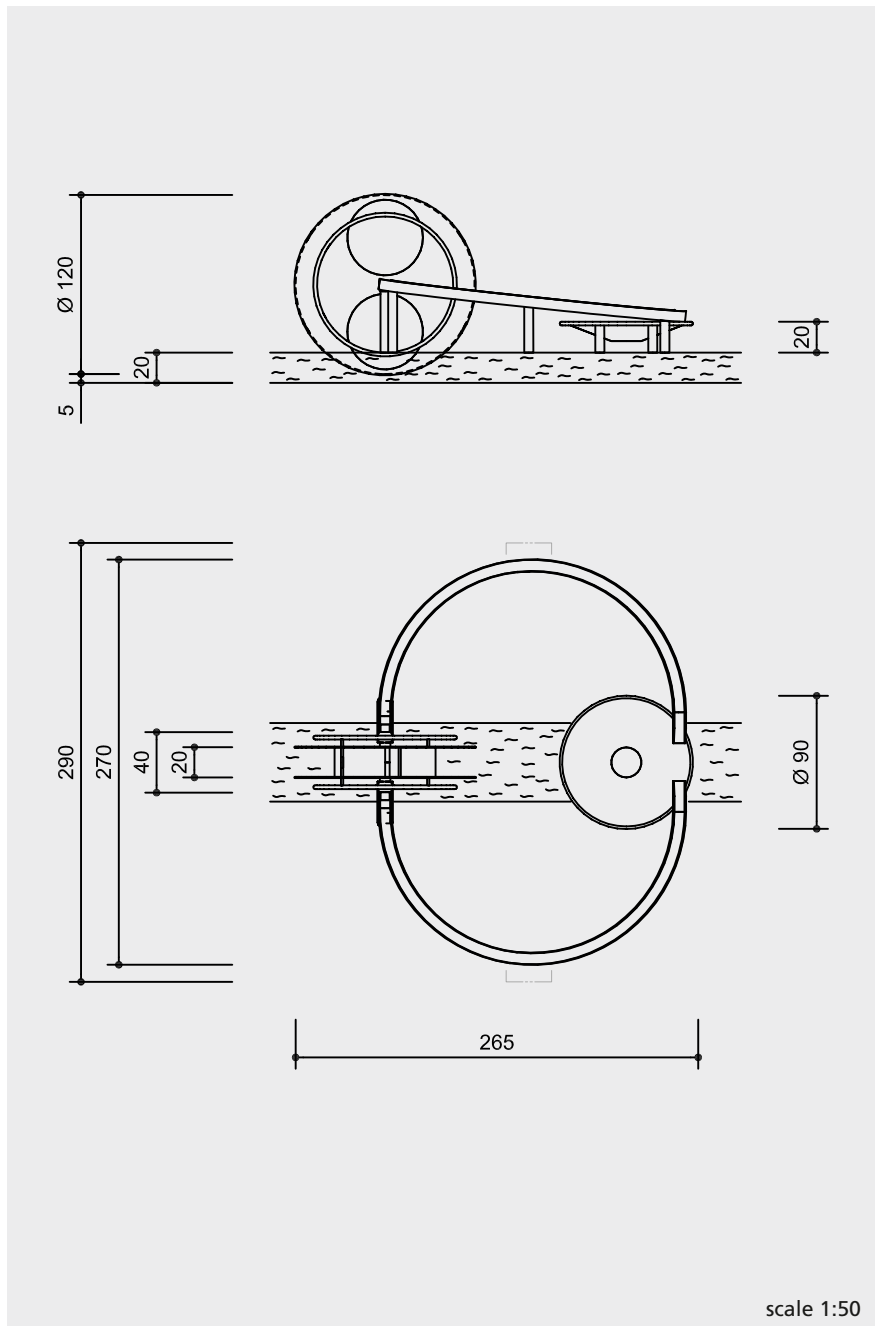

scale 1:50

Technical information

Total equipment of stainless steel

easy drive in maintenance free plastic bearings

grip-friendly rim

Dimensions

(small deviations possible)

equipment height	1.20 m
width	2.70 m
length	2.65 m
Scooping Wheel	
diameter	1.20 m
Flow Dish	
diameter	0.90 m
height	0.20 m
weight approx.	130 kg
Scooping Wheel approx.	70 kg

Safety check according to EN 1176

Components

Order No. 5.42010 Water Scoop

- 1 Scooping Wheel with bearings and alternating water runoff
- 2 water channels
- 1 flow dish

Order No. 5.20880 Scooping Wheel

- 1 Scooping Wheel with bearings and alternating water runoff
- 1 rack

Installation information

Surfacing requirements
no fall height according to standard
Recommendation: pavement or a similar surface with a runoff for water

- Water depth: for a proper function a min. water depth of 20 cm is required.
- Water supply and water basin have to be provided for on site.

Foundations

Order No. 5.20880 Scooping Wheel

- 2 items 50 x 30 x 40 cm

Channels

- 6 items 30 x 30 x 40 cm

Flow Dish

- 2 items 65 x 30 x 40 cm each 60 cm deep

Attention:

Exact measurements may vary, for all installation dimensions refer to current installation instructions.

Technical changes reserved.

For use in chlorine water the equipment is also available with a special steel alloy.



5.20880

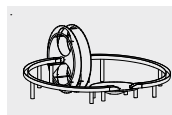

5.42010