

Instructions for wear checks of play equipment

Playground:

Date of installation:

Checks depend on the kind of equipment. Any equipment with moving parts must be checked at least twice a year, static equipment at least once a year.

Intervals for maintenance work and checks generally depend on:

- location
- kind of use
- frequency of use
- possible vandalism

For more details see also "General instructions for maintenance of playgrounds"

Water Scoop
Order no. 5.42010

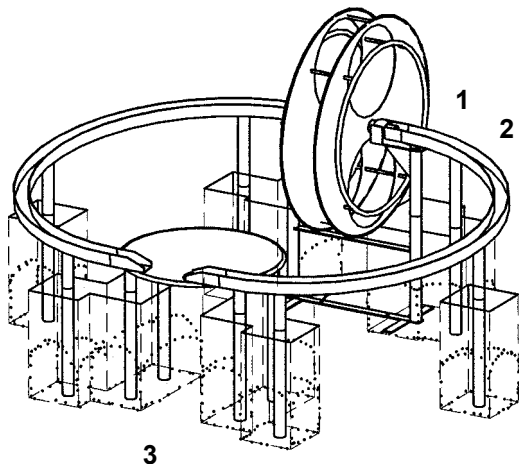

The equipment must be checked for correct operation and safety, especially the points listed below:

Water Scoop

1 Check the bearings for smooth motion and for wear, if necessary renew

2 Check all connections for firmness

Structural stability

3 Check the foundations once a year for underwashing or collapsing (may cause wobbling of the Water Scoop). Refill with ground material

Proof of maintenance

1. 2. 3.

etc.

Special notes (e. g. for repairs):
Special notes (e. g. for repairs):
Special notes (e. g. for repairs):

Repair not carried out, it is still possible to play on the equipment

Repair not carried out, equipment is taken out of action

All work carried out, everything is in order

Maintenance carried out by

Date