

Instructions for wear checks of play equipment

The equipment must be checked for correct operation and safety, especially the points listed below:

Proof of maintenance

Playground

Date of installation

Checks depend on the type of equipment. Any equipment with moving parts must be checked at least twice a year, static equipment at least once a year.

Intervals for maintenance work and checks generally depend on

- location
- kind of use
- frequency of use
- possible vandalism

For more details see also "General instructions for maintenance of playgrounds".

Balance Blocks
Order No. 6.51700/6.51701

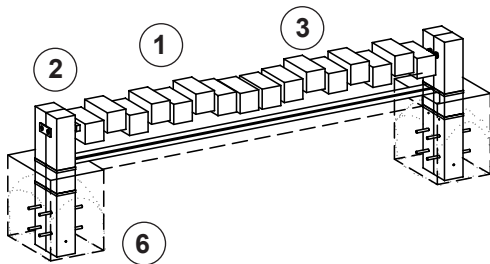

detailed diagram A

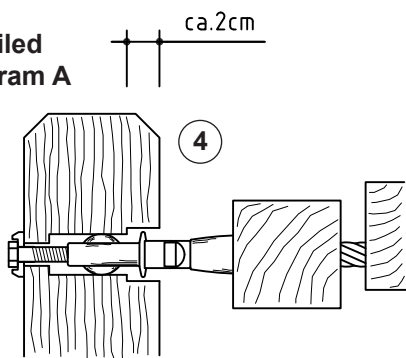

detailed diagram B

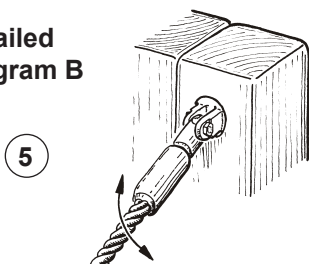

Wooden parts

1. Check for rot and, if necessary, smooth splinters and round off sharp edges of cracks.
2. **Recommendation:** apply paraffin wax to the upper end grain areas once a year, please refer to order No. 0.90100.

Carrying ropes

3. Check for wear and tear.
4. Check wood connections, re-tension if necessary, they can be retightened by approx. 2 cm (see detailed diagram A).
5. Check joint of the carrying rope for wear and tear and make sure connections move smoothly (see detailed diagram B).

Structural stability

6. In order to check for rot at wooden parts or the steel feet for corrosion, uncover the foundation once a year.

Repair not carried out, it is still possible to play on equipment

Repair not carried out, equipment is taken out of action

All work carried out, everything is in order

Maintenance carried out by:

..... Date

For spare parts refer to back of page.

Special notes, e.g. for repairs

Spare Parts
Balance Blocks
Order No. 6.51700/6.51701

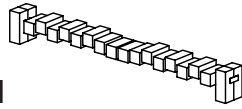

Please note that the safety standards of the equipment must not be affected. Therefore, when carrying out repairs it is helpful to **only use original parts.**

Order No. Spare part

0.85200 carrying rope

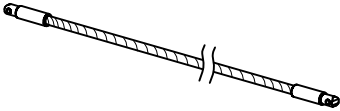

99.00370 block for balance blocks, 2 parts, pre-drilled

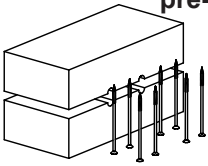

99.01276 distance beam



99.01090 support frame with joints



99.01277 support frame without joints, pre-drilled



0.90100 paraffin wax, 1 litre