

Play value

The caterpillar is a friendly play offer for small children. The harmonious appearance of the figure and the way in which it is possible to play from both sides offer a lively and pleasant basis for smaller playing spaces. The space partitions promote communicative play, but also make it possible to create borders and divisions of the play areas. This caterpillar type is equipped with coloured discs, a marble run and rotating discs.



Fundamental characteristics

- friendly appearance
- coloured discs
- rotating discs

Suitable

- for small children's areas of:
 - public playgrounds
 - playgrounds situated near houses
 - kindergartens
 - children's homes
 - therapy institutions for children
 - camping sites
- nurseries

Planning information

The angles of the opposing wall elements and their number can be freely selected to a great extent. Both spread-out as well as more compact floor plans can be constructed. By freely selecting and arranging the individual elements, it is possible to carry out planning according to your requirements. The elements can also be used as partitioning play units without caterpillar head and tail.

Note

In the standard version, only the head and tail use colour in their design. The elements installed in between are also available with coloured trims at extra charge.

Caterpillar type 02

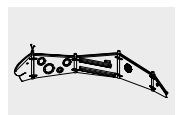

5.00015

Example of installation

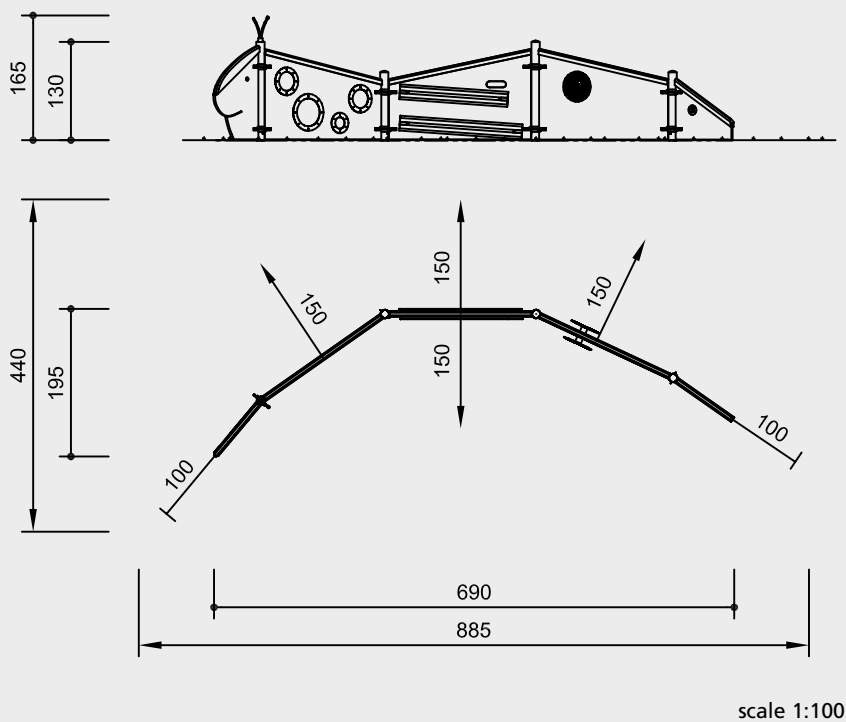

Safety check according to EN 1176

Components

- 1 head with horns
- 1 element: coloured discs
- 1 element: marble run with 6 balls
- 1 element: rotating discs
- 1 tail with bell

Installation information

Surfacing requirements corresponding to a fall height of ≤ 0.60 m (please refer to price list for more detailed information)

Foundations
 4 items 50 x 50 x 40 cm excavation depth 60 cm
 2 items 30 x 30 x 30 cm excavation depth 50 cm

Attention:
 Exact measurements may vary, for all installation dimensions refer to current installation instructions.

Technical changes reserved.

Technical information

equipment of non-impregnated mountain larch

core-free
 sawn timbers core-free, thus decreasing the occurrences of cracking



plywood
 wall elements made of waterproof mountain larch plywood board, 30 mm



Corocord® rope special ropes of "Hercules type"
 horns of six-strand Corocord® rope of the special "Hercules type", abrasion-protected through heating of the six steel strands and melting the polyester or polyamide sleeve onto them, standard colour rainbow



ground anchor
 posts for bolt on, head and tail with foundation irons made of hot-dip galvanised steel



posts made of stainless steel, glass bead blasted

bell made of brass

colour
 colouring with solvent-free acrylic paints; the wood is processed in a way that allows the structure of the wood to remain clearly visible

Rotating Discs
 disc made of PVC hard integral foam printed-on black and white motif anti-glare surface

ball bearing
 low-maintenance ball bearings maintenance-free ball bearings (long-lasting turning action)



flange and fastening bolts made of stainless steel

Coloured Discs
 made of acrylic glass 3 mm, fastening frame made of stainless steel

Dimensions
 (small deviations possible)

height	1.65 m
height of head	1.30 m
length of the element	
head	1.00 m
middle part	2.00 m
tail	1.00 m
weight	260 kg

For more detailed explanation of the quality characteristics see price list.

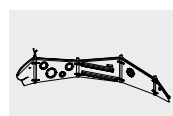

5.00015