

Digital electropneumatic positioner for the integrated mounting on process control valves



- Compact, robust stainless steel design
- Start-up by automatic Tune function
- Contact-free position sensor
- Integrated control air routing
- Fieldbus interface AS-Interface (option)

Type 8694 can be combined with...



Type 2301

Globe control valve



Type 2300

Angle-seat control valve



Type 2103

Diaphragm control valve

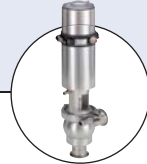

Hygienic process control valves

Compact positioner for integrated mounting on pneumatically operated process valves. Remote setpoint adjustment via a 4-20 mA signal or through AS-Interface. A contact-free analog position sensor measures the position of the valve spindle. Simple installation through automatic tune function and setting through DIP-switch:

- Close tight function
- Characteristic curves selection
- Reversal of effective direction
- Switching manual /automatic operation
- Binary input

Additional parametrisation options are possible through DTM devices. A software interface can be used for, amongst others, linearisation of the operation characteristics by using free programmable fixed points. The valve position indication is shown through LED components. As an option an analogue position feedback can be integrated.

Technical Data	
Material	Body Cover Sealing
	PPS, stainless steel PC EPDM
Power supply	24 V DC ±10% UL: NEC Class 2
Residual ripple	max. 10%
Setpoint setting	4 to 20 mA (0 to 20 mA adjustable via communication interface)
Output resistance	180 Ω
Control medium	neutral gases, air, quality classes acc. to ISO 8573-1
	Dust concentration Class 7 (<40 µm particle size)
	Particle density Class 5 (<10 mg/m ³)
	Pressure condensation point Class 3 (<-20 °C)
	Oil concentration Class X (<25 mg/m ³)
Ambient temperature	-10 °C to +55 °C
Pilot air ports	Threaded ports G 1/8 stainless steel or push-in connector (tube Ø 6 mm / 1/4")
Supply pressure	Low air flow rate 0 to 7 bar ¹⁾ High air flow rate 3 to 7 bar
Air input filter	Exchangeable (mesh aperture~0.1 mm)
Actuator system	Actuator series ELEMENT 23xx
	Low air flow rate : Ø Actuator 70 / 90 mm High air flow rate: Ø Actuator 130 mm
Position detection module	Contact-free, wear-free
Stroke range valve spindle	3 to 45 mm
Installation	as required, preferably with actuator in upright position
Protection type	IP65/IP67 acc. to EN 60529, Type 4X acc. to NEMA 250 standard
Protection class	3 acc. to DIN EN 61140
Approvals	ATEX II cat. 3G/D cULus Cert. No. 238179
Ignition protection	II 3D Ex tc IIIC T135 °C Dc II 3G Ex nA IIC T4 Gc
Conformity	EMC directive 2014/30/EU
Options	Analogue position feedback, 4-20 mA
Communication	AS-Interface (option, in preparation)

¹⁾ The supply pressure has to be 0,5 - 1 bar above the minimum required pilot pressure for the valve actuator.

Technical data - cont.

Without filed bus communication	
Power supply	24 V DC +/- 10% UL: NEC Class 2
Risidual ripple	10%
Power consumption	< 3.5 W
Electrical connection	
Multipole	M12 (8 pins), stainless steel
Cable gland	1xM16x1.5 (cable Ø 5-10), terminal screws (1.5 mm ²)

Technical data AS-interface - (Option)	
Profile	S-7.3.4 Output: 16 Bit setpoint / Certificate no. 87301 acc. to Version 3.0 -7.A S.5 Output: 16 Bit setpoint; Input: 16 Bit feedback / Certificate no. 95401 acc. to version 3.0
Programmed Information	see operating instructions
Power supply through bus line	29,5 to 31,6 V DC acc. to specification UL: NEC Class 2
Max. Current consumption	150 mA
Electrical connection	M12x1, 4-pin stainless steel plug assembled to 80 cm cable and flat cable clip

Ordering information for ELEMENT TopControl control valve systems

A TopControl control valve system consists of a **BASIC positioner Type 8694** and an **ELEMENT control valve Type 23xx/2103**.

The following information is necessary for the selection of a complete system:

- **Item no.** of the BASIC TopControl positioner **Type 8694** (see ordering chart on p. 4)
- **Item no.** of the desired control valve **Type 23xx** (see separate datasheet 2300, 2301 2103)

You order two components and receive a complete assembled and certified valve.

Click on the orange box "More info." below... you will come to our website for the resp. product where you can download the datasheet..

Example of variations of control valve systems

BASIC positioner Type 8694

Pneumatic process control valves



Control valve system



**Control valve system
ELEMENT
Type 8802-GD-L
2301 + 8694**

**Control valve system
ELEMENT
Type 8802-YG-L
2300 + 8694**

**Control valve system
ELEMENT
Type 8802-DF-L
2103 + 8694**

**Customised attachment
to 3rd party actuators***

*: please see datasheet **8681/ELEMENT** installation kits to 3rd party process valves or contact your sales office for related drawings or individual engineering support]

Ordering chart Type 8694 (other versions on request)

Control function Pilot valve system	Communi- cation	Electrical connection	Analogue feedback	Pilot air ports threaded ports	Item no.	
Actuator series ELEMENT Type 23xx, size Ø 70/90 mm					Standard	ATEX II cat. 3G/D
Low air capacity single-acting		M12 multipole		G 1/8	227 405	265 046
			yes	G 1/8	227 406	265 047
		Cable gland		G 1/8	227 401	265 044
	yes		G 1/8	227 402	265 045	
	AS-Interface S-7.A.5	M12 connector /flat cable clip / 80 cm cable	16 Bit via Bus	G 1/8	239 615	265 043
Actuator series ELEMENT Type 23xx, size Ø 130 mm						
High air capacity single-acting		M12 multipole		G 1/8	227 426	265 059
			yes	G 1/8	227 427	265 060
		Cable gland		G 1/8	227 422	265 057
	yes		G 1/8	227 423	265 058	
	AS-Interface S-7.A.5	M12 connector /flat cable clip / 80 cm cable	16 Bit via Bus	G 1/8	239 616	265 056

Note: All non-ATEX versions are UL approved.

i Further versions on request

- > Additional**
Push-in pilot air ports (tube Ø 6 mm / 1/4")

Ordering chart adapter kit (has to be ordered separately)

Description	Actuator size	Control function	Item no.
Adapter kit ELEMENT Types 23xx/2103	Ø 70 / 90 / 130 mm	universal	679 917

for installation kits to 3rd party process valves please see datasheet 8681/ELEMENT or contact your sales office for related drawings or individual engineering support

Ordering chart accessories

Description	Item no.
M12 socket 8-pin with 5 m cable for power supply and input/output signals	919 267
Silencer G 1/8	780 779
Silencer, push-in connector	902 662
Sensor puck (spare part)	682 240
USB interface for serial communication	227 093

Materials

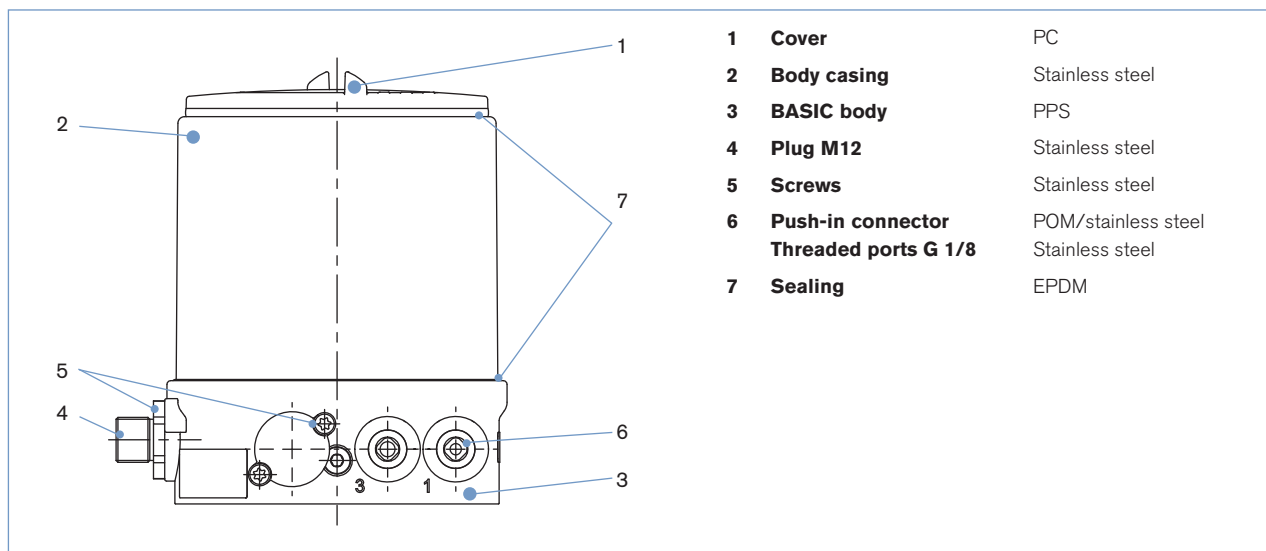

Dimensions [mm]

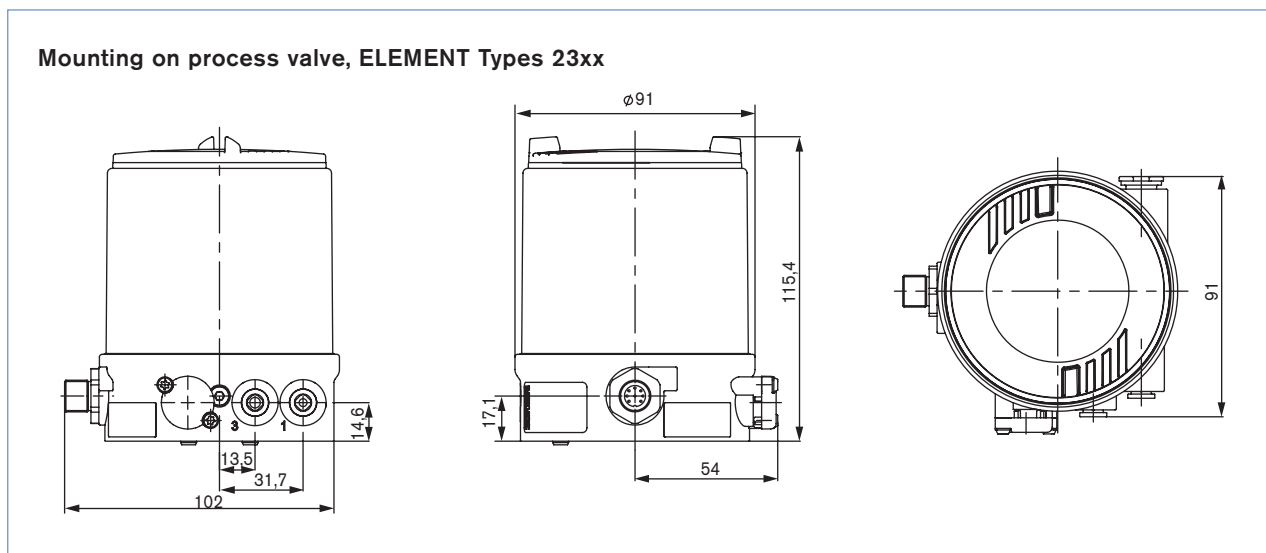

Mounting on third party hygienic process valves



**Customised attachment
to 3rd party actuators***

*: please see datasheet 8681/ELE-
MENT installation kits to third party
process valves or contact your sales
office for related drawings or individual
engineering support]

Connection options

Multipole connection

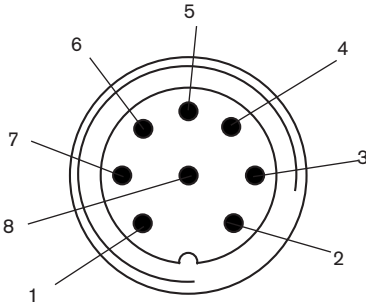

Pin	Configuration
1	Setpoint + (0/4-20 mA)
2	Setpoint GND
3	Operating voltage GND
4	Operating voltage + 24 V DC
5	Binary input +
6	Binary input GND
7	Analogue position feedback GND
8	Analogue position feedback +

Connection cable gland

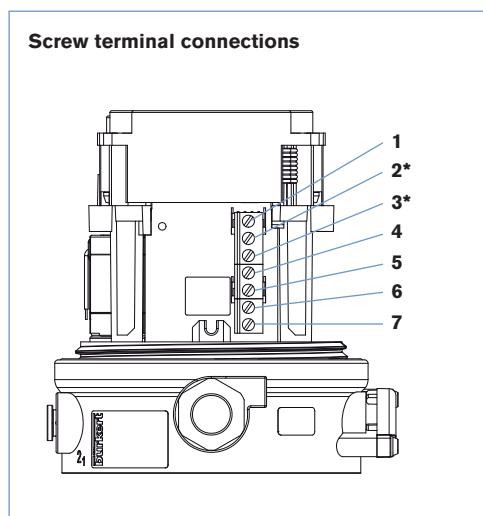

* Option only

Input signal

Pin	Configuration
4	Setpoint +
5	Setpoint GND
1	Binary input +
6	Power supply +
7	Power supply GND

Output signal with analogue feedback option

Pin	Configuration
2	Analogue feedback +
3	Analogue feedback GND

Connection options (cont.)

Connection AS-Interface

M12 4-pin plug assembled to 80 cm cable and flat cable clip

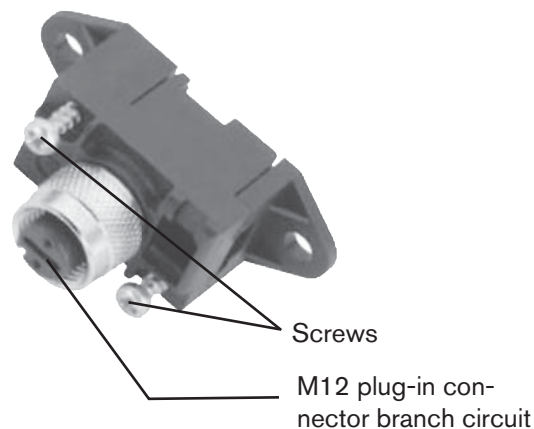

Plug layout: from front looking at the pins, the solder is behind

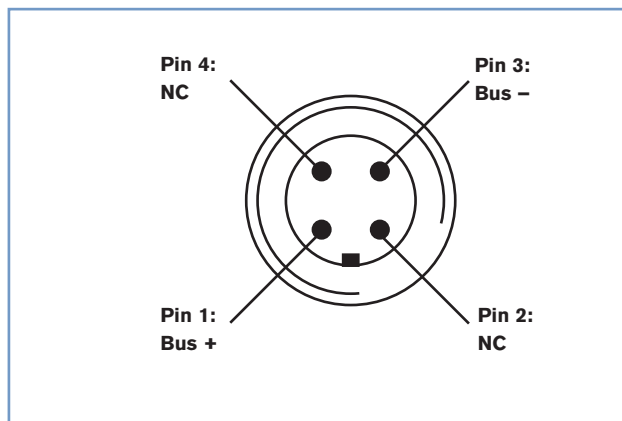

Bus connection without external power supply

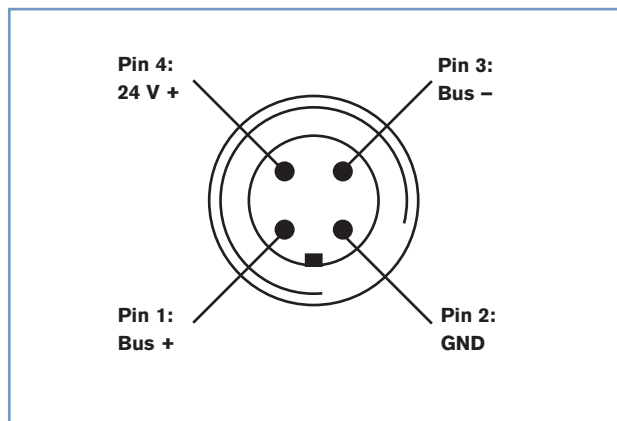

Bus connection with external power supply (on request)

Pin	Designation
1	Bus +
2	NC or GND (optional)
3	Bus -
4	NC or 24 V + (optional)

Signal flow diagram

Position control loop

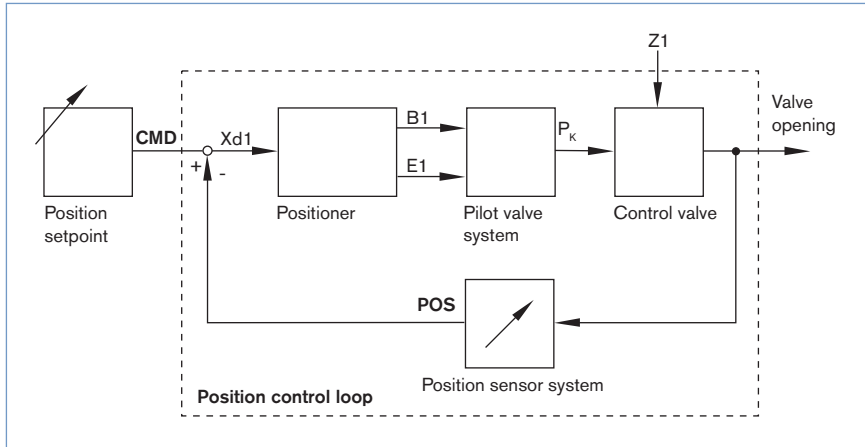

TopControl BASIC functions

- X.Tune function for automatic start-up
- Linear
- Close-tight function
- Reversal
- Switching
- Binary input
- Parametrisation of the device through PactWare/DTM main functions:
 - Setpoint value selection (0/4-20 mA)
 - Position controller parametrisation
 - Programmable stroke range limit
 - Limitation of opening/closing time
 - Safety position definition
 - Signal error detection
 - Binary input configuration
 - Analogue output configuration position setpoint/feedback
 - Setting setpoint/actuator direction (rise/fall)
 - Reset device

Schematic diagram of the TopControl BASIC

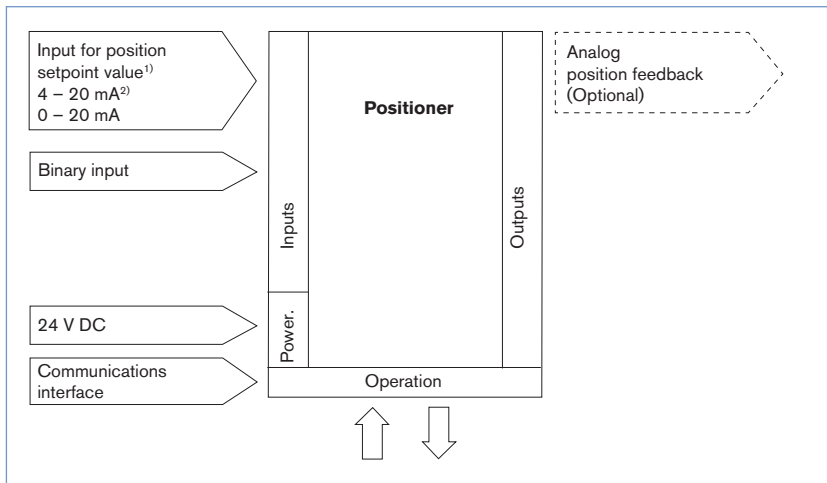

¹⁾ or optional bus connection AS interface
²⁾ Default setting

To find your nearest Bürkert facility, click on the orange box → www.burkert.com