



Pressure controller for precise time-pressure dosing

- Repeatable and accurate dosing of liquids in μl range
- Response time in milliseconds and active pressure relief for best control performance
- Digital communication for easy integration into your fieldbus network
- Extended functionality through additional sensor input + actuator output e.g. for pump or additional sensor
- Active vent valve to minimize consumption of costly carrier gas

Product variants described in the data sheet may differ from the product presentation and description.

Can be combined with

	Type 6712 2/2 way Whisper Valve with media separation	▶
	Type 6724 2/2 or 3/2 way Whisper Valve with media separation	▶
	Type ME43 Fieldbus gateway	▶
	Type 6650 2/2 or 3/2 way Flipper-Solenoid Valve with separating diaphragm	▶

Type description

Time-pressure dosing is a very common method for the reliable dosing of liquids in many fields of application. However, if the dosing quantities are very small and the pressure differences between dosing cycles are minimal, pressure control becomes a challenge. Type 8763, the pressure regulator specially developed for low flow rates and thus small dosing quantities, meets precisely this challenge. Short reaction times and the precise regulation of the pressure characterize this device. There are no down times or rejects at the beginning of dosing cycles. The digital interface makes it possible to access various parameters at any time, change settings and read out data. Whether it is a filling system or state-of-the-art machines for genetic analysis and synthesis, a good valve alone is not enough, precise pressure control is also essential for accuracy in time-pressure dosing.

Table of contents

1. General technical data	3
<hr/>	
2. Materials	4
2.1. Chemical Resistance Chart – Bürkert resistApp.....	4
2.2. Materials in the fluid channel	4
<hr/>	
3. Dimensions	5
3.1. Digital version	5
<hr/>	
4. Device/Process connections	6
4.1. Electrical connection	6
<hr/>	
5. Performance specifications	7
5.1. Dosing examples	7
General structure	7
Dosing example dosing time 50 ms	7
Dosing example dosing time 500 ms	8
Dosing example varying target pressure	8
5.2. Flow characteristic.....	9
Flow rate of versions with atmosphere at the outlet.....	9
Flow rate of versions with pressure ratio “target pressure to supply pressure”	9
<hr/>	
6. Ordering information	10
6.1. Bürkert eShop – Easy ordering and quick delivery.....	10
6.2. Bürkert product filter.....	10
6.3. Ordering chart.....	10
6.4. Ordering chart accessories.....	10

1. General technical data

Performance data	
Medium	Air Non-flammable, neutral gases (nitrogen, argon); oil-free
Gas control volume	30...250 ml (other volumes on request)
Supply pressure p_1	0.2...3 bar / 2,9...43,5 Psi (supply pressure > target pressure)
Control range/Control accuracy in steady state	0.006...0.35 bar / 0,087...5,07 Psi (± 1.225 mbar / 0,0177 Psi) ^{1.)} 0.02...1.0 bar / 0,29...14,5 Psi (± 3.5 mbar / 0,05 Psi) ^{1.)} 0.04...2.0 bar / 0,058...29 Psi (± 7 mbar / 0,01 Psi) ^{1.)}
Reproducibility + Control accuracy	< ± 0.35 % FS according to Bürkert standard measurement setup
Temperature compensation	Yes
Reaction time	< 25 ms (sensor captures + adjustment of the control valve) Target pressure change 0...1 bar (0...14,5 Psi): 600 ms typical (supply pressure 3 bar (43,5 Psi) at 30 ml)
Product connections	
Input	G $\frac{1}{8}$
Output controlled	UNF $\frac{1}{4}$ " -28
Output switched (pressure relief)	Ventilation hole
Electrical data	
Operating voltage	18...35 V DC
Power consumption (max.)	< 6 W (2.4 W typical with connected additional consumers < 12 W)
Connections	See "3. Dimensions" on page 5
Medium data	
Medium temperature	+ 15... + 40 °C
Approvals and certificates	
Protection class	IP20
Certified materials	On request
Environment and installation	
Ambient temperature	+ 15... + 40 °C (maximum) Extension on request
Filter	36 μ m input filter

1.) In steady state means constant flow of medium

2. Materials

2.1. Chemical Resistance Chart – Bürkert resistApp



Bürkert resistApp – Chemical Resistance Chart

You want to ensure the reliability and durability of the materials in your individual application case? Verify your combination of media and materials on our website or in our resistApp.

[Start Chemical Resistance Check](#)

2.2. Materials in the fluid channel

The materials at the pressure inlet and at the pressure outlet are described. In the case of venting, the materials of the pressure outlet are in direct contact with the media that may be degassing, i.e. PPS and FFKM.

The control is designed in such a way that when venting takes place through the thread hole, out-gassed media are not in contact with the materials of the pressure input side, these are FKM, PTFE, brass and stainless steel.

Note:

Other materials are available on request.

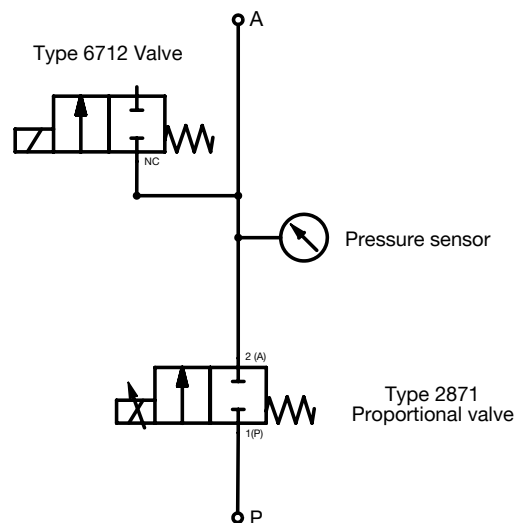
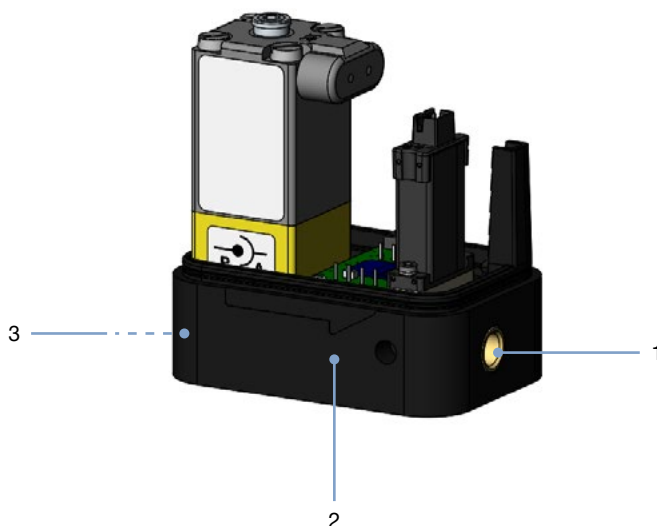

No.	Element	Material
1	Pressure outlet	PPS and FFKM
2	Pressure sensor	Silicon, FKM
3	Pressure input	FKM, PTFE, brass and stainless steel

3. Dimensions

3.1. Digital version

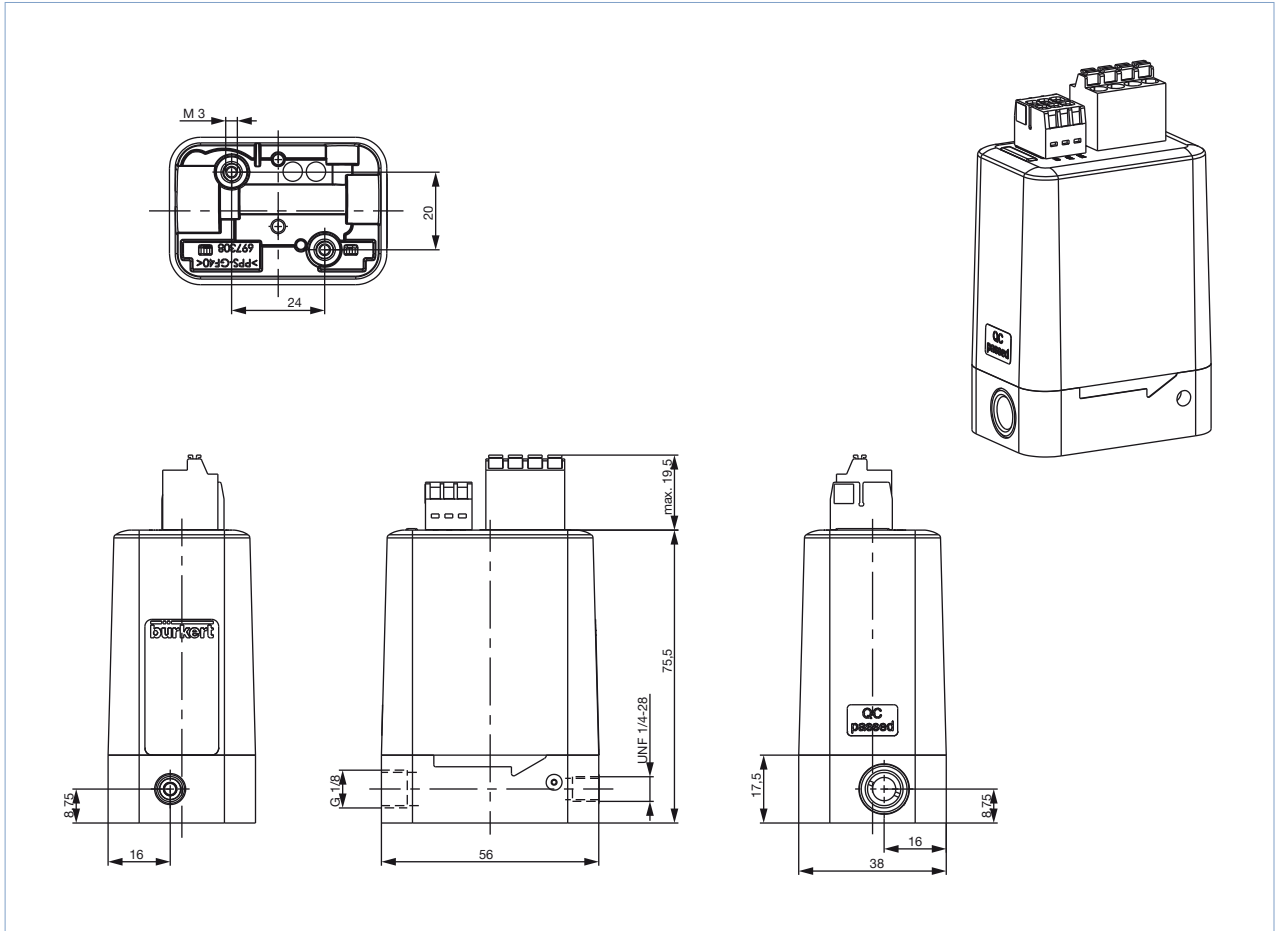

4. Device/Process connections

4.1. Electrical connection

Digital

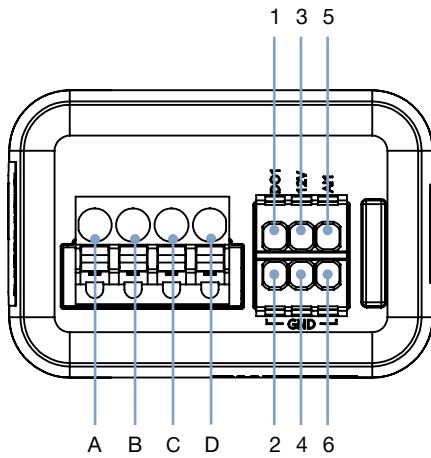

No.	Value
A	GND
B	CAN low
C	CAN high
D	18...35 V DC
1	DO1 12 V DC switchable e.g. pump
2	GND
3	Output voltage 12 V DC sensor supply
4	GND
5	AI1 (external sensor input)
6	GND

5. Performance specifications

5.1. Dosing examples

General structure

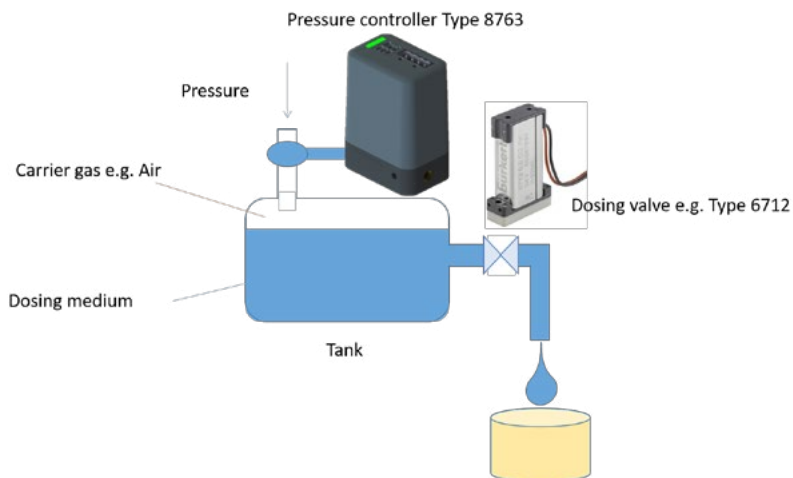

Dosing example dosing time 50 ms

Type 8763 (Article no.: 328290)	
Parameter	Value
Supply pressure	2 bar (29 Psi)
Container air volume	50 ml
Dosing valve	Article no.: 273203
Dosing time/valve switching time	50 ms
Dosing medium	Water
Hose length tank	500 mm
Hose cross-section tank	2.36 mm
Hose length tank dosing valve	350 + 200 mm
Hose cross-section tank dosing valve	1.58 mm
Target pressure	138 mbar (2 Psi)
Dead band	0.05 %

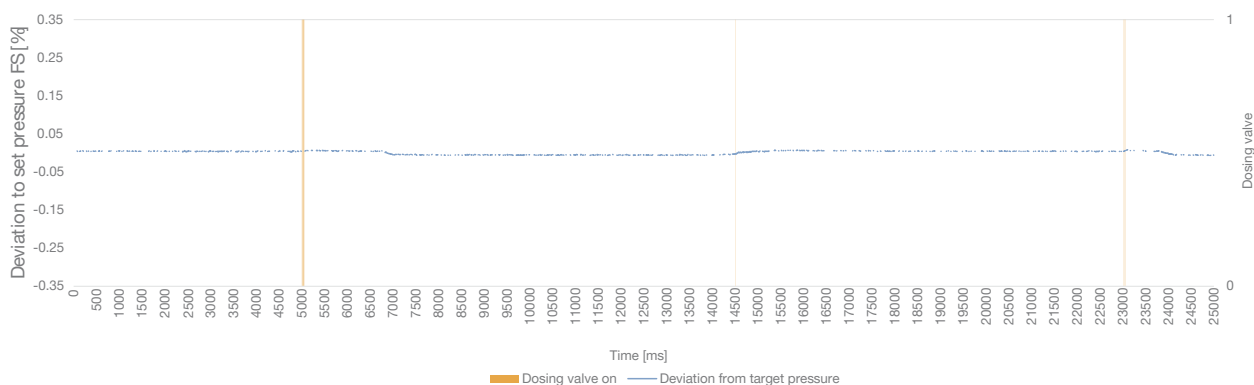

Dosing example dosing time 500 ms

Type 8763 (Article no.: 328290)	
Parameter	Value
Supply pressure	2 bar (29 Psi)
Container air volume	50 ml
Dosing valve	Article no.: 273203
Dosing time/valve switching time	500 ms
Dosing medium	Water
Hose length tank	500 mm
Hose cross-section tank	2.36 mm
Hose length tank dosing valve	350 + 200 mm
Hose cross-section tank dosing valve	1.58 mm
Target pressure	500 mbar (7,25 Psi)
Dead band	0.05 %

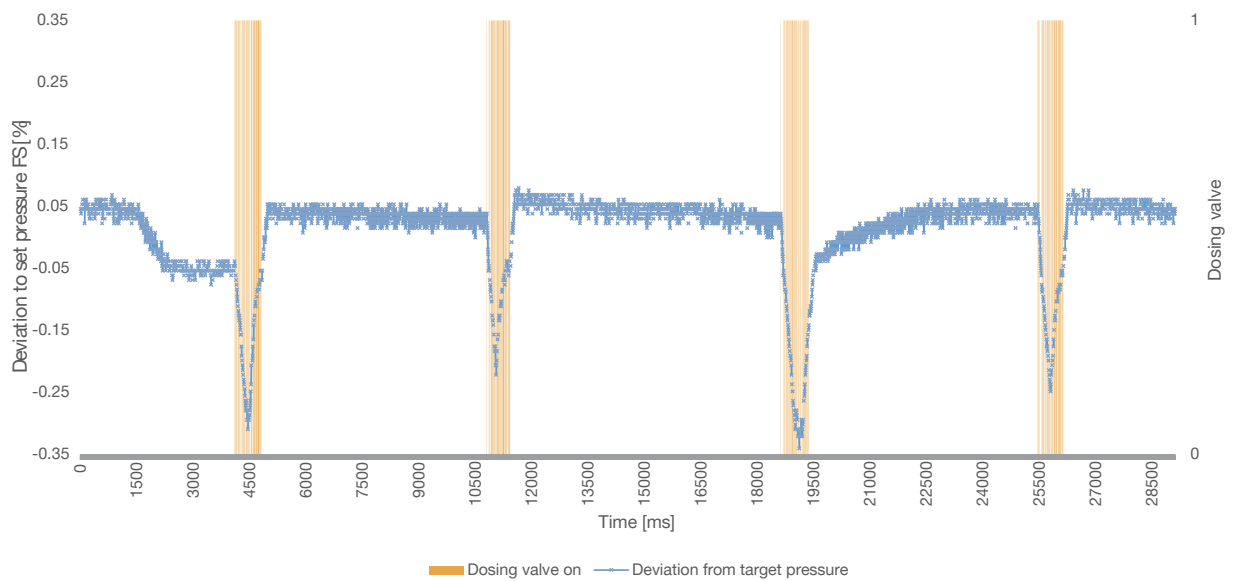

Dosing example varying target pressure

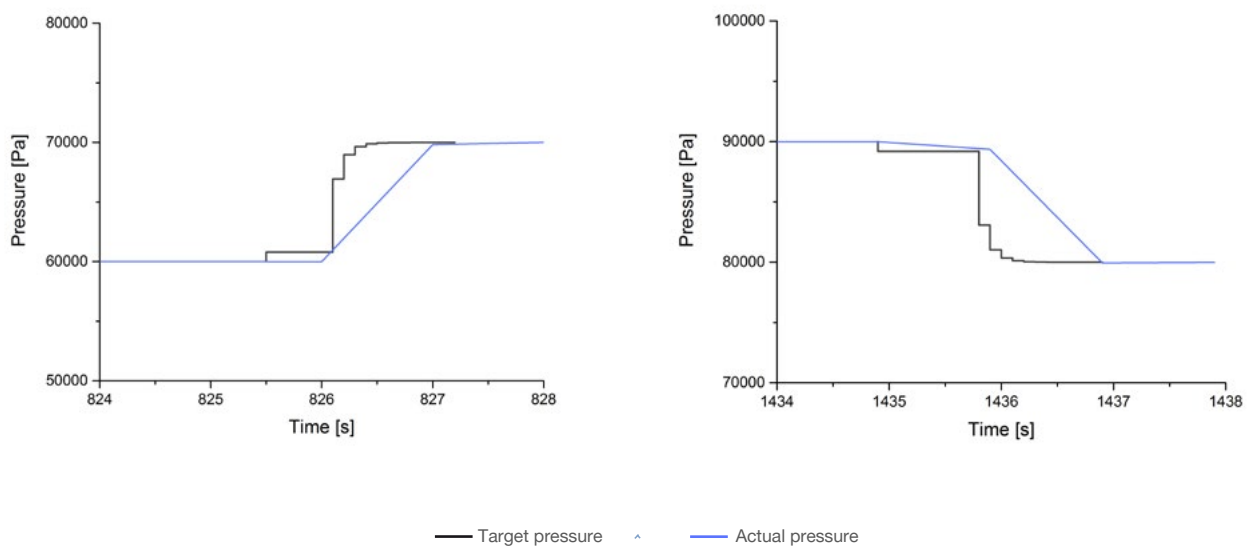

DTS 1000398869 EN Version: - Status: RL (released | freigegeben | validé) printed: 20.08.2019

5.2. Flow characteristic

Flow rate of versions with atmosphere at the outlet

Conditions:

- Proportional valve is fully open
- No back pressure, only the atmosphere at the outlet

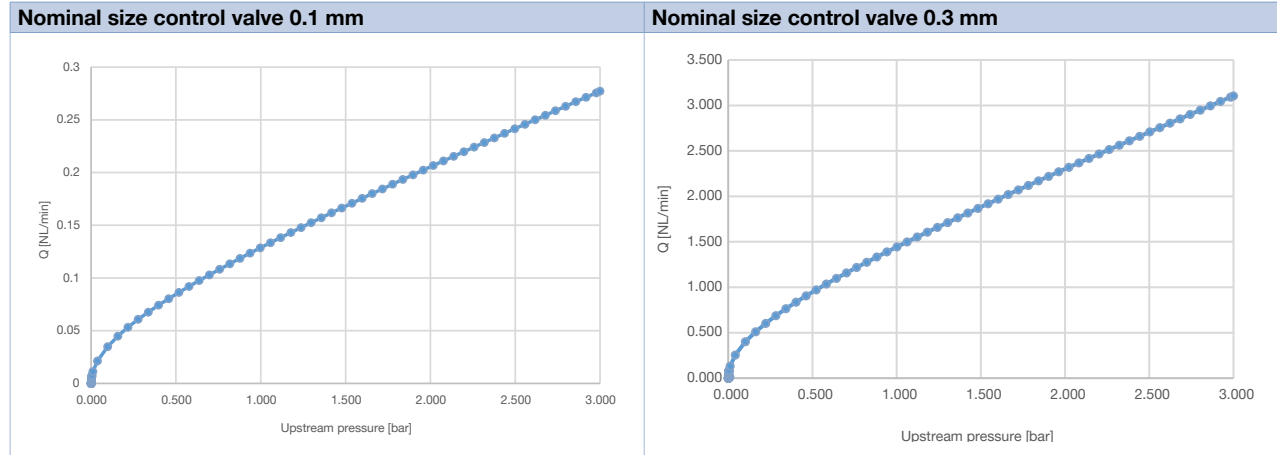

Flow rate of versions with pressure ratio “target pressure to supply pressure”

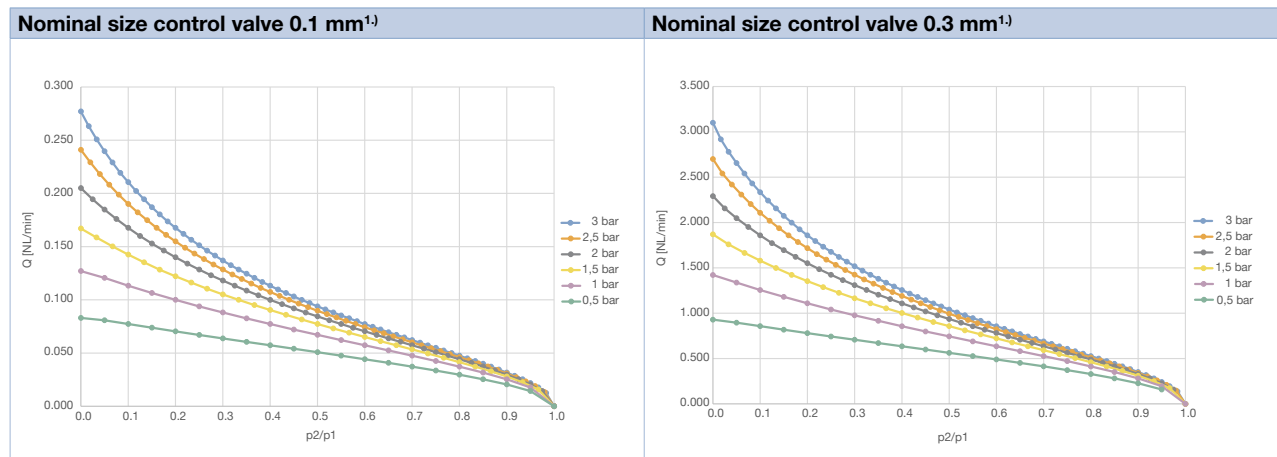

1.) p2 = target pressure; p1 = supply pressure

6. Ordering information

6.1. Bürkert eShop – Easy ordering and quick delivery



Bürkert eShop – Easy ordering and fast delivery

You want to find your desired Bürkert product or spare part quickly and order directly? Our online shop is available for you 24/7. Sign up and enjoy all the benefits.

[Order online now](#)

6.2. Bürkert product filter



Bürkert product filter – Get quickly to the right product

You want to select products comfortably based on your technical requirements? Use the Bürkert product filter and find suitable articles for your application quickly and easily.

[Try out our product filter](#)

6.3. Ordering chart

Note:

All electrical plugs are included in the scope of delivery.

Pressure range [bar (psi)]	Nominal size control valve ^{1.)} [mm]	Electrical connection	Article no.
0...0.35 (0...5)	0.1	Digital	318288
0...1 (0...14.5)	0.3	Digital	318290
0...2 (0...29)	0.3	Digital	318291

1.) Other versions on request

6.4. Ordering chart accessories

Description	Article no.
büS starter kit 	772426
Connector digital version (büS)	920299
Connector digital version (sensor supply/actuator)	920245
Gas/air pump SP 570 EC 12 V DC (250 mA); ≥2 l/min; ≥1000 mbar (14.5 Psi)	906327
Gas/air pump SP 600 EC-DV 12 V DC (400 mA); ≥3 l/min; ≥1300 mbar (18.85 Psi)	906379
Gas/air pump SP 620 EC-BL-DV 12 V DC (500 mA) ≥2.8 l/min; ≥1300 mbar (18.85 Psi); brushless	906380

Bürkert – Close to You

For up-to-date addresses
please visit us at
www.burkert.com

DTS 1000398869 EN Version: - Status: RL (released | freigegeben | validé) printed: 20.08.2019

