

---

## ABS flow booster SB 900 to 2500

---

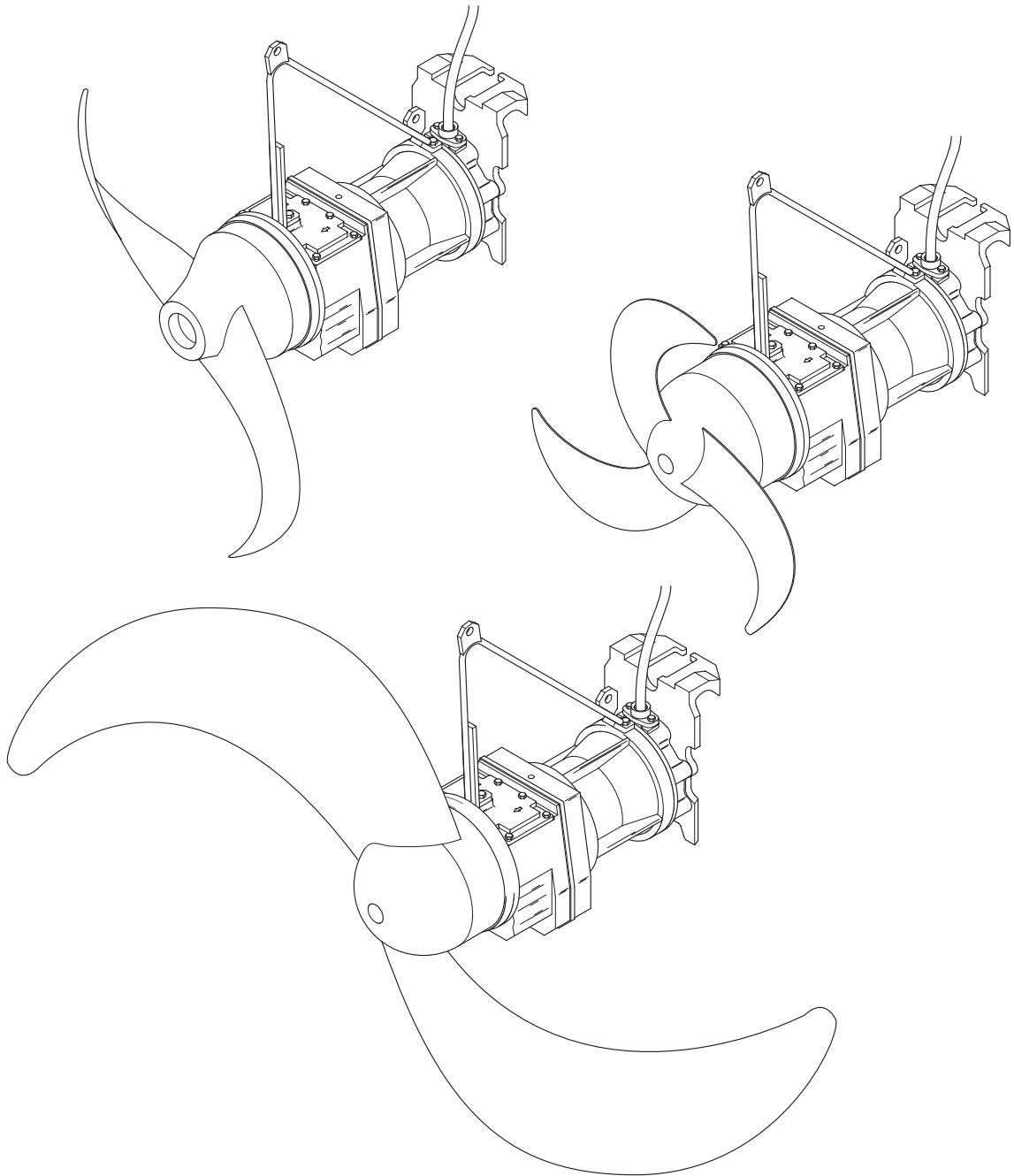

0580-0002

**Maintenance Instructions**

for ABS flow booster

SB 931 (50/60 Hz)	SB 1221 (50/60 Hz)	SB 1621 (50/60 Hz)	SB 1821 (50/60 Hz)
SB 932 (50/60 Hz)	SB 1222 (50/60 Hz)	SB 1622 (50/60 Hz)	SB 1822 (50/60 Hz)
SB 933 (50/60 Hz)	SB 1223 (50 Hz)	SB 1623 (50/60 Hz)	SB 1823 (50/60 Hz)
SB 934 (60 Hz)		SB 1624 (50 Hz)	SB 1824 (50/60 Hz)
		SB 1626 (50 Hz)	SB 1825 (50/60 Hz)
SB 2021 (50/60 Hz)	SB 2221 (50/60 Hz)	SB 2521 (50/60 Hz)	
SB 2022 (50/60 Hz)	SB 2222 (50/60 Hz)	SB 2522 (50/60 Hz)	
SB 2023 (50/60 Hz)	SB 2223 (50/60 Hz)	SB 2523 (50/60 Hz)	
SB 2024 (50/60 Hz)	SB 2224 (50/60 Hz)	SB 2524 (50/60 Hz)	
SB 2025 (50/60 Hz)	SB 2225 (60 Hz)	SB 2525 (50/60 Hz)	
SB 2026 (60 Hz)	SB 2226 (60 Hz)		

# Table of contents

<b>1</b>	<b>General</b> .....	<b>4</b>
1.1	Introduction .....	4
<b>2</b>	<b>Safety</b> .....	<b>5</b>
<b>3</b>	<b>Maintenance</b> .....	<b>5</b>
3.1	Removal .....	5
3.1.1	Removal (flow booster with lockable coupling system).....	5
3.1.2	Removal (flow booster with self adjusting coupling system).....	5
<b>4</b>	<b>Operating proplems</b> .....	<b>7</b>
<b>5</b>	<b>Checking the coupling system</b> .....	<b>7</b>
<b>6</b>	<b>Inspection intervals flow booster SB</b> .....	<b>8</b>
<b>7</b>	<b>Inspections</b> .....	<b>10</b>
7.1	Initial inspection.....	10
7.2	Check .....	11
7.3	Annual inpection.....	12
7.4	General overhaul.....	13
<b>8</b>	<b>Maintenance</b> .....	<b>14</b>
8.1	Checking/changing of the gearbox oil (All models) .....	14
8.2	Propeller removal/assembly .....	15
8.3	Mechanical seal removal/assembly .....	16
8.4	Oil filling and oil change (Old SB versions).....	19
8.5	Oil filling and oil change (Model 2006 with larger oil chamber).....	20
8.6	SD-ring (Solids-deflection-ring) removal/assembly .....	21

## 1 General

### 1.1 Introduction

Inspections carried through at regular intervals and preventive maintenance ensure trouble-free operation. For this reason the complete unit should be cleaned thoroughly on a regular basis, maintained and inspected. When doing this one has to take special care that all parts of the unit are in a good condition and that the operational security is guaranteed. **The inspection period is determined by the usage of the units!**

The ABS Service Organisation would be pleased to advise you on any special applications you may have.

The user of the unit must ensure that all maintenance, inspection or installation work is carried out by authorised and qualified skilled personnel. The user must also make sure that these personnel have carefully studied the Installation and Operating Instructions.

As a matter of principle all work on the unit should only be carried out while it is switched off. The method described in the Maintenance Instructions to shut down the unit must be complied with.

Units used for pumping or mixing of liquids, which could endanger health, must be decontaminated. Immediately after completion of the work all safety and protective devices must be refitted and reactivated.

Before recommencing operation all points listed under the section "Commissioning" in the Installation and Operating Instructions must be complied with.

These Maintenance Instructions contain basic information on the installation, operation and maintenance and should be followed carefully. For this reason it is essential that these instructions are read carefully before installation or commissioning not only by the installation crew, but also as by those who are responsible for operation or maintenance. The Maintenance Instructions should always be readily available at the location of the unit.



Safety Instructions which might cause danger to life in case of non-observance have been specifically highlighted with the general danger symbol.



The presence of a dangerous voltage is identified with this safety symbol.



This symbol indicates the danger of an explosion occurring.

**ATTENTION**      ***Appears at safety hints, the non-observance of which could damage the unit or affect its functioning.***

**NOTE**              ***Used for important pieces of information.***

Illustrations code, e.g. (3/2). The first digit refers to the figure no. and the second digit to the position in that figure.

## 2 Safety

The general and specific health and safety hints are described in detail in the separate booklet **Safety Hints**. If anything is not clear or you have any questions as to safety make certain to contact the manufacturer ABS.

## 3 Maintenance

**NOTE** *The ABS warranty conditions are only valid provided that any repair work has been carried out in ABS approved workshops and where original ABS spare parts have been used.*

### 3.1 Removal



Take note of the entire weight of the unit. The hoist and chain must be adequately dimensioned for the weight of the unit and must comply with the current valid safety regulations as well as good technical practice must be observed.



Do not stay or work in the swivel area of a suspended load!



The lifting hook height must take into consideration the entire height of the unit as well as the length of the lifting chain.

**ATTENTION** *When using a mechanical lifting tool (e.g. truck crane) or a tool with higher nominal load, special attention is required! Ensure that lifting power doesn't exceed 3000 N when flow booster gets stuck on guide tube!*

#### 3.1.1 Removal (flow booster with lockable coupling system)

In case of flow booster units with the **lockable** coupling system (see *Figure 2*) the coupling system must be unlocked before removal. (See *Figure 3 and 4*). Lift the flow booster (after unlocking the coupling system) with the aid of a hoist out of the tank and place it onto an even firm flat surface.

#### 3.1.2 Removal (flow booster with self adjusting coupling system)

Lift the flow booster units with **self adjusting** coupling system (see *Figure 1*) with the aid of a hoist out of the tank and place it onto an even firm flat surface.

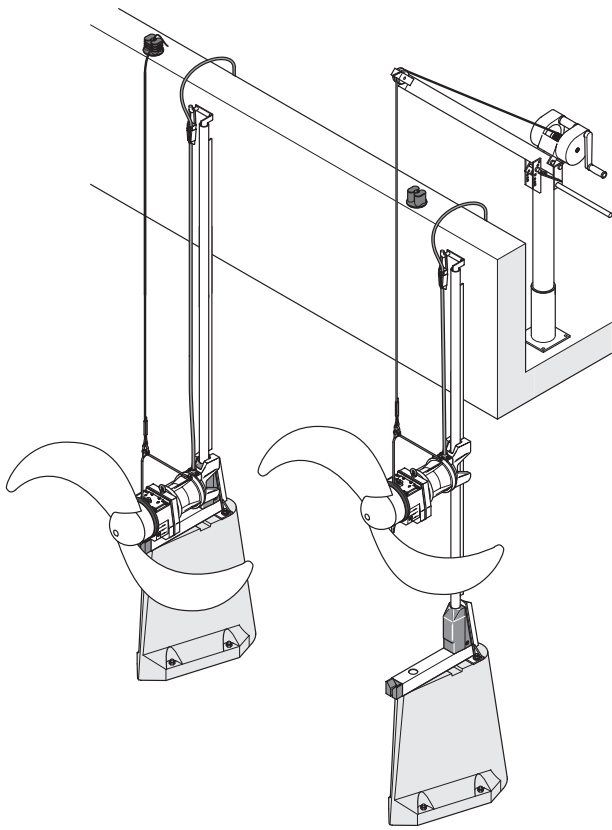

0579-0001

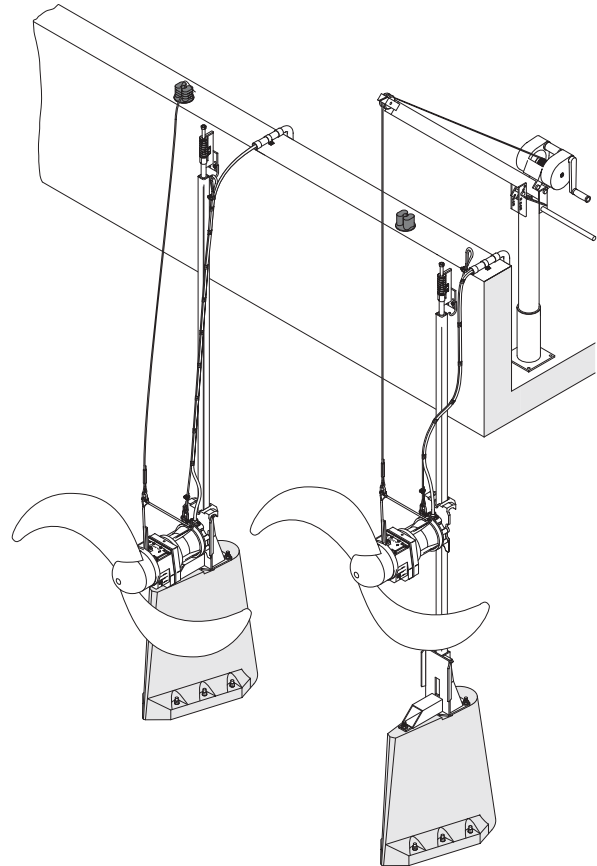

0579-0002

Figure 1 SB with self adjusting coupling system

Figure 2 SB with lockable coupling system

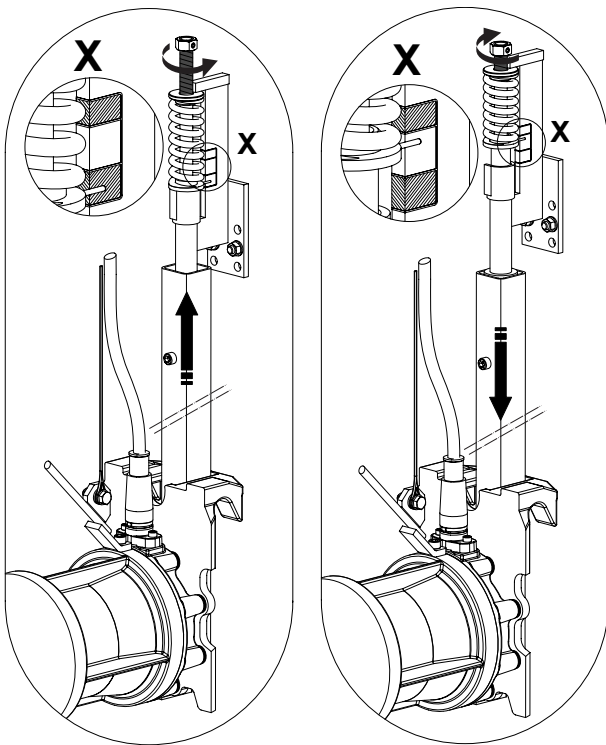
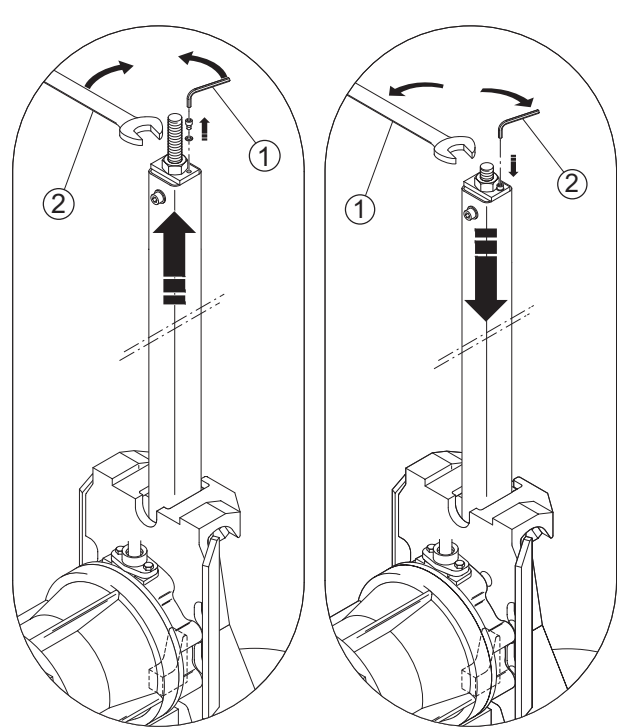

Figure 3 Locking/Unlocking of coupling system with fixed installation (Variant A)



0579-0003

0579-0004

Figure 4 Locking/Unlocking of coupling system with freestanding installation (Variant B)

## 4 Operating problems



The safety hints in the previous sections must be observed!

In addition to the prescribed maintenance and inspection periods an inspection of the unit must be carried out urgently if any unusual symptoms are observed such as heavy vibrations or uneven flow formation.

### Possible fault causes:

- Coverage of water over propeller is inadequate.
- Aeration in the propeller area.
- Wrong direction of rotation of the propeller.
- Roping or entanglement of material at the propeller or on the cable.
- Propeller is damaged.
- Flow booster is not correctly coupled or locked in position.
- Parts of the installation such as brackets or coupling parts are defective or have become loose.

In these cases the unit should be switched off immediately and inspected. If no fault cause is found or if the problem persists after correction of the apparent fault then the unit should be switched off. The same applies if the current overload in the control panel repeatedly trips, if the moisture sensor (DI) or thermal sensors are activated. Please contact your ABS service centre for assistance.

## 5 Checking the coupling system



The safety hints in the previous sections must be observed!

Under normal operating conditions the coupling and clamping mechanism of the flow booster cannot open, as it is a specially shaped clamped device. For safety reasons however, the coupling system must be checked for proper functioning every time it is coupled into position. A short test run should then be made.

- Switch off unit and ensure it cannot be inadvertently switched back on.
- Turn the tube holding screw counter clockwise (Variant "A") respectively clockwise (Variant "B") as far to the stop (see figure 3 respectively Figure 4).
- Raise the flow booster out of the tank with the hoist.

### **ATTENTION**      *The lifting rope should be tensioned exactly vertically!*

- Clean flow booster and power cable (see maintenance instruction below).
- Lower the flow booster until it connects into the coupling piece. Raise the flow booster once more about 20 cm and couple it again.

#### Variant "A"

- Turn the tube holding screw clockwise (see figure 3) so far until the indication pin is inside the green marking of the spring load indication device of the tube holder. If the indication pin is not inside the green marking the unit has not coupled in a proper manner!

#### Variant "B"

- Turn the tube holding screw counter clockwise (see figure 4) and tighten it with a tightening torque of 80 Nm. To secure the holding screw, screw in the socket head screw. If the tightening torque of 80 Nm of the tube holding screw will not be reached the unit has not coupled in a proper manner!

### Variant “A and B”

#### Possible causes:

- The hoist is not set up correctly. Rope is not exactly vertical.

**Measure:** Adjust the boom position of the hoist or crane.

- Other units present are causing uneven flow and preventing the unit from coupling correctly.

**Measure:** Switch off the other units.

- The coupling piece is clogged with dirt or roped material. This can happen after longer periods of non-usage.

**Measure:** Clean with a strong jet of water.

- Repeat the coupling procedure until the unit has coupled in a proper manner.

### Variant “A”

- Turn the tube holding screw clockwise so far until the indication pin is inside the green marking of the spring load indication device of the tube holder.

### Variant “B”

- Tension the tube holder screw to **80 Nm** and lock it.

### Variant “A and B”

- Carry out test run as described in *chapter 6. “Commissioning”* of the Installation and Operating Instructions.

**ATTENTION** *The flow booster should not be operated if symptoms such as fluctuating Ampere readings, uneven flow formation, air flute formation or vibration occur!*

Please contact your responsible ABS Service Organisation.

## 6 Inspection intervals flow booster SB



The safety hints in the previous sections must be observed!

The inspections intervals needed depend on the operation conditions on site. The classification is divided into **operating classes 1 to 4**.

The evaluation of the operating conditions and the operating class should be made in advance, during the project engineering with reference to the known regulatory environment and parameters. After that the preliminary operating class can be selected.

During commissioning the real operation conditions should be established. These should be checked again during the initial inspection (after 500 or 100 operating hours). The final evaluation regarding the operating class should then be made.

### Difficult operating conditions

- A high proportion of fibrous matter in the medium.
- Turbulent flows caused by simultaneous operation of aerators, deep tanks, unfavourable tank geometry or structures in the tank which affect the flow.
- Aggressive or corrosive liquids.

After assessment of the operating conditions present, the operating class is assigned. **If one or more of the conditions mentioned above are causing difficult operating conditions, then the assessment of the operating classes should be class 3 or 4.** The inspections should be carried out as required. If you have any doubts or questions please contact the ABS Service Organisation.



Operating class	Evaluation
1	Good conditions
2	normal conditions
3	heavy duty conditions
4	critical conditions

**prescribed inspection and maintenance intervals SB**

Operating class 1 and 2	Operating class 3 and 4
<p align="center">After 500 operating hours            "1. Initial Inspection"            X-1 to X-8            "Check of operating conditions"            X-9</p>	<p align="center">After 100 operating hours            "1. Initial Inspection"            X-1 to X-8            "Check of operating conditions"            X-9</p>
	<p align="center">After 3 month            "Check"            X-3 to X-8</p>
	<p align="center">After 6 month            "Check"            X-3 to X-8</p>
	<p align="center">After 9 month            "Check"            X-3 to X-8</p>
<p align="center">After 12 month            "Annual inspection"            X-1 to X-8; Y-1 to Y-5</p>	<p align="center">After 12 month            "General overhaul"            X-1 to X-8; Y-1 to Y-5; Z-1 to Z-3</p>
	<p align="center">After 15 month            "Check"            X-3 to X-8</p>
	<p align="center">After 18 month            "Check"            X-3 to X-8</p>
	<p align="center">After 21 month            "Check"            X-3 to X-8</p>
<p align="center">After 24 month            "Annual inspection"            X-1 to X-8; Y-1 to Y-5</p>	<p align="center">After 24 month            "General overhaul"            X-1 to X-8; Y-1 to Y-5; Z-1 to Z-3</p>
	<p align="center">After 27 month            "Check"            X-3 to X-8</p>
	<p align="center">After 30 month            "Check"            X-3 to X-8</p>
	<p align="center">After 33 month            "Check"            X-3 to X-8</p>
<p align="center">After 36 month            "General overhaul"            X-1 to X-8; Y-1 to Y-5; Z-1 to Z-3</p>	<p align="center">After 36 month            "General overhaul"            X-1 to X-8; Y-1 to Y-5; Z-1 to Z-3</p>

## 7 Inspections



The safety hints in the previous sections must be observed!

### 7.1 Initial inspection

After 500 or 100 operating hours, depending on the operating class, the flow booster should undergo a thorough initial inspection (X). The detailed inspection tasks listed below should be carefully carried out.

- X-1** Checking the current consumption via the Ampere meter.
- X-2** Functional testing of the monitoring devices.
- X-3** Decouple the unit and raise it. Then clean it.
- X-4** Visual inspection of the shackles and all elements of the lifting equipment.
- X-5** Checking propeller and SD-ring.
- X-6** Checking the tension of the strain relief of the power cable.
- X-7** Check that the motor and monitoring cables are not damaged.
- X-8** Checking the functioning of the coupling system (**Variant "B" tighten tube holding screw with 80 Nm!**).
- X-9** **Assessment of the operating conditions.**

During normal operation the current consumption should be constant; occasional current fluctuations are caused by the constitution of the material being mixed.

- 
- X-1** Checking the current consumption via the Ampere meter
- 

**Measure:** If the current consumption is too high for a longer period during normal operation please contact your responsible ABS Service Organisation.

---

- X-2** Functional testing of the monitoring devices
- 

Part of the initial checking should include a functional test of all monitoring devices. For these functional tests the unit must have cooled down to the ambient temperature. The electrical connections of the monitoring device must be disconnected at the control box. These measurements are carried out through by means of an ohmmeter at the respective cable ends.

**Measure:** In case of any functional problems on the monitoring devices please contact your responsible ABS Service Organisation.

---

- X-3** Decouple the unit and raise it. Then clean it
- 

Disconnect the unit from the mains and ensure it cannot be inadvertently switched back on. (Turn the tube fixing screw anti clockwise until reaches the stop position). Raise the flow booster out of the tank and clean it.

**Measure:** Defective or worn parts should be replaced. If necessary contact your responsible ABS Service Organisation.

---

- X-4** Visual inspection of the shackles and all elements of the lifting equipment
- 

Lifting equipment like hoists, shackles and all elements of the lifting equipment must undergo a visual examination at regular intervals for wear and corrosion.

**Measure:** Defective or worn parts should be replaced. If necessary contact your responsible ABS Service Organisation.

---

- X-5** Checking propeller and SD-ring
- 

The propeller and SD-ring should be carefully inspected. The propeller may show spots of rupture and wear due to strongly abrasive or aggressive mixing material. In either case the flow formation is reduced considerably and the propeller must be replaced. The solids-deflection-ring must also be checked for excessive wear and, if necessary, it must be exchanged.

**Measure:** Defective or worn parts should be replaced. If necessary contact your responsible ABS Service Organisation.

---

#### **X-6** Checking the tension of the strain relief of the power cable

The plastic rope for the strain relief of the motor connection cable should also be checked. It should be under light tension. If the tension has become lost, it could allow the motor cable to swing loose and become damaged.

**Measure:** If the plastic rope for the strain relief of the motor cable has become loose, it must be retensioned. (see *Installation and Operating Instructions Chapter 5, Figure 13*). Do this by opening the upper rope clamp, form a new loop and retighten the clamp. The rope is suspended from the cable hook so it is under light tension.

---

#### **X-7** Check that the motor and monitoring cables are not damaged

In special application cases (for example if the medium is heavily polluted with fibrous or solid material) the motor cables should be cleaned of any fibrous material (deposits or roped material). In addition the cables should be checked for any damage to the insulation such as scratches, fissures, bubbles or crushing.

**ATTENTION** *Damaged motor or control circuit cables must be replaced in all cases.*

**Measure:** Please contact your responsible ABS Service Organisation.

---

#### **X-8** Checking the functioning of the coupling system

The tight fit of the bracket and the proper function of the coupling system have to be checked. In case of **Variant "A"** it must be ensured that the indication pin of the spring load indication device is inside the green marking. In case of **Variant "B"** especially the prescribed tightening torque of the tube holding screw (80 Nm) has to be checked. (For detailed hints see chapter 5 "Checking the coupling system").

**Measure:** If any parts have become loose or are not longer tightly fastened or if the function is affected in any way please contact the ABS Service Organisation.

## **7.2 Check**

**For units with operating classes 3 or 4 a check must be carried out every 3 month.**

**X-3** Decouple the unit and raise it. Then clean it.

**X-4** Visual inspection of the shackles and all elements of the lifting equipment.

**X-5** Checking propeller and SD-ring.

**X-6** Checking the tension of the strain relief of the power cable.

**X-7** Check that the motor and monitoring cables are not damaged.

**X-8** Checking the functioning of the coupling system (**Variant "B" tighten tube holding screw with 80 Nm!**).

### 7.3 Annual inspection

- X-1** Checking the current consumption via the Ampere meter.
- X-2** Functional testing of the monitoring devices.
- X-3** Decouple the unit and raise it. Then clean it.
- X-4** Visual inspection of the shackles and all elements of the lifting equipment.
- X-5** Checking propeller and SD-ring.
- X-6** Checking the tension of the strain relief of the power cable.
- X-7** Check that the motor and monitoring cables are not damaged.
- X-8** Checking the functioning of the coupling system (**Variant "B" tighten tube holding screw with 80 Nm!**).

During the annual inspection the following checks should also be carried out.

- Y-1** Insulation resistance check.
- Y-2** Check the gearbox oil.
- Y-3** Check the lubricating oil *as per section 8.5* (only for model 2006).
- Y-4** Check that all bolt and nuts are tightened with the correct torque.
- Y-5** Repair any paint damage.

---

#### **Y-1** Insulation resistance check

---

The insulation resistance of the motor winding should be measured once a year. If the insulation resistance is not at the correct level, moisture might have entered the motor.

**Measure:** Please contact your responsible ABS Service Organisation. The unit must be taken out of operation and should not be started again!

---

#### **Y-2** Check the gearbox oil

---

Once a year the gearbox oil should be checked (see chapter 8.1 Checking/changing of the gearbox oil). Check if there is an emulsion of oil and water present.

**ATTENTION** *After the oil infill and oil drain screws on the gearbox have been closed off they and the surrounding area must be degreased and then carefully repainted.*

**Measure:** If water is found in the gearbox then the oil must always be replaced. In this case it is essential that you contact your responsible ABS Service Organisation as the probable cause is leakage in the gearbox. The unit should not be switched back on.

---

#### **Y-3** Check the lubricating oil *as per section 8.5* (only for model 2006)

---

Once a year the units of the new generation (from 01.2006) should undergo a check on the lubricating oil levels. (See Section 8.5) Check also if there is an emulsion of oil and water present.

**ATTENTION** *After the oil infill and oil drain screws on the gearbox have been closed off they and the surrounding area must be degreased and then carefully repainted.*

**Measure:** If water is found in the oil the mechanical seal must always be replaced. (See Section 8.3) In this case it is essential that you contact your responsible ABS Service Organisation. The unit should not be switched back on.

---

#### **Y-4** Checking of the tightening torques of the screws and nuts

---

For safety reasons we recommend checking once a year (or after 8000 operating hours) that the screws of the coupling bracket and the propeller fixing are correctly tightened.

**ATTENTION**

**Ensure that the fitting position and tightening torque of the Nord-Lock® securing washers is correct as in Figure 5 and table for tightening torque!**

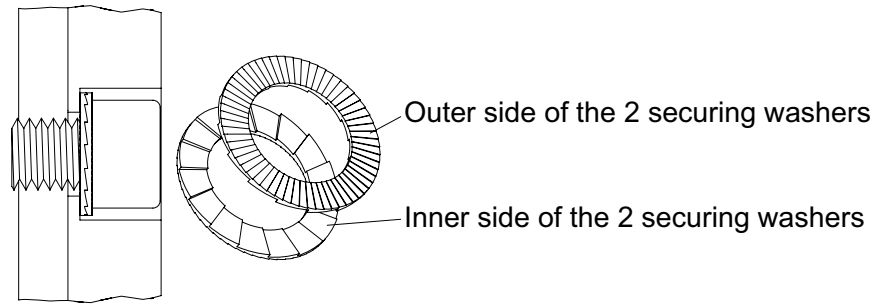

Figure 5 Correct fitting position of the Nord-Lock® securing washers

Tightening torque in Nm for:	M6	M8	M10	M12	M16	M20	M24
ABS stainless steel screws	6.9	17	33	56	136	267	460

Tube holder screw: 80 Nm in case of Variant “B”

**Measure:** Open the screws and then retighten using the correct torques.

---

**Y-5** Repair any paint damage

Once a year, thoroughly clean the unit and check for any paint damage. Any defects should be repaired.

**7.4 General overhaul**

- X-1** Checking the current consumption via the Ampere meter.
- X-2** Functional testing of the monitoring devices.
- X-3** Decouple the unit and raise it. Then clean it
- X-4** Visual inspection of the shackles and all elements of the lifting equipment.
- X-5** Checking propeller and SD-ring.
- X-6** Checking the tension of the strain relief of the power cable.
- X-7** Check that the motor and monitoring cables are not damaged.
- X-8** Checking the functioning of the coupling system (**Variant “B” tighten tube holding screw with 80 Nm!**).
- Y-1** Insulation resistance check.
- Y-2** Check the gearbox oil.
- Y-3** Check the lubricating oil *as per section 8.5* (only for model 2006).
- Y-4** Check that all bolt and nuts are tightened with the correct torque.
- Y-5** Repair any paint damage.

In addition to the annual inspection the following maintenance work should be carried out:

- Z-1 Changing the gearbox oil.
  - Z-2 Changing the power cables.
  - Z-3 Changing the mechanical seal and the lubricating oil.
- 
- Z-1 Changing of the gearbox oil
- 

Changing the gearbox oil is described in *chapter 8.1 Checking/changing of the gearbox oil*.

**Measure:** Due to the design of the unit special technical knowledge is required in order to be able to change the gearbox oil. If in doubts, please contact your ABS Service Organisation.

---

#### Z-2 Changing the power cable

---

We strongly recommend that the power cable and the seals at the cable inlet be replaced.

**Measure:** Due to the design of the unit special technical knowledge is required in order to be able to change the power cable. If in doubts, please contact your ABS Service Organisation.

---

#### Z-3 Changing the mechanical seal and the lubricating oil

---

We strongly recommend that the mechanical seal and the lubricating oil be replaced.

**Measure:** Due to the design of the unit special technical knowledge is required in order to be able to change the mechanical seal. If in doubts, please contact your ABS Service Organisation.

## 8 Maintenance



The safety hints in the previous sections must be observed!

### 8.1 Checking/changing of the gearbox oil (All models)

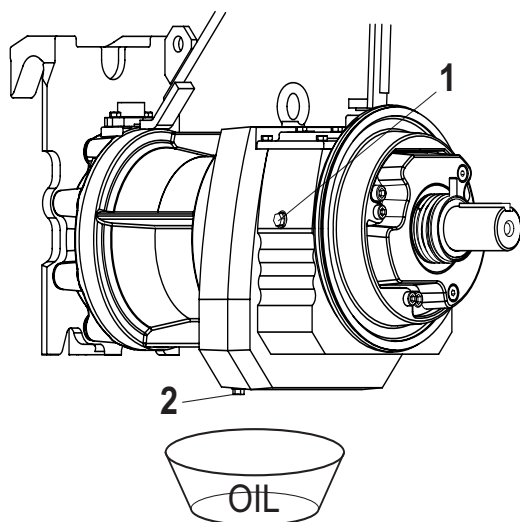

0579-0005 **Filling quantity of the gearbox oil:**

**2,4 l +/- 0,1 l**

**Approved gearbox oils:**

Klüber SYNTHESO D 220 EP

Tribol 800/220

Shell Tivela Öl WB

Mobil Glygoyle 30

BP Enersyn SG-XP 220

Aral Degol GS 220

Figure 6 Checking/changing of gearbox oil

#### Draining of the gearbox oil:



When carrying out the oil change the regulations for oil usage must be observed. Waste oil must be disposed of in a proper manner.



As there may be a pressure build-up in the gearbox care should be taken when removing the oil drain-or-fill screw. For this reason the screws should be covered with a cloth while removing.

- Open oil fill screw (6/1) carefully and release pressure if necessary.
- Screw out the oil drain screw (6/2) and release the oil.

#### Refilling the gearbox oil:

**ATTENTION**      *The listed filling quantity should be strictly observed. Otherwise the gearbox might be damaged!*

After the oil infill and oil drain screws on the gearbox have been closed off they and the surrounding area must be carefully degreased and then repainted.

## 8.2 Propeller removal/assembly

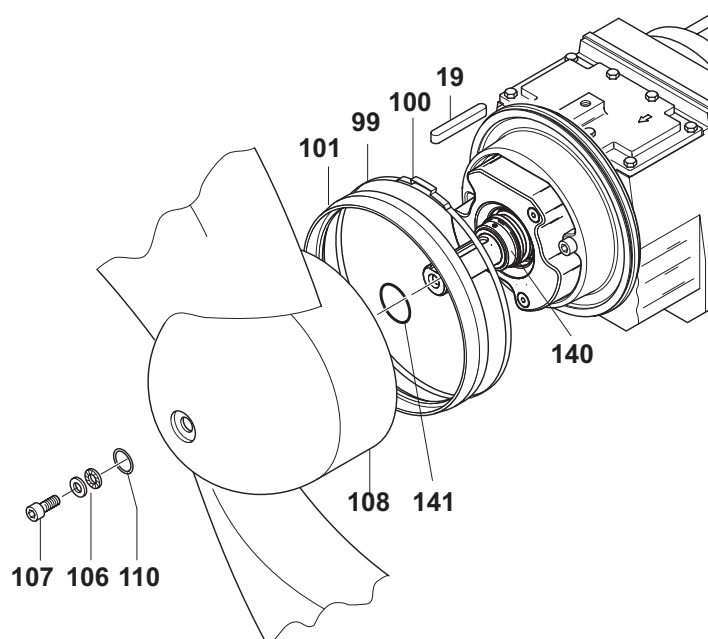

Figure 7 Propeller removal/assembly

#### Propeller dismantling:

**NOTE**      *The fixing strap (7/99) for the SD-ring (7/101) and the SD-ring itself does not have to be dismantled when removing or changing the propeller!*

- Remove propeller fixing screw (7/107) and withdraw the propeller (7/108).

**NOTE**      *Wear grooves may be visible at the circumference of the propeller hub, in the area where it overlaps with the solids-deflection-ring. These are normal signs of usage and have no negative effect on the operation. This means that it is not necessary to change the hub when changing the solids-deflection-ring.*

**ATTENTION**      *Observe the storage instructions (for the propeller) Section 3.3 of the Installation and Operating Instructions!*

#### Propeller assembly:

- Lightly grease the propeller boss and shaft end. Check key (7/19) for wear or damage and replace if necessary.
- Place a new seal (7/141) on the propeller shaft and place into the groove of the fixing ring (7/140).

- If necessary, fit a new SD-ring (7/101) as *per section 8.6* and fix in position with a new clamping ring (7/99) and new clamp (7/100).
- Carefully press on the propeller (7/108) and fit a new seal (7/110).
- Press on the securing rings (7/106) in the correct installation location (see *Figure 5*).
- Tighten the propeller fixing screw (7/107) with a **torque of 63 Nm**.

### 8.3 Mechanical seal removal/assembly

**ATTENTION** *Due to the design of the unit, the lubricating oil in the older versions of the SB can only be released after partial dismantling of the mechanical seal (rotating part 8/60.1)! (See section 8.4)*

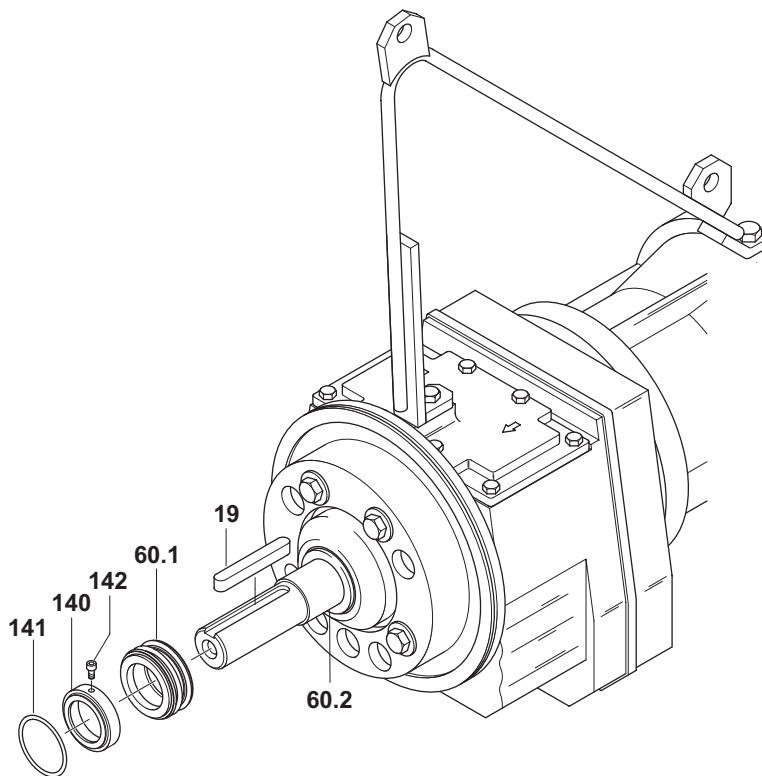

Figure 8 Mechanical seal removal/assembly

#### Removal of the mechanical seal:

- Press the key out of the keyway on the shaft (8/19).
- Withdraw the lip seal from the shaft (8/141).
- Open screw (8/142) at the fixing ring (8/140) and withdraw the fixing ring off the shaft.

**NOTE** *The flow booster should be set up vertically (see *Figure 11*) so that the oil does not gush out of the unit when the rotating part of the mechanical seal is removed.*

- Place flow booster vertically (as shown in *Figure 11*) and ensure that it cannot topple over.
- Have a collection vessel handy (min. 0.5 l).
- Carefully withdraw the rotating part of the mechanical seal (8/60.1) from the shaft with a light rotating motion. When doing this, cover or hold with a cloth to allow the release of any pressure which may be in the oil chamber.

**ATTENTION** *Changing the oil where necessary is carried out in accordance with section 8.4/8.5.*



**NOTE**

*If only the lubricating oil is being checked or changed, then the stationary part of the mechanical seal (8/60.2) need not be removed from the seal holding plate!*

The fixed stationary ring (8/60.2) is inserted into the seal holding plate of the gearbox with a profile seal. The fixed ring can be removed if necessary e.g. if it needs to be replaced by proceeding carefully as follows:

- Carefully press out the fixed ring (8/60.2) by exerting pressure simultaneously using two small screwdrivers.

**ATTENTION**

*After removal of the fixed ring we recommend for security reasons (even if no damage is visible) that the entire mechanical seal be replaced!*

**Assembly of the mechanical seal:**
**ATTENTION**

*When assembling the mechanical seal it is essential to proceed carefully and under clean conditions. Otherwise damage during assembly or subsequent failure in operation may result.*

In particular take special care when fitting and pressing home the fixed ring that it is not tilted. When pressing it home over the seal surface use a suitably dimensioned plastic tube (see Figure 9) with a perfectly flat surface. The inner diameter should be such that it slides closely over the shaft end. This will prevent tilting and damage to the sliding surfaces!

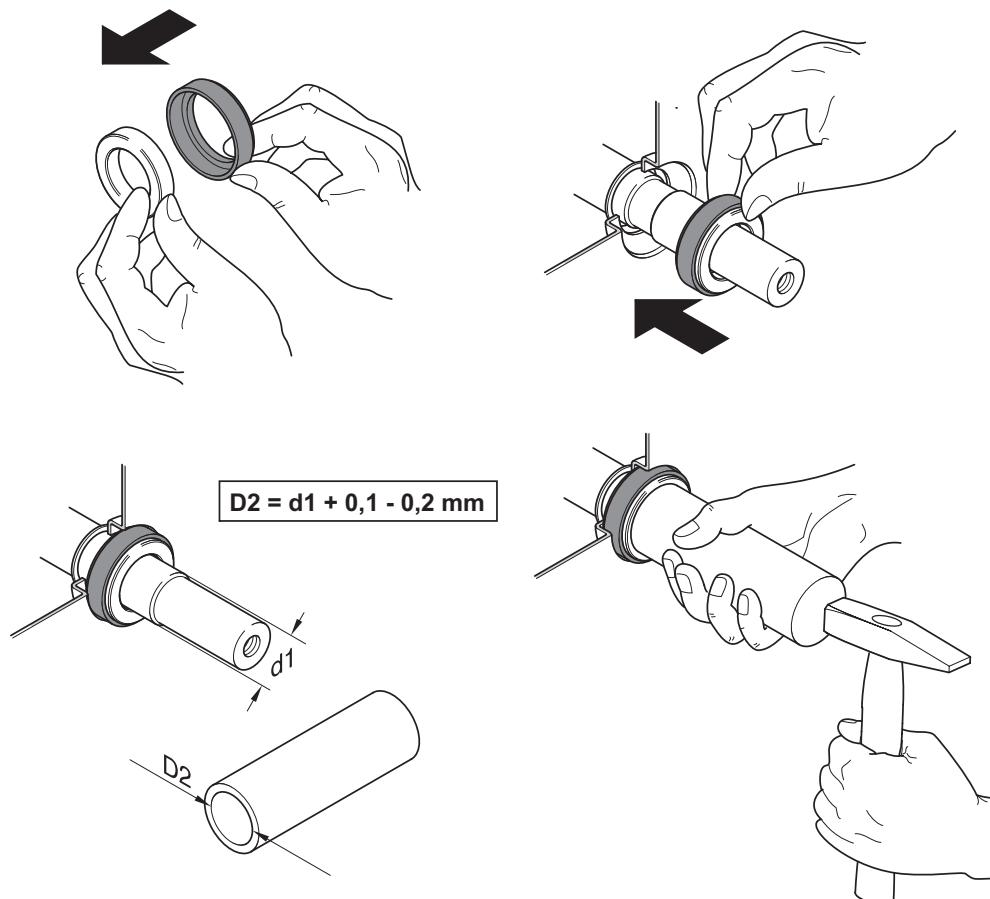

Figure 9 Fitting of the fixed ring

**NOTE**

*While the illustration Figure 9 shows the fitting of the profile seal, in most cases it is already fitted to the fixed ring.*

- Lubricate seal and sliding surface of the fixed ring lightly with some lubricating oil.
- Press fixed ring with profile seal over the shaft end and press fully home into the seating in the seal holding plate using a suitable plastic tube.

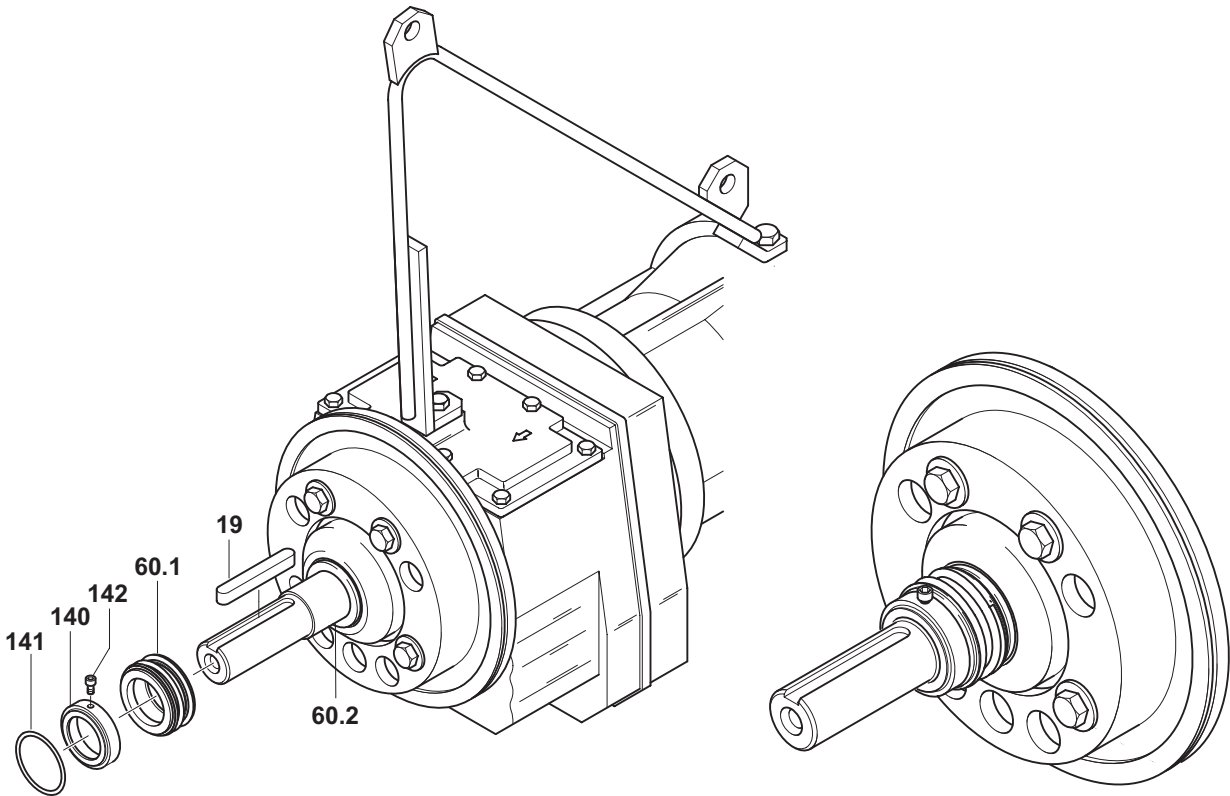

Figure 10 Assembling of the mechanical seal

**ATTENTION** *The oil chamber must always be filled with new lubricating oil before fitting the rotating part of the mechanical seal. (10/60.1). The method for filling in the oil is described in detail in sections 8.4/8.5.*

- Smear a film of lubricating oil on the sliding surfaces and the rubber bellows (internally) of the rotating part of the mechanical seal (10/60.1).

**ATTENTION** *In order to avoid possible damage to the rubber bellows of the mechanical seal, the chamfer on the shaft end as well as the step to the mechanical seating and the keyway groove should be carefully deburred. Any burrs must be removed before assembling the seal!*

- Place the rotating part of the mechanical seal (10/60.1) carefully over the shaft end and shaft step until both sliding faces are in contact.
- Slide the fixing ring (10/140) on the shaft and press fully home against the spring bellows of the seal. Fix the ring in this position with screw (10/142).

**ATTENTION** *Ensure the correct positioning of the fixing ring (see detailed illustration Figure 10). The groove for the seal has to show into the direction of the shaft end.*

#### 8.4 Oil filling and oil change (Old SB versions)



The regulations covering usage of oils and greases must be complied with. These materials should be disposed of in accordance with regulations!

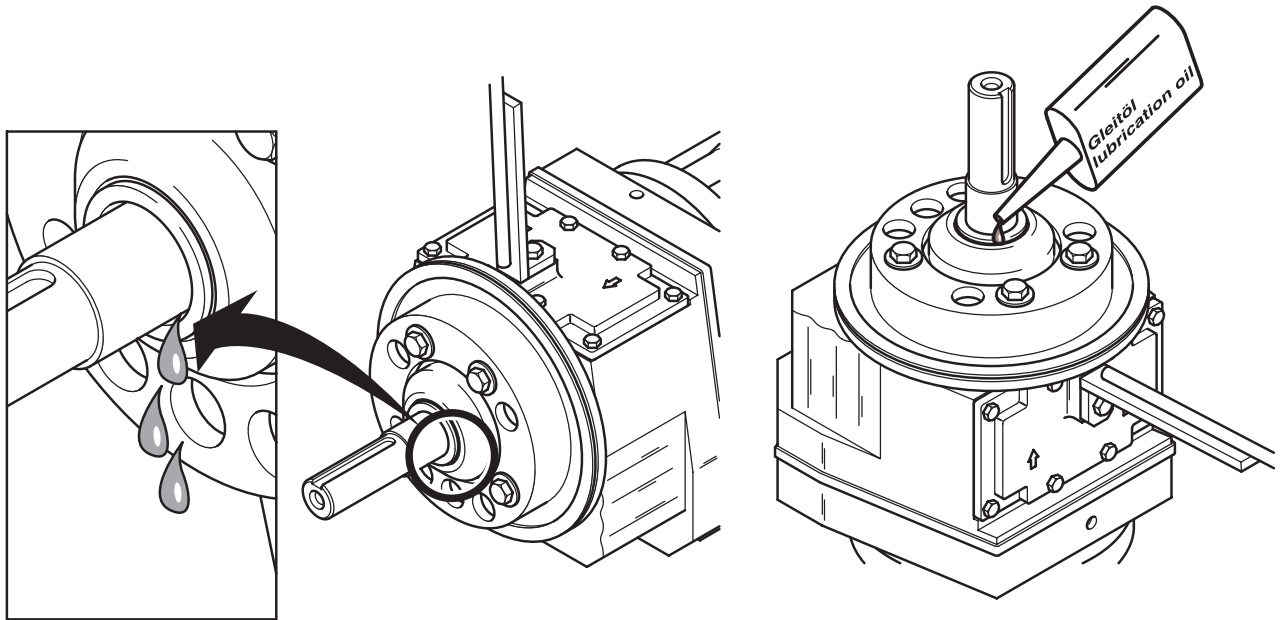

0576-0010

Figure 11 Oil filling and oil change



As there is a possibility that the oil chamber is pressurised, care should be taken when removing the rotating part of the mechanical seal. This area should be covered with a suitable cloth!

**ATTENTION** Due to the design of the unit, the lubricating oil can only be released after partial dismantling of the mechanical seal (rotating part) (see section 8.3).

##### Releasing the lubricating oil:

- Release the oil along the shaft gap as shown in *Figure 11* into a suitable container (min. 0,5 l). When doing this tilt the motor and gearbox unit sufficiently to allow the lubricating oil to fully flow out.

##### Filling with lubricating oil:

- To fill with new oil place the unit vertically on the bracket with the shaft end pointing upwards. Ensure it cannot topple over.
- The new oil is filled in along the gap between fixed ring and the shaft in a similar manner to when releasing the oil (see *Figure 11*).

**Lubricating oil filling quantity:** 0.05 Litre = 50 cm<sup>3</sup> (+/- 10%)

**Lubricating oil specification:** ISO VG class 46 (DIN 51519)

- Fit the mechanical seal as described in *section 8.3* in order to close up and seal the lubricating oil chamber.

## 8.5 Oil filling and oil change (Model 2006 with larger oil chamber)

**NOTE** *In the case of the newer SB models with the larger oil chamber, it is not necessary to dismantle the mechanical seal to check or change the oil!*

- Remove propeller as per section 8.2.

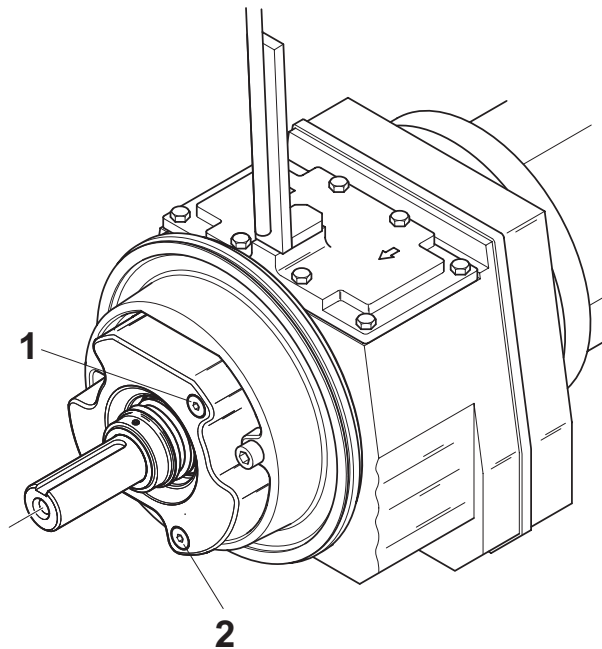

0579-0011

Figure 12 Oil filling and oil change

- Carefully open oil fill screw (12/1) and allow the pressure to escape.
- Remove oil fill screw (12/2) and release the oil.

**Lubricating oil filling quantity:** 0.4 Litre = 400 cm<sup>3</sup> (+/- 10%)

**Lubricating oil specification:** ISO VG class 46 (DIN 51519)

## 8.6 SD-ring (Solids-deflection-ring) removal/assembly

**NOTE** In Figure 13 the exchange of the SD-ring on a RW mixer motor is shown. The installation on the flow booster is similar.

### Dismantling:

The SD-ring (13/1) can become worn in usage. Inspect it and if necessary replace it.

- Cut off the clamp (13/4) and dismantle the fixing strap (13/3).
- Pull the SD-ring (13/1) carefully out of the groove of the motor cover (13/2) and strip back.

### Assembly:

- When refitting the SD-ring (13/1), this should be pressed around its circumference by hand as shown in *Figure 13* and pressed down into the groove of the motor cover.
- Fix the fixing strap (13/3) with a new clamp (13/4) with the aid of a special tool (BAND-IT clamping tool) part. no. 96990340.

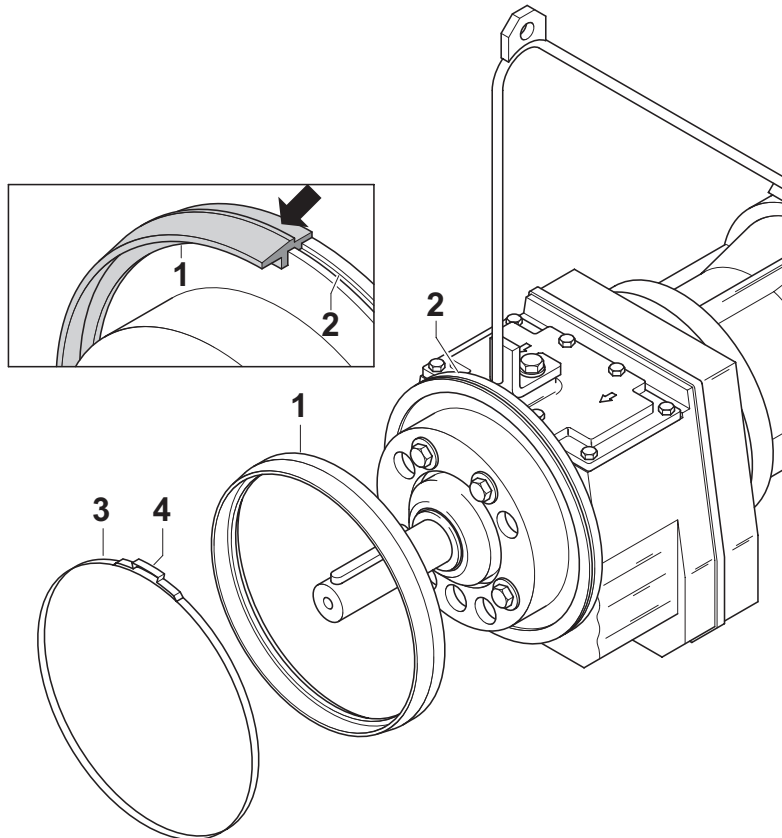

Figure 13 Solids-deflection-ring removal/assembly

**Report on planned inspection and maintenance carried out at the recommended frequency for units of operating classes 1 and 2**

Manufacturer: ABS Production Lohmar GmbH  
 Scheiderhöher Strasse 30-38  
 53797 Lohmar, Germany

Year of production: \_\_\_\_\_ 1. Commissioned: \_\_\_\_\_

Serial no.: \_\_\_\_\_ Operating class: \_\_\_\_\_

Model type: \_\_\_\_\_ Verified and checked by: \_\_\_\_\_

Recommended inspection or maintenance	Maintenance interval after x operating hours or x month after 1. commissioning!	Maintenance or inspection work carried out	Remarks	Carried out on:	Signature/stamp
<b>1. Inspection</b>	After 500 hours	X-1 to X-8			
Annual inspection	After 12 month	X-1 to X-8; Y-1 to Y-5			
Annual inspection	After 24 month	X-1 to X-8; Y-1 to Y-5			
<b>General overhaul</b>	After 36 month	X1 to X-8; Y-1 to Y-5; Z-1 to Z-3			
Annual inspection	After 48 month	X-1 to X-8; Y-1 to Y-5			
Annual inspection	After 60 month	X-1 to X-8; Y-1 to Y-5			
<b>General overhaul</b>	After 72 month	X1 to X-8; Y-1 to Y-5; Z-1 to Z-3			
Annual inspection	After 84 month	X-1 to X-8; Y-1 to Y-5			
Annual inspection	After 96 month	X-1 to X-8; Y-1 to Y-5			
<b>General overhaul</b>	After 108 month	X1 to X-8; Y-1 to Y-5; Z-1 to Z-3			
Annual inspection	After 120 month	X-1 to X-8; Y-1 to Y-5			

**Report on planned inspection and maintenance carried out at the recommended frequency for units of operating classes 3 and 4**

Manufacturer: ABS Production Lohmar GmbH  
 Scheiderhöher Strasse 30-38  
 53797 Lohmar, Germany

Year of production: \_\_\_\_\_ 1. Commissioned: \_\_\_\_\_

Serial no.: \_\_\_\_\_ Operating class: \_\_\_\_\_

Model type: \_\_\_\_\_ Verified and checked by: \_\_\_\_\_

Recommended inspection or maintenance	Maintenance interval after x operating hours or x month after 1. commissioning!	Maintenance or inspection work carried out	Remarks	Carried out on:	Signature/stamp
<b>1. Inspection</b>	After 100 hours	X-1 to X-8			
Check	After 3 month	X-1 to X-8			
Check	After 6 month	X-1 to X-8			
Check	After 9 month	X-1 to X-8			
<b>General overhaul</b>	After 12 month	X1 to X-8; Y-1 to Y-5; Z-1 to Z-3			
Check	After 15 month	X-1 to X-8			
Check	After 18 month	X-1 to X-8			
Check	After 21 month	X-1 to X-8			
<b>General overhaul</b>	After 24 month	X1 to X-8; Y-1 to Y-5; Z-1 to Z-3			
Check	After 27 month	X-1 to X-8			
Check	After 30 month	X-1 to X-8			
Check	After 33 month	X-1 to X-8			
<b>General overhaul</b>	After 36 month	X1 to X-8; Y-1 to Y-5; Z-1 to Z-3			
Check	After 39 month	X-1 to X-8			
Check	After 42 month	X-1 to X-8			
Check	After 45 month	X-1 to X-8			
<b>General overhaul</b>	After 48 month	X1 to X-8; Y-1 to Y-5; Z-1 to Z-3			
Check	After 51 month	X-1 to X-8			
Check	After 54 month	X-1 to X-8			
Check	After 57 month	X-1 to X-8			
<b>General overhaul</b>	After 60 month	X1 to X-8; Y-1 to Y-5; Z-1 to Z-3			
Check	After 63 month	X-1 to X-8			
Check	After 66 month	X-1 to X-8			
Check	After 69 month	X-1 to X-8			
<b>General overhaul</b>	After 72 month	X1 to X-8; Y-1 to Y-5; Z-1 to Z-3			



| ABS Production Lohmar GmbH | Scheiderhöher Straße 30-38, D-53797 Lohmar, Germany |  
| Tel. +49 22 46 900 0 | Fax +49 22 46 900 200 | [www.absgroup.com](http://www.absgroup.com) |