

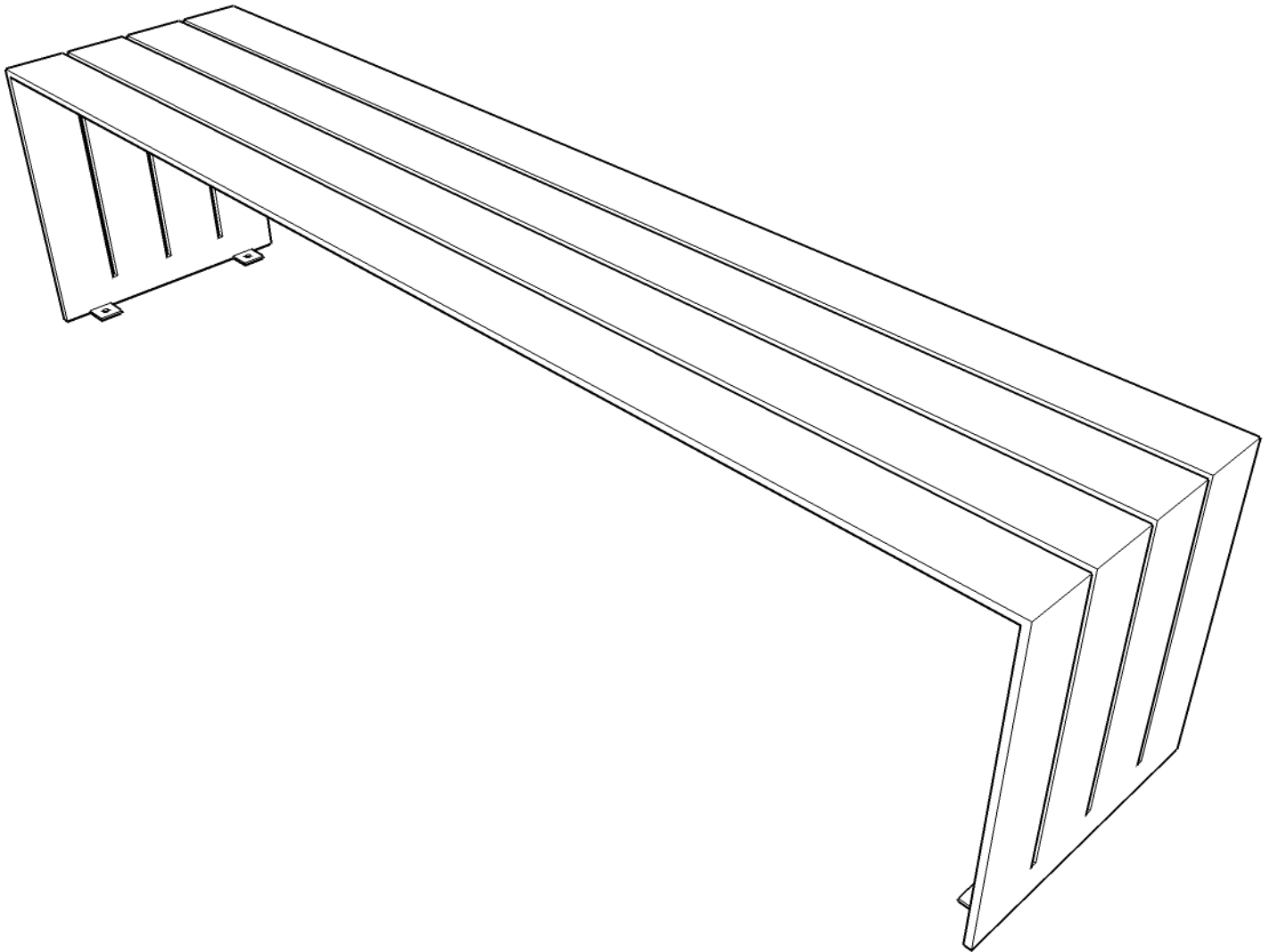

**Factoryfurniture**

## BLOC bench - steel

---



# Operation & Maintenance Manual

---

# Introduction

## Design

Design, shop drawings and development by Factory Furniture Ltd

## Manufacture

Factory Furniture manufactured components. Products are assembled in Factory workshops, checked and dispatched ready for installation. Replacement products or components thereof should be ordered direct from Factory Furniture Ltd

## Copyright

The design copyright for the product and drawing copyright remains the sole property of Factory Furniture Ltd

# General Specifications

## Bench

*Metric* length 1950mm | width 430mm | height 450mm\*

*Imperial* length 6' 5" | width 1' 5" | height 1' 6"

*Not including +100mm below ground level for sub-surface fix option*

**Approx Weight** 106kg

**Fixing Centres** 1890mm (6' 2½") x 300mm (12")

# Detailed Material & Finish Specifications

## Bench

- Manufactured from either stainless steel (satin polished) or mild steel (hot dip galvanised or polyester powder-coated (*powder coat colour grey as standard or to customer specification*)).
- Anchored with 4 no. zinc-coated M10 x 75mm sleeve anchors into fixing lugs (surface & sub-surface fixing options available)

# General Maintenance *(Recommended Schedule & Guidelines)*

## Daily/Weekly/Monthly *(or as adopted)*

Visual checks of bench - check all items for superficial or physical damage.

## Three Monthly

Clean all items as detailed below; check all fixings are seated correctly.

## Six Monthly

Secure all fixings; full clean as detailed below; check that bench is firmly secured to the ground

# Specific Maintenance Details

## Stainless Steel *(polished stainless steel only)*

Clean as required, but at least every three months, using a stainless steel polish and a lint free cloth. To remove ground in dirt, a stainless steel finishing pad may be required.

## Polyester Powder Coated & Galvanised

For general cleaning using a damp cloth and warm soapy water only. Scourers and abrasive cleaners are NOT suitable for these types of finish and may damage them. Before using cleaning agents to remove graffiti etc. try on a small inconspicuous area first to avoid causing more unsightly damage.

---

# Repairs

## **Stainless Steel**

Light damage (surface scratches etc.) can be removed using an emery pad (240 grit) and freeing oil such as 'WD40'. Care should be taken to follow the direction of the brushing grain. It is recommended that a trial repair be carried out on an unimportant surface first. No corrosive cleaners or other abrasives should be used. Any contamination, particularly carbon steel scuffs from vehicles, should be quickly removed to avoid corrosion.

## **Galvanised Surfaces**

For light damage to hot dipped galvanised finishes repair using a high performance cold galvanising zinc spray (70% zinc or above). Spray application should be carried out in accordance with approved methods detailed by the product manufacturer. Please note that it is advisable to use professional painters to achieve best results when touching up larger areas.

## **Polyester Powder Coated Surfaces**

For light damage (scratches, chips etc.) repair using touch-up paint to match original colour (available from Factory Furniture Ltd). Paint application should be carried out in accordance with approved methods detailed by the paint manufacturer. Please note that it is advisable to use professional painters to achieve best results when touching up larger areas. Products for respraying larger areas are available from Factory Furniture Ltd.

## **Heavy Damage**

In the event of serious damage to any component, replacements should be ordered from Factory Furniture Ltd. In this event (or if the product needs to be disassembled for any reason), please contact Factory Furniture for detailed technical advice.

# Reordering / Spares

There are no spare parts for this model of bench

# AutoCAD Drawing List

FF1001 / 01	BLOC BENCH (STEEL)	SEAT FABRICATION DRAWING
FF1001 / 02	BLOC BENCH (STEEL)	PARTS DETAILS DRAWING
FF1001 / 03	BLOC BENCH (STEEL)	SETTING OUT DRAWING

# Contacts

Factory Furniture Ltd  
The Stableyard,  
Coleshill,  
Swindon.  
Wiltshire SN6 7PT  
U.K.

Tel +44 (0) 1793 763829  
Fax +44 (0) 1793 861615  
Email [sales@factoryfurniture.co.uk](mailto:sales@factoryfurniture.co.uk)  
Web [www.factoryfurniture.co.uk](http://www.factoryfurniture.co.uk)

# Installation Instructions

**ALL INSTALLATION WORKS TO BE CARRIED OUT BY COMPETENT PERSONNEL - INSTALL AS COMPLETE UNIT.**

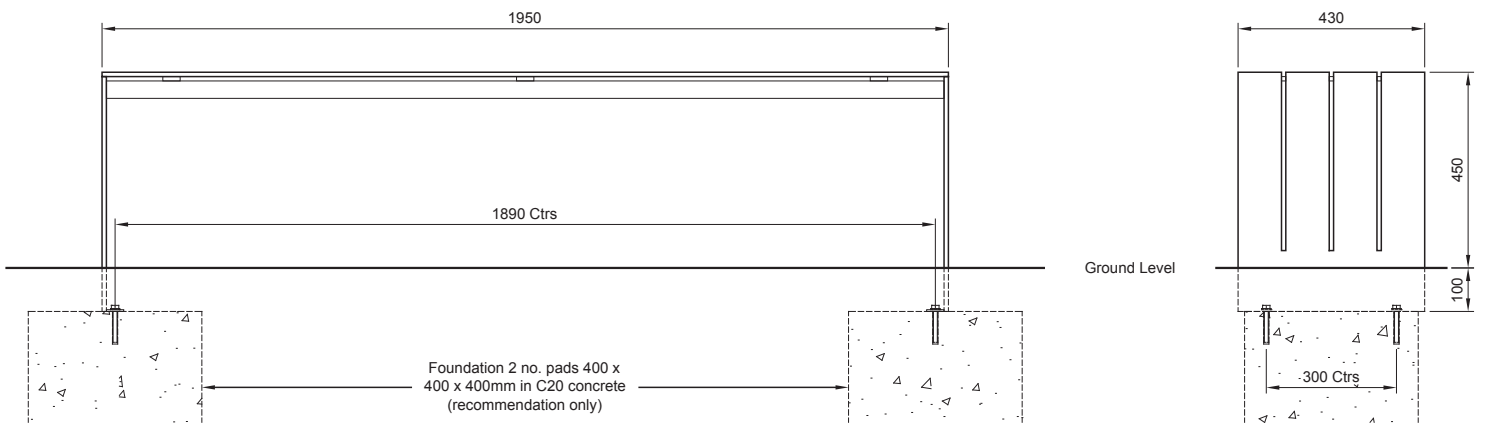
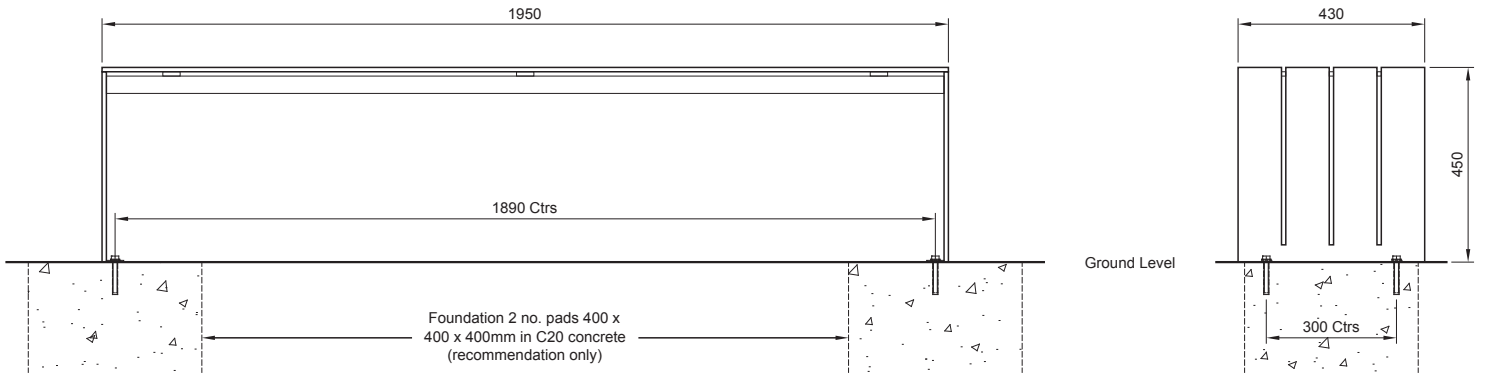

## **Bloc Bench (Steel)** (surface & sub-surface fix)

1. Install suitable foundation pads (see illustration) each with top face at ground level or 100mm below finished ground level for sub-surface fix
2. Position bench in correct orientation, with base centrally on foundation pads, then mark hole positions through fixing lugs.
3. Remove the bench; drill holes  $\text{Ø}12\text{mm}$  x 75mm deep (or as bolt manufacturer's recommendations).
4. Clear debris from holes.
5. Reposition bench unit and fix to foundation pads using 4 no. zinc-coated M10 x 75mm sleeve anchors tightened to 50Nm (or as per manufacturer's instruction). Ensure bench remains level during fixing process. For surface fix, hammer an anti-vandal armour ring over each bolt head to prevent tampering.
6. Check level & re-instate ground level if necessary (sub-surface fix).

### **IMPORTANT NOTE:**

Ensure that stainless steel is protected during site cutting of stone – contamination from disc cutters will produce corrosion on stainless steel components.

