

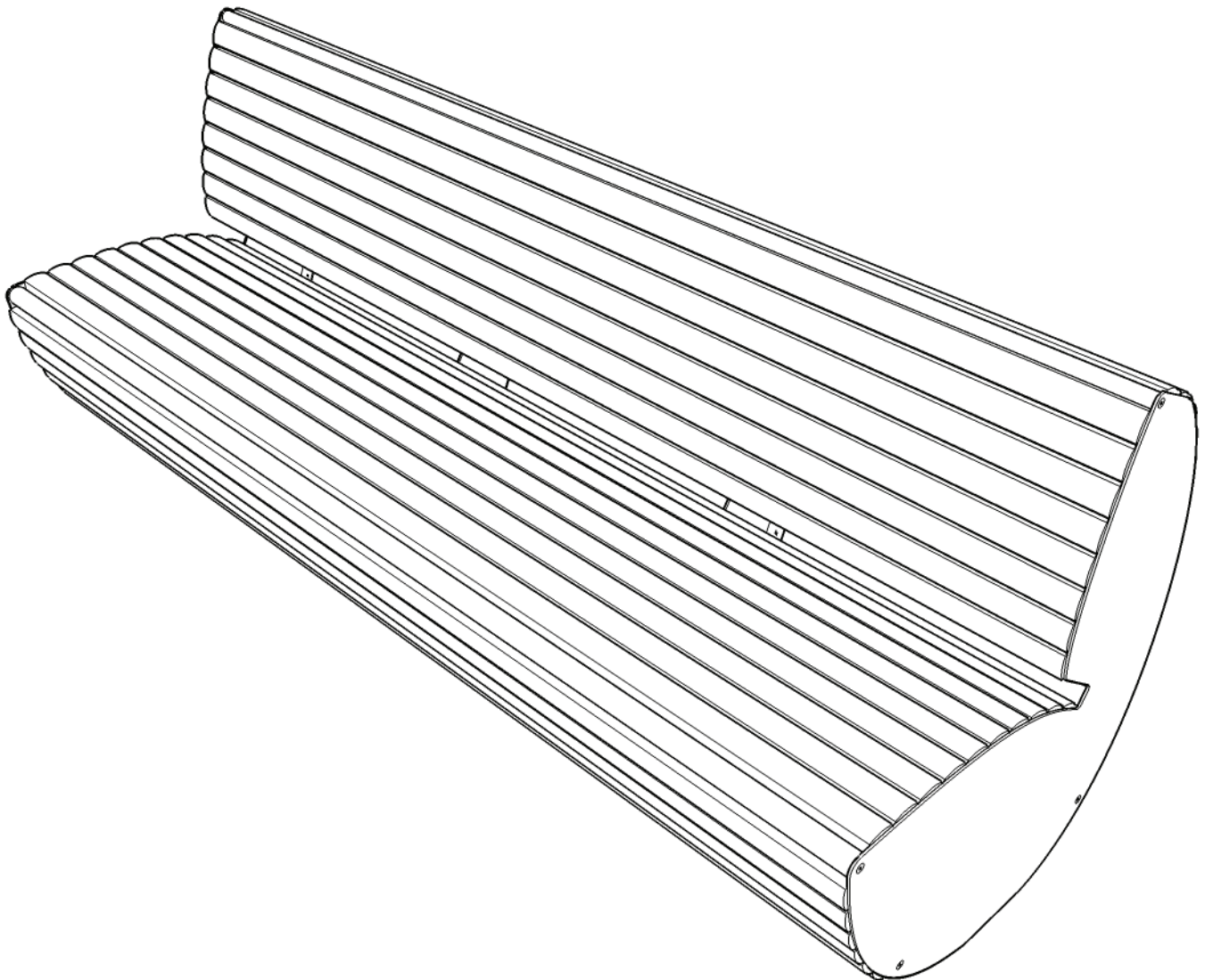

BOORT seat



Operation & Maintenance Manual

Introduction

Design

Design, shop drawings and development by Factory Furniture Ltd

Manufacture

Factory Furniture manufactured components. Products are assembled in Factory workshops, checked and dispatched ready for installation. Replacement products or components thereof should be ordered direct from Factory Furniture Ltd

Copyright

The design copyright for the product and drawing copyright remains the sole property of Factory Furniture Ltd

General Specifications

Seat

Metric length 2300mm | width 845mm | height 930mm

Imperial length 7' 6½" | width 2' 9½" | height 3' ½"

Approx Weight 239kg

Overall Fixing Centres 2200mm (7' 2½") x 100mm (4")

Detailed Material & Finish Specifications

Seat Slats

- Manufactured from FSC certified tropical hardwood
- Profiled and left untreated as standard (*oil or microporous woodstain treatment available on request*)
- Supported on frame attached with 4 no. fixing points each

Frame

- Manufactured from stainless steel - satin polished or polyester powder coated finish (*powder coat colour grey as standard or to customer specification*)
- Anchored (surface fix) using 2 no. resin fixed M10 x 200mm threaded rods and cap nuts per frame plate (8 no. fixings in total)

General Maintenance *(Recommended Schedule & Guidelines)*

Daily/Weekly/Monthly *(or as adopted)*

Visual checks of seat top and frame - check all items for superficial or physical damage.

Three Monthly

Clean all items as detailed below check all fixings are seated correctly; inspect timber for serious damage and splinters.

Six Monthly

Secure all fixings; full clean as detailed below; check that seat is firmly secured to the ground

Specific Maintenance Details

FSC Timber / Non-FSC Timber

Clean with a stiff brush once per year, especially in more exposed locations, in order to prevent a verdigris type build up on the timber surface. Ideally this should be completed in early spring. During the cleaning stage, all exposed timber surfaces should be inspected for splits and splinters. Any splinters and graffiti should be removed and the surface sanded with 100 grit sandpaper in order to remove any uneven / sharp edges or surfaces.

During the first few months after installation the tannin naturally occurring in the timber may leach out and cause a brown staining on the bases. This may be removed with a light solution of household bleach and water.

Stainless Steel *(polished stainless steel only)*

Clean as required, but at least every three months, using a stainless steel polish and a lint free cloth. To remove ground in dirt, a stainless steel finishing pad may be required.

Polyester Powder Coated

For general cleaning using a damp cloth and warm soapy water only. Scourers and abrasive cleaners are NOT suitable for these types of finish and may damage them. Before using any cleaning agents to remove graffiti etc. try on a small, inconspicuous area first to avoid causing more unsightly damage.

Repairs

FSC Timber / Non-FSC Timber

For light damage, please see section on specific maintenance details above. For instances of heavy damage, the timber item should be replaced. Please order against the part number reference in the reordering section towards the end of this manual.

Stainless Steel

Light damage (surface scratches etc.) can be removed using an emery pad (240 grit) and freeing oil such as 'WD40'. Care should be taken to follow the direction of the brushing grain. It is recommended that a trial repair be carried out on an unimportant surface first. No corrosive cleaners or other abrasives should be used. Any contamination, particularly carbon steel scuffs from vehicles, should be quickly removed to avoid corrosion.

Polyester Powder Coated Surfaces

For light damage (scratches, chips etc.) repair using touch-up paint to match original colour (available from Factory Furniture Ltd). Paint application should be carried out in accordance with approved methods detailed by the paint manufacturer. Please note that it is advisable to use professional painters to achieve best results when touching up larger areas. Products for respraying larger areas are available from Factory Furniture Ltd.

Heavy Damage

In the event of serious damage to any component, replacements should be ordered from Factory Furniture Ltd. In this event (or if the product needs to be disassembled for any reason), please contact Factory Furniture for detailed technical advice.

Reordering / Spares

Part No.	Item Description
P1025 / 01	1 no. Boort slat set (40 slats in total - does not include frame)
P1025 / 02	1 no. Boort outer frame plate
P1025 / 03	1 no. Boort Ø38mm frame tube
P1025 / 04	1 no. Boort Ø25mm frame tube

Instructions For Reordering

If possible, please specify job name or number at the time of reordering to enable identification of details such as the original species of timber used, stainless steel finishes and polyester powder coat colours etc. In any event where either, additional orders are required, or spares and replacements are required please contact Factory Furniture Ltd. Using the part numbers given above as reference should help us to process your enquiry more efficiently.

Note - All fittings required to assemble ordered parts will automatically be included in the order.

AutoCAD Drawing List

FF1025 / 01	BOORT SEAT	FABRICATION DRAWING
FF1025 / 02	BOORT SEAT	PARTS DETAIL DRAWING
FF1025 / 03	BOORT SEAT	SETTING OUT DRAWING

Contacts

Factory Furniture Ltd,
The Stableyard,
Coleshill,
Swindon.
Wiltshire SN6 7PT
U.K.

Tel +44 (0) 1793 763829
Fax +44 (0) 1793 861615
Email sales@factoryfurniture.co.uk
Web www.factoryfurniture.co.uk

Installation Instructions

ALL INSTALLATION WORKS TO BE CARRIED OUT BY COMPETENT PERSONNEL - INSTALL AS COMPLETE UNIT.

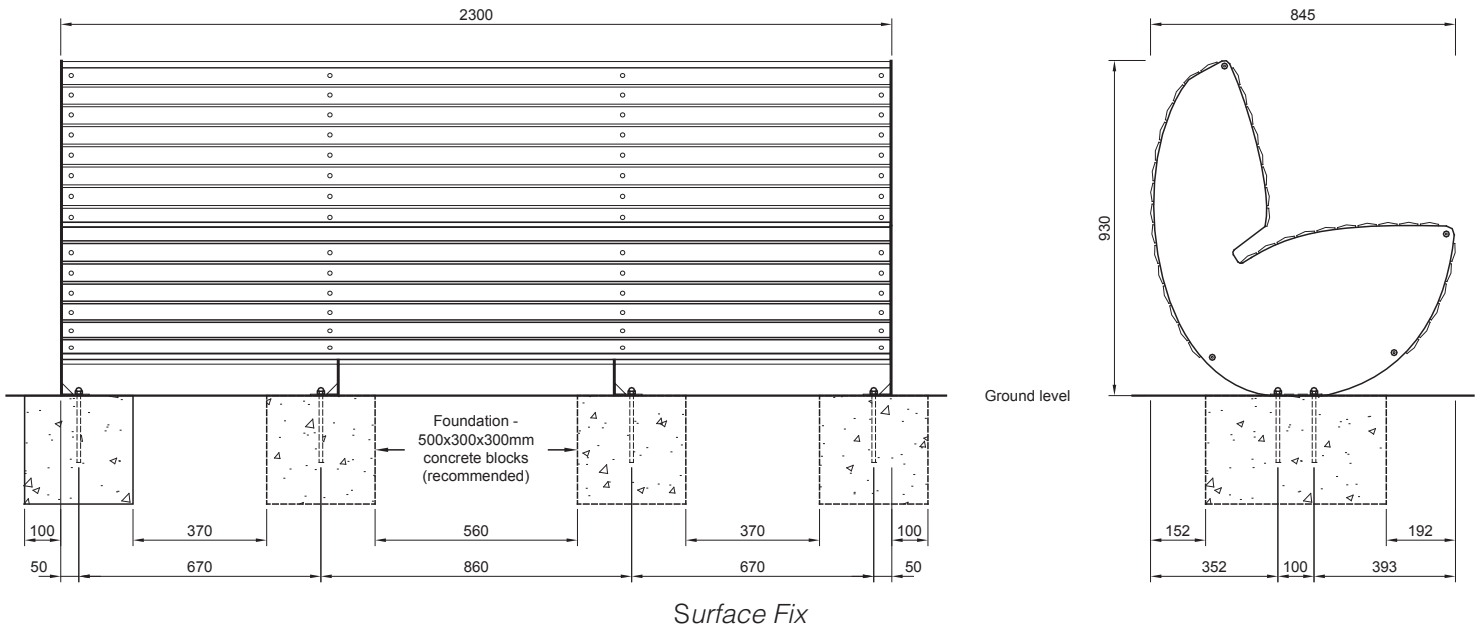

Boort Seat (surface fix only)

1. Install suitable foundation pads (see illustration) each with top face at ground level
2. Position seat in correct orientation with bases centrally on foundation pads, then mark hole positions through base plates.
3. Remove the seat; drill holes $\text{\O}12\text{mm}$ x 200mm deep
4. Clear debris from holes.
5. Fill the holes to within approximately 35mm from the top with Hilti HY150 resin (or similar). Lift the seat (with threaded anchor rods/capnuts in place) and carefully lower the anchors into the holes, leave for two hours before using.
6. Using a torque wrench, tighten nuts and washers over flange plates to 30Nm to fasten down the seat. Ensure seat remains level during fixing process.

IMPORTANT NOTE:

Ensure that stainless steel is protected during site cutting of stone – contamination from disc cutters will produce corrosion on stainless steel components.

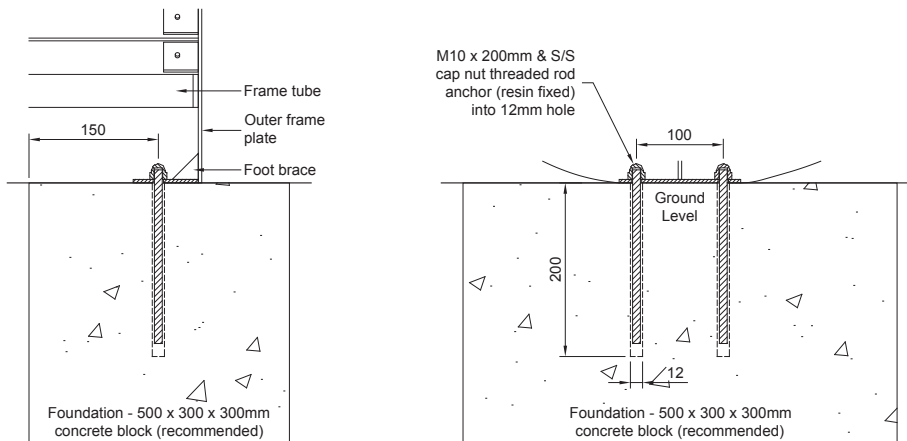

Leg Fixing Details