

# Automatic Door Equipment

## Supplied, Supported, Independent

We supply automatic equipment and support to independent companies working in the field of door automation.

Our forte is supplying our heavy duty operating equipment at realistic prices.

Our equipment is simple to fit, heavy duty with an affordable price. With Its high specification and flexible uses it is fast becoming an industry leader within automation.

SLIDING OPERATORS // SWING OPERATORS  
FOLDING DOORS // RETROFIT KITS

### Key Benefits / Features

- + Full technical support
- + FREE TRAINING COURSES
- + Low cost maintenance
- + Architectural wording and specifications available
- + CAD drawings
- + Next day delivery
- + Comprehensive guarantee
- + Economical and reliable
- + Fully compliant with BS7036 : 1996
- + Intelligent control units with simple setup
- + Designed by engineers with over 30 years experience in automatic pedestrian doors

GLOBAL  
AUTOMATICS LTD



The First Independent, Customer  
Branded Sliding Door Operator

## Premier-Slide 100

[www.global-automatics.com](http://www.global-automatics.com)

+ The only Independent Sliding Door Operator on the market. – Completely unbranded

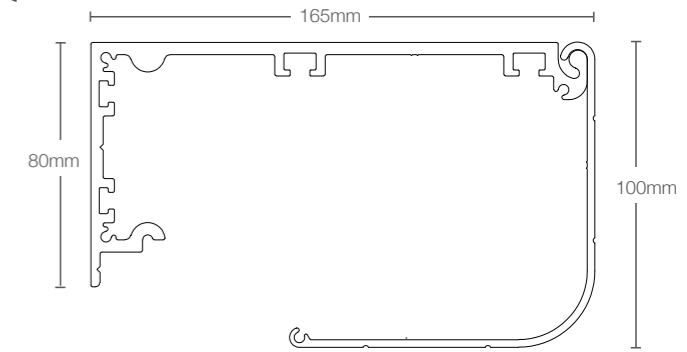

### Key Features

- + Only 10cm High – allowing this to be one of the most versatile operators on the market
- + Highly reliable – 18 months warranty \*
- + Designed for easy installations, repairs and servicing
- + Highly precise microprocessor driven control unit with optimum adjustments
- + Original Heavy duty Dunker Motor / gearbox – 100w
- + Interlock function for Secured Access Doors
- + Self setup system and monitored battery backup – in accordance with Bs7036:1996
- + Canopy stay – to hold up the canopy for easy installation and maintenance
- + Designed and manufactured in the UK

### Safety Functions

- + Monitored sensors for the safest possible automatic door
- + Intelligent emergency escape system – programmable to open, close or continue in normal operation upon power failure
- + Emergency stop function
- + Dedicated removable plugs for connecting all types of automatic door sensors

### Motor Gearbox

- + Heavy Duty “Dunker Motor” 100w with Built in Electric Brake



Heavy Duty Motor Gearbox

### Control Unit

- + An intelligent control unit with variable adjustments on all functions to allow easy integration
- + Dedicated connections for each sensor
- + “Plug and Play” sensors available

### Customer Operating Modes

- + Automatic
- + Exit Only or Enter Only
- + Hold Open
- + Partial Opening (same functions as automatic but with an adjustable reduced opening)
- + Auto Width – Self adjusting opening, dependant on the frequency of pedestrian traffic
- + Pharmacy
- + Closed

### Access Panel

- + Acts as a switch for customers to change the doors function
- + Allows easy adjustments and setup via the “engineers mode”
- + Fault diagnostics with faults displayed on screen
- + Uploaded with your logo and telephone number
- + Screen saver and auto lock functions to prevent unauthorised usage

### Drive System and Track

Heavy duty steel brackets, reinforced toothed belt and a high quality extruded housing make this operator suitable for heavy and high usage door sets. Our use of nylon wheels on an aluminium track make for the quietest possible operation. Canopies are available in SAA or Mill for powder coating

\* The Motor gearbox and Control unit have an 18 month warranty. All other components such as batteries, and mechanical items have a 12 month warranty.