

HORNE®

THERMOSTATIC CONTROL TECHNOLOGY



HORNE SWM1
THERMOSTATIC STEAM AND WATER MIXING VALVE

APPLICATIONS

MIXING STEAM AND COLD WATER TO PROVIDE HOT WATER, AT A CONTROLLED TEMPERATURE, FOR:

- > plant washdown facilities.
- > vat or tank filling.
- > industrial washing machines.



Fig.1

FEATURES

HOT WATER IMMEDIATELY AVAILABLE.

HOT WATER TEMPERATURE CONTROLLED BY A THERMOSTAT.

COLD WATER FLOW REQUIRED TO OPEN STEAM VALVE.

EASE OF USE.

EASE OF MAINTENANCE.

RELIABILITY AND DURABILITY.

BENEFITS

NO NEED TO STORE HOT WATER IN CALORIFIERS OR TANKS.

HOT WATER, AT THE REQUIRED TEMPERATURE, AVAILABLE IRRESPECTIVE OF CHANGES IN INLET STEAM AND COLD WATER SUPPLY PRESSURES.

STEAM CAN NOT ENTER THE SWM1 VALVE UNTIL COLD WATER IS PASSING THROUGH IT. IF THE COLD WATER SUPPLY PRESSURE DROPS SIGNIFICANTLY OR THE SUPPLY FAILS OR IS TURNED OFF, THE STEAM SUPPLY IS AUTOMATICALLY CUT OFF.

NO NEED TO ADJUST BY-PASS VALVES, CHANGE SPRINGS OR OTHER VALVE INTERNALS ON SITE TO COPE WITH CHANGES IN STEAM AND/OR COLD WATER SUPPLY PRESSURES.

EASILY STRIPPED AND CLEANED WITH THE MINIMUM OF DOWNTIME.

MATERIALS OF CONSTRUCTION SPECIFICALLY CHOSEN TO GIVE A TROUBLE FREE WORKING LIFE.

OPERATING CONDITIONS

Max. steam pressure	10 bar g	Min. steam pressure	0.7 bar g
Max. cold water pressure:	10 bar g	Min. cold water pressure:	0.25 bar g
Max. hot water flow rate:	50 l/min	Min. hot water flow rate:	10 l/min

RANGE OF TEMPERATURE ADJUSTMENT

The temperature control on the SWM1 valve can be adjusted and set at any temperature within the range 50°C to 85°C.

DIMENSIONS

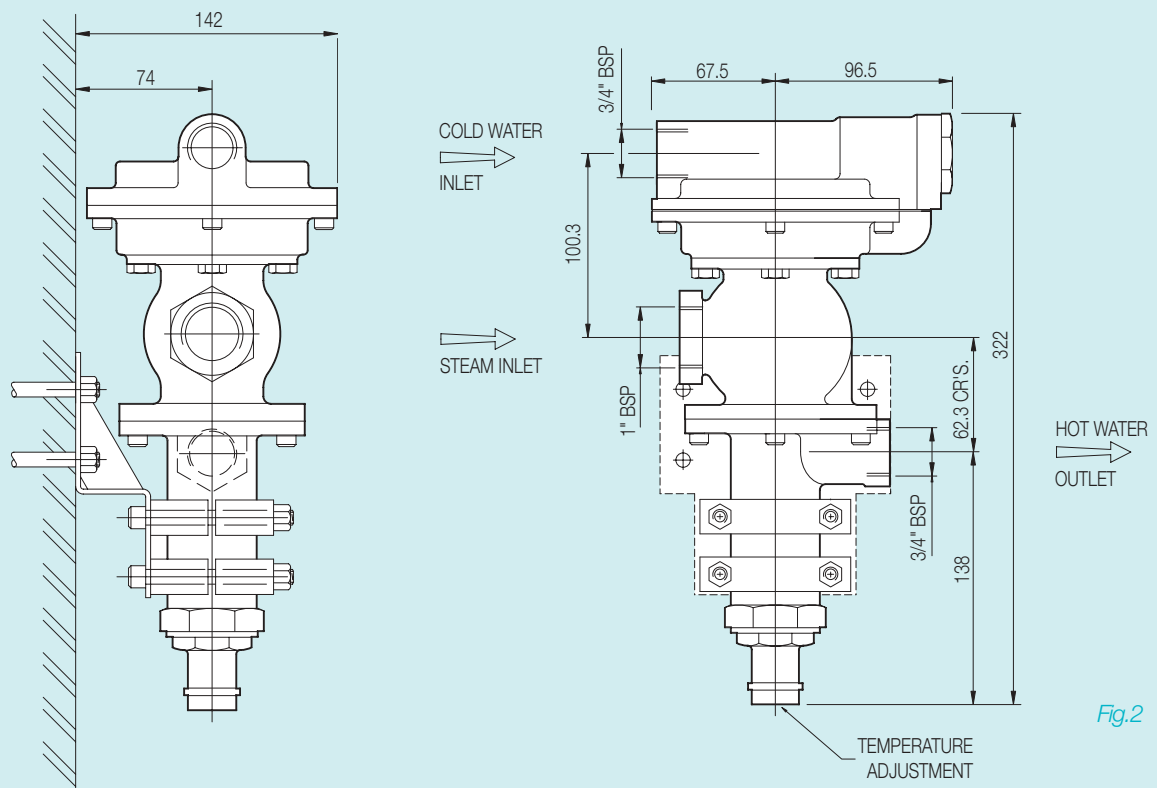

Fig.2

HORNE SWM1 STEAM AND WATER MIXING VALVE WITH WALL MOUNTING BRACKET

PIPE CONNECTIONS

Steam inlet connection; 1" BSP.

Cold water inlet connection; 3/4" BSP.

Hot water outlet connection; 3/4" BSP.

MATERIALS OF CONSTRUCTION

The materials of construction have been specifically chosen to ensure reliability and durability.

Cast components;	LG2 gunmetal.
Surface finish;	Electroless nickel plated.
Steam valve seat;	PEEK.
Steam valve disk;	Stainless steel grade 303.
By-pass valve disk;	Acetal.
Rolling diaphragm seal;	Polyester fabric reinforced EPDM
Seals;	Viton "O" rings.
Springs;	Stainless steel to BS2056 Type 302 S26.

The Thermostat Element is a wax filled capsule, which provides accurate temperature control.

The piston is sealed by a rolling diaphragm.

Both these components provide a long and trouble free working life.



Fig.3

HOW THE SWM1 VALVE WORKS

The flow of steam is controlled by the *steam valve* which is held closed by steam pressure and cannot open until there is a downward thrust from the *piston*. The required thrust is generated by the pressure drop across the *piston*, when cold water passes through the *flow passage* in the *piston*. A *rolling diaphragm* provides a frictionless seal at the *piston*.

Before steam can enter the SWM1 valve, there must be a flow of cold water through it.

This means that if the cold water supply pressure falls significantly or the supply fails or is turned off; the steam supply will automatically be stopped.

As soon as the hot water outlet is opened cold water starts flowing through the SWM1 valve via the *flow passage* in the *piston*. There is, therefore, a pressure drop across the *piston* and the resulting thrust moves the *piston* downwards and opens the *steam valve*.

Steam starts flowing and mixes with the cold water to make hot water.

To ensure minimal vibration and quiet operation, of the SWM1 valve, the cold water is injected into the steam through a series of *small holes*.

The hot water stream passes over the *thermostat element* and the expansion or contraction of the element moves the *steam valve*. This regulates the flow of steam, mixing with the cold water, and the hot water temperature is controlled.

The hot water temperature can easily be adjusted and set by turning the *temperature adjusting screw* with a removable temperature adjusting key.

The range of temperature adjustment is 50 - 85°C.

The *by-pass valve* opens to allow an increased flow of cold water when there is a large demand for hot water. The amount by which the *by-pass valve* opens is controlled by the *by-pass spring*.

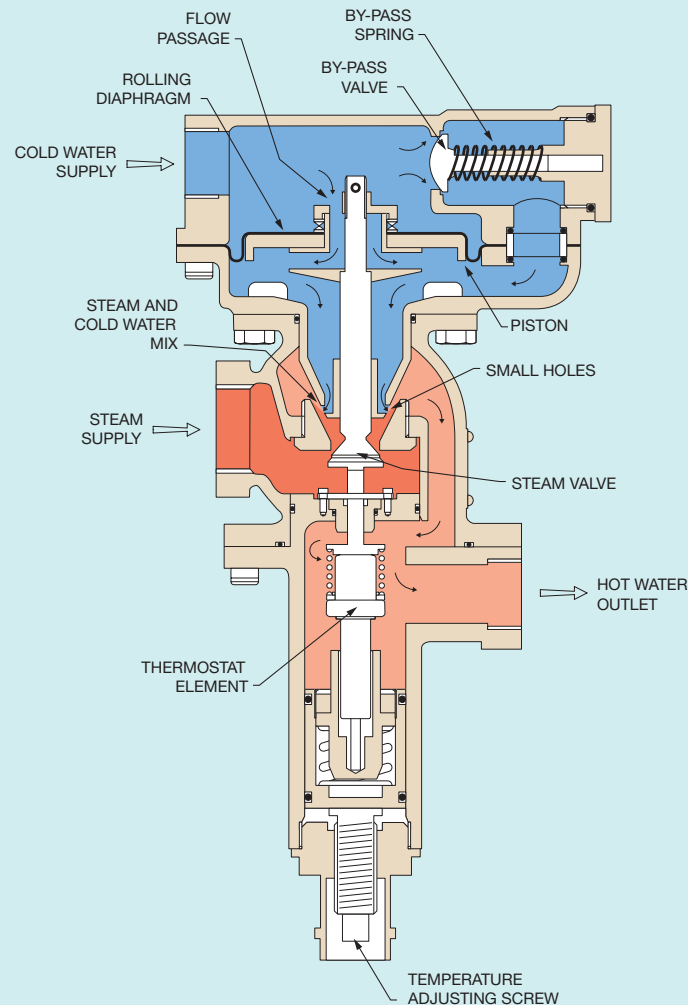
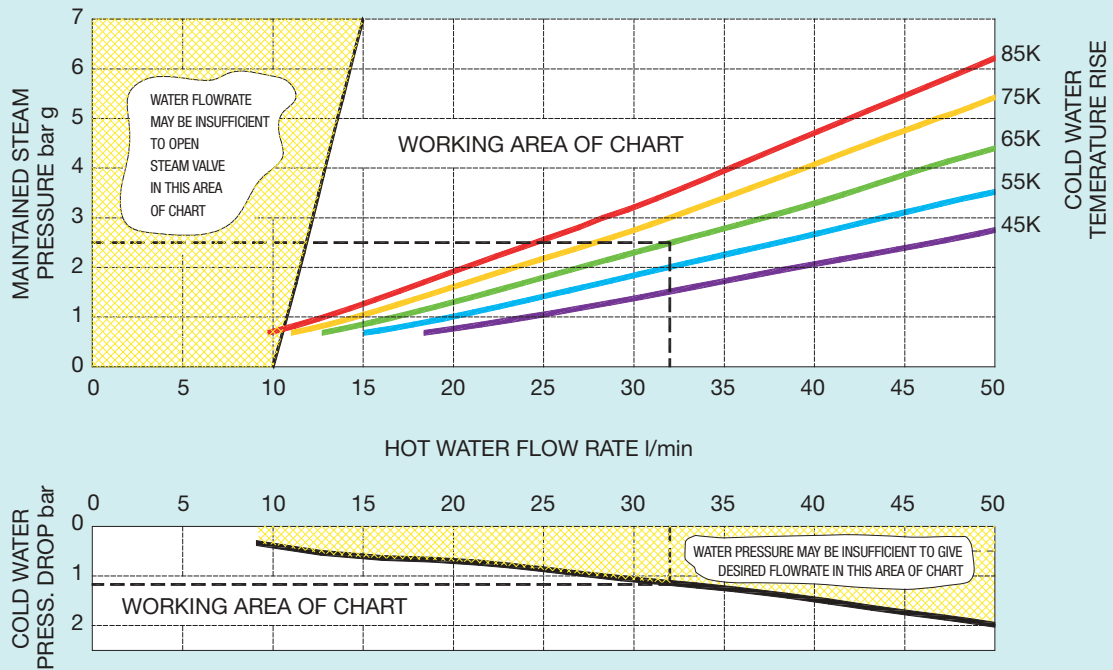

Fig.4

CAPACITY CHART



NOTE: THE "MAINTAINED" STEAM PRESSURE REFERS TO PRESSURE WITH THE SUPPLIES RUNNING

Fig.5

The Upper Chart shows Steam Pressure against Hot Water Flow Rate and the Lower Chart shows Cold Water Pressure Drop against Hot Water Flow Rate. The hot water flow rate has been measured when discharging to an open outlet.

WORKED EXAMPLE 1

If 32 l/min of hot water is required at a temperature of 75°C and the cold water supply temperature is 10°C to find the minimum maintained steam pressure required and the cold water pressure drop across the valve proceed as follows.

The temperature rise from 10°C to 75°C is 65°K.

Draw a line on the upper chart vertically upwards from 32 l/min on the **hot water flow rate** scale until it intercepts with the 65°K **cold water temperature rise** curve.

From the point of interception draw a line horizontally to the left until it intercepts with the **maintained steam pressure** scale and read off the pressure.

It will be seen, in this example, that the minimum maintained steam pressure required is 2.5 bar g.

Steam pressures higher than 2.5 bar g are acceptable. The HORNE SWM1 valve is thermostatic and, therefore, once the temperature setting has been adjusted to control the hot water temperature at 75°C, the SWM1 Valve will throttle a higher steam pressure to maintain the desired temperature of 75°C.

To find the minimum cold water pressure drop across the valve draw a line on the lower chart vertically downwards

from 32 l/min. on the **hot water flow rate** scale until it intercepts with the **cold water pressure drop** curve.

At the point of intersection draw a line horizontally to the left until it intercepts with the **cold water pressure drop** scale.

It will be seen that the minimum cold water pressure drop across the valve is 1.2 bar.

If the cold water supply pressure is higher than necessary to generate a pressure drop across the valve of 1.2 bar the flow rate of hot water will be more than 32 l/min. and, depending on the steam pressure, there may be a drop in hot water temperature.

When the hot water flow rate is higher than the required rate the COMMISSIONING VALVE (see page 7) should be closed slightly to throttle the cold water flow rate until the required hot water flow rate of 32 l/min. is achieved.

Please note that the cold water pressure drop referred to above is across the HORNE SWM1 valve only. There will obviously be other fittings causing pressure drops and pipework losses to be taken into account when estimating the pressure drop across the complete system.

WORKED EXAMPLE 2

If the required hot water temperature is 75°C, the cold water temperature is 10°C and the steam pressure is 2.5 bar g, to find the flow rate of hot water at 75°C proceed as follows.

The temperature rise from 10°C to 75°C is 65°K, therefore, from the 2.5 bar g point on the ***maintained steam pressure*** scale draw a line horizontally to the right until it intercepts with the 65°K ***cold water temperature rise*** curve. From this point draw a line vertically downwards until it intercepts with the ***hot water flow rate*** scale and read off the flow rate.

It will be seen, in this example, that the flow rate is 32 l/min.

Now check the cold water pressure drop across the SWM1 valve as follows.

On the lower chart draw a line vertically downwards from the 32 l/min point until it intercepts with the ***cold water pressure drop*** curve.

From this point draw a line horizontally to the left until it intercepts with the ***cold water pressure drop*** scale.

Read off the cold water pressure drop and in this example it will be seen that the cold water pressure drop across the SWM1 valve is 1.2 bar.

It will be necessary to check the pressure of the cold water supply to ascertain if a pressure drop of 1.2 bar is acceptable or not.

If the cold water supply pressure is so high that the pressure drop is more than 1.2 bar it will be necessary to throttle the COMMISSIONING VALVE until the hot water flow rate is 32 l/min.

INSTALLATION ARRANGEMENT

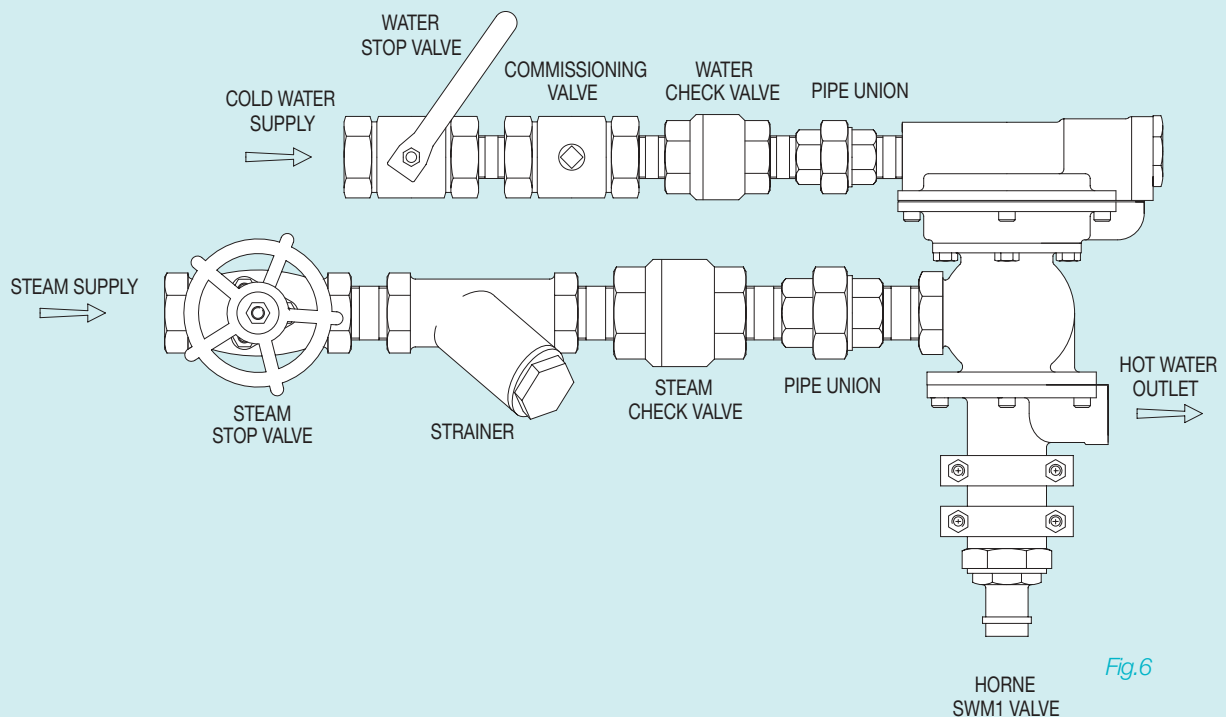

INSTALLATION ARRANGEMENT SHOWING THE NECESSARY COMMISSIONING VALVE, CHECK VALVES, STRAINER, ISOLATING VALVES AND PIPE UNIONS PRE-ASSEMBLED READY FOR INSTALLATION OF THE SWM1 VALVE ON SITE.

HORNE

HORNE ENGINEERING Ltd
PO Box 7, Rankine Street
Johnstone, United Kingdom PA5 8BD
tel +44 (0) 1505 321455
fax +44 (0) 1505 336287
email sales@horne.co.uk
web www.horne.co.uk