

Mono[®]

A National Oilwell[®] Company

THE LF RANGE

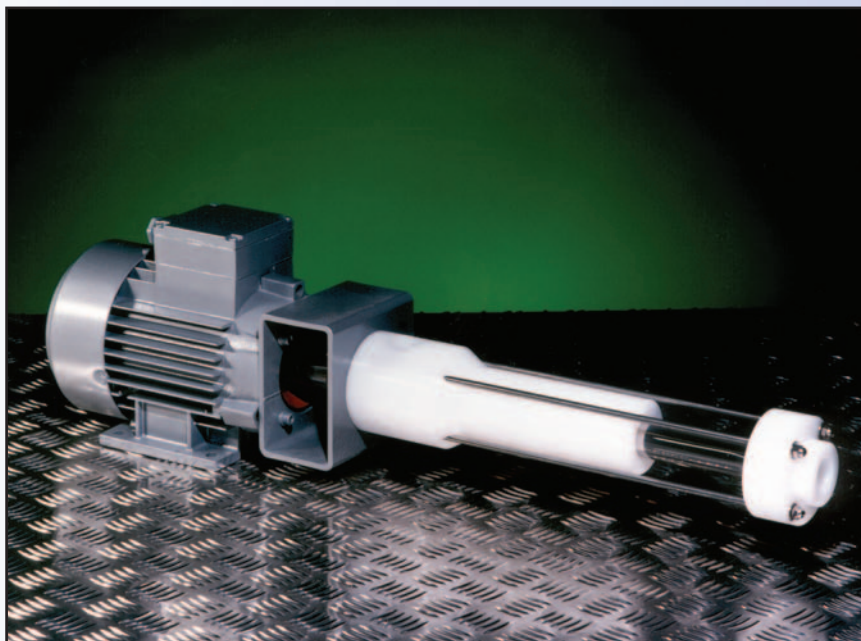

Mono[®]

Low Flow Pumps for Dosing

Accuracy, Reliability, Simplicity

The Mono Pedigree

Mono have been at the forefront of progressing cavity pump design since 1935. With the experience gained from over 65 years we are able to reflect the varying needs of our extensive customer base worldwide. And an all round efficiency and quality which our customers demand, and to which we are committed.

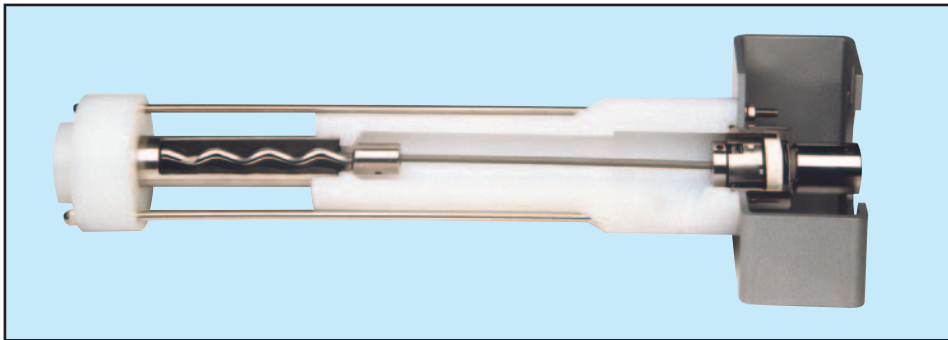

The LF Range

Designed for use where accurate, low flow pumps are required for either intermittent or continuous dosing, the compact LF pumps have high tolerance to aggressive chemicals and the renowned reliability of Mono.

The LF pumps have a repeatability of $\pm 2\%$ and operating temperatures from 0 to 70°C for the standard configuration.

Specification

Four two stage models are available covering 0 to 600 l/hr, up to 12 bar. The standard housing is polyethylene, with the option of stainless steel.

All four models use one suction housing, end cover and drive mount. Assembly and dismantling is facilitated through use of tie bars and all utilise the Flexishaft® drive train.

Stators can be supplied in natural rubber, nitrile and viton and rotors are available in stainless steel or stainless steel hard chrome plate.

Single mechanical seal is standard and there are four drive configurations - AC synchronous, fixed speed gear box, DC and variable speed gear box.



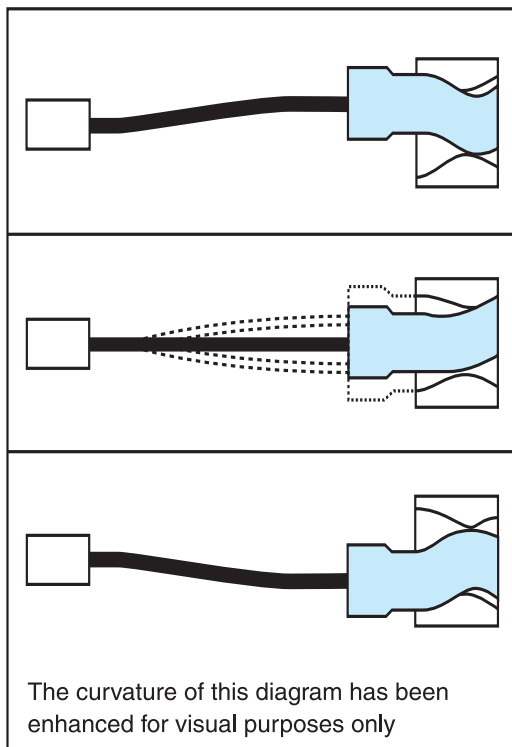

**The Flexishaft is supported by
a 5 year warranty**

Mono Features

The pump is self priming, and the gentle non pulsating pumping action helps maintain product integrity with even the most difficult materials. The range of suitable substances includes viscous and slurry products, solids in suspension and air/liquid/solids mixtures.

These versatile pumps have output directly proportional to speed.

The Flexishaft®

The Flexishaft links the drive shaft to the helical rotor. Conceived by Mono Pumps in the early 1970's, it is a unique solution to the problem of connecting the pump drive shaft to the eccentrically orbiting rotor; completely eliminating conventional universal joint designs.

The Flexishaft is manufactured from a toughened stainless steel material using a specific process for Mono and is covered with an abrasion and corrosion-resistant food approved coating.

The benefits of the Flexishaft are particularly apparent in process industries, where both continuous and batch production demand reliable equipment.

Flexishaft Design Parameters

In designing the Flexishaft the considerations and design criteria are similar to those of other components requiring high reliability which are subject to a high number of cycles of alternating stress. Examples would include gear teeth, lift winding gear, springs and aircraft structures.

In operation, the Flexishaft is subjected to a combination of steady state and alternating stresses. The latter results from the flexing of the shaft and during one revolution the Flexishaft is subjected to two cycles of alternating stress. The Flexishaft proportions are designed to ensure that this stress is well below the elastic limits of the material, to ensure no deformation of the Flexishaft.

Flexishaft Features and Benefits

Because there are no moving and, therefore, no wearing parts, the LF range does not incur the cost of maintenance associated with other forms of rotor/coupling joints.

Lubrication is unnecessary and therefore product contamination is eliminated providing the pump is operated within the specified operating conditions - even in the unlikely event of joint failure.

Performance Date

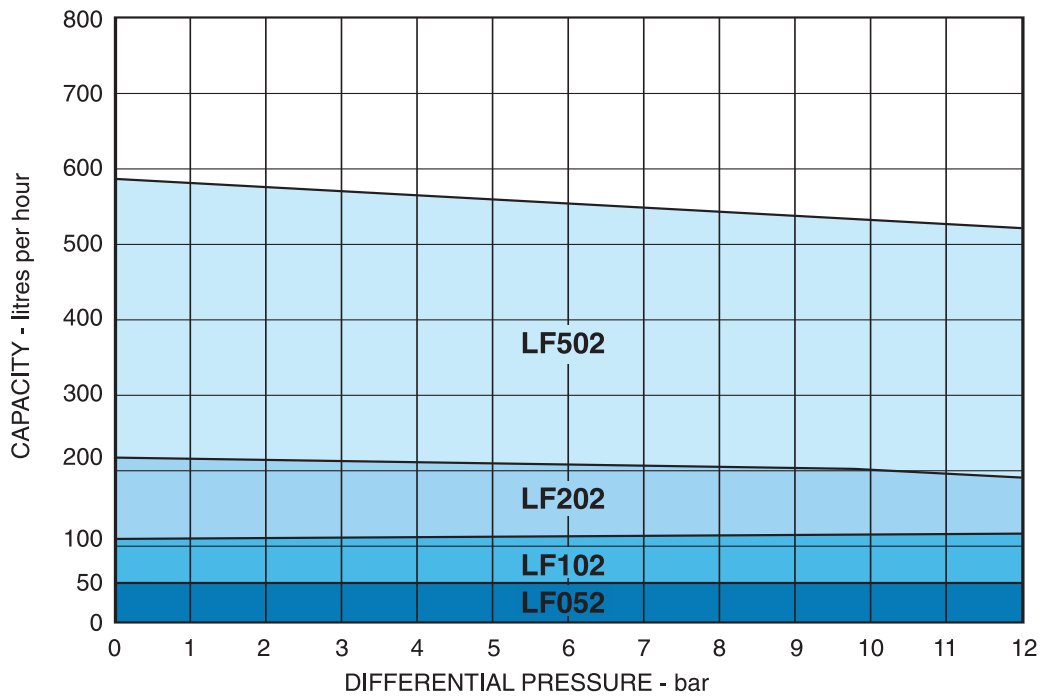

PUMP		PRESSURE - bar									
MODEL NUMBER	SPEED RPM	0		3		6		9		12	
		l/h	l/min	l/h	l/min	l/h	l/min	l/h	l/min	l/h	l/min
LF052	1750	65	1.08	63	1.05	61	1.02	59	0.98	58	0.97
	1450	52	0.87	51	0.85	50	0.83	48	0.80	47	0.78
	1000	36	0.60	35	0.58	34	0.57	32	0.54	31	0.52
	700	25	0.42	24	0.40	23	0.38	22	0.36	21	0.35
	400	14	0.23	13	0.22	12	0.20	11	0.18	10	0.17
LF102	1750	108	1.80	104	1.73	100	1.67	95	1.59	92	1.53
	1450	90	1.50	87	1.44	83	1.38	78	1.31	75	1.25
	1000	62	1.03	59	0.98	55	0.92	52	0.86	49	0.82
	700	44	0.73	41	0.68	37	0.62	34	0.56	31	0.52
	400	25	0.42	23	0.38	20	0.33	16	0.27	13	0.22
LF202	1750	215	3.58	209	3.48	202	3.37	196	3.26	192	3.20
	1450	180	3.00	174	2.89	167	2.78	160	2.67	156	2.60
	1000	122	2.03	117	1.95	112	1.87	105	1.75	100	1.67
	700	86	1.43	82	1.36	77	1.28	70	1.17	65	1.08
	400	50	0.83	45	0.75	40	0.67	35	0.58	30	0.50
LF502	1750	580	9.67	565	9.42	550	9.17	533	8.89	525	8.75
	1450	480	8.00	469	7.82	458	7.63	440	7.33	428	7.13
	1000	330	5.50	319	5.31	307	5.12	291	4.86	280	4.67
	700	230	3.83	219	3.65	208	3.47	194	3.23	182	3.03
	400	135	2.25	123	2.04	110	1.83	98	1.64	88	1.47

NOTES: Performance data are typical only on clean water at 20°C.
For guidance in selecting pumps for use with other fluids of varying abrasion and viscosity, refer to Mono Pumps or your agent.

LF Dosing Pump Range Coding

FEATURE	DESCRIPTION	BASIC PUMP CODING										STD. VARIATION					
		1	2	3	4	5	6	7	8	9	10	11	12	13	14	15	
BODY MATERIALS	UHMW POLYETHYLENE	P															
	STAINLESS STEEL	S															
PUMP DESIGN	LOW FLOW		L	F													
NOMINAL PUMP	60 Litres/h				0	5											
	100 Litres/h				1	0											
	200 Litres/h				2	0											
	500 Litres/h				5	0											
PUMP STAGES	TWO						2										
DRIVE ARRANGEMENT	DRIVE TYPE								1								
	(see table below)							2									
								3									
								4									
MARK NUMBER	1992								1								
STATOR MATERIAL	NATURAL										A						
	NITRILE										R						
	HIGH NITRILE										J						
	HYPALON										H						
	VITON										V						
	HYDROGENATED NITRILE										O						
	ETHYLENE PROPYLENE										E						
	WHITE NITRILE										W						
ROTATING PARTS (refer to Section 1, page 3)	316S16 Rotor											5					
	316S16 Rotor (HCP or Ceramic)											8					
	Hastelloy											9					
MARKET VARIATIONS	'G' - BSP Tapped												/	H			
	'C' - BSP Tapped - Australian Spec												/	C			
	'P' - American Spec. Gearbox & NPT Threads												/	E			
CODING	Mark 3 Rotor														4	2	1
	Mark 5 Rotor														4	2	3
EXAMPLE OF TYPICAL CODING		P	L	F	2	0	2	1	1	A	5	/	G				

	DRIVE DESCRIPTION	REMARKS
DRIVE TYPE 1	AC MOTOR - IEC80 - B14	FOOT AND FLANGE MOUNT - B14 <u>19mm</u> SHAFT DIAMETER
DRIVE TYPE 2	GEARED MOTOR AC or DC VARIABLE SPEED (BELT)	FOOT AND FLANGE - B14 <u>20mm</u> SHAFT DIAMETER
DRIVE TYPE 3	GEARED MOTOR AC or DC VARIABLE SPEED (BELT)	FOOT AND FLANGE MOUNT - B14 <u>19mm</u> SHAFT DIAMETER
DRIVE TYPE 4	NEMA 56C	FOOT AND FLANGE MOUNT - B14 <u>5/8"</u> SHAFT DIAMETER

FOR OPTIONS NOT DETAILED ABOVE, PLEASE REFER TO MONO PUMPS LTD., AUDENSHAW, MANCHESTER

LF Range Dimensions & Drive Variations

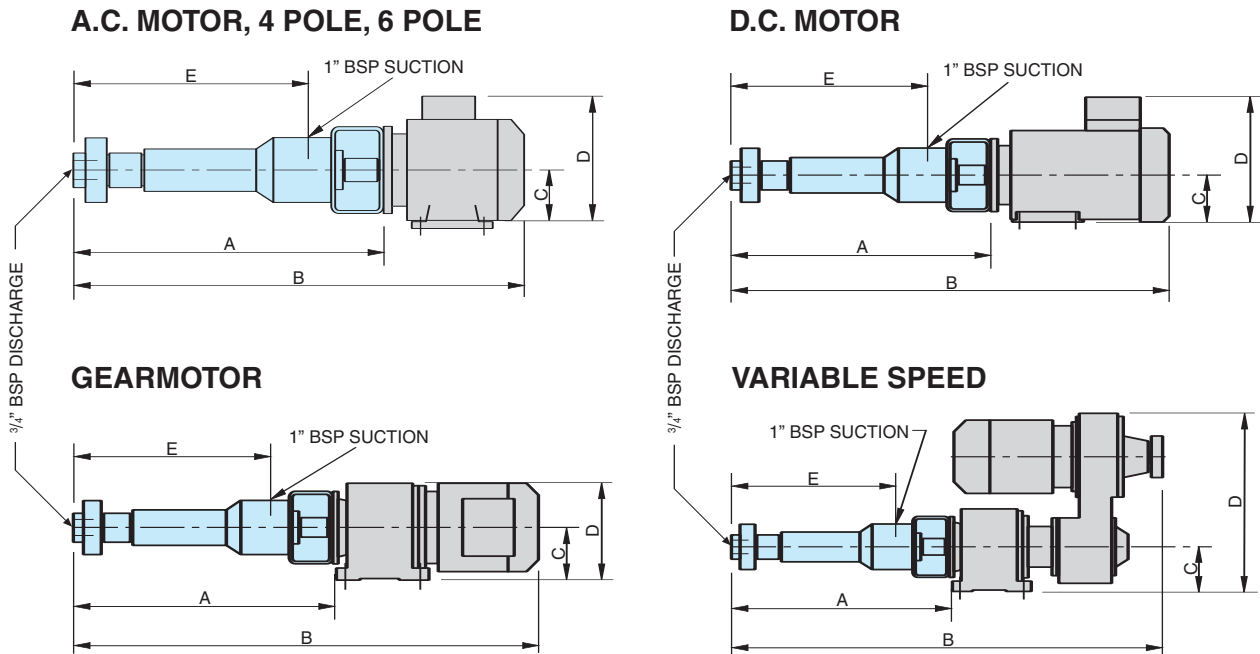

DRIVE VARIATION	PUMP MODEL	A	B	C	D	E
A.C. MOTOR	LF052/LF102	444	699	80	213	334
	LF202	466	721	80	213	356
	LF502	498	753	80	213	388
D.C. MOTOR	LF052/LF102	444	752	80	213	334
	LF202	466	774	80	213	356
	LF502	498	806	80	213	388
GEARMOTOR	LF052/LF102	444	846	90	164	334
	LF202	466	868	90	164	356
	LF502	498	900	90	164	388
VARIABLE SPEED	LF052/LF102	444	876	90	359	334
	LF202	466	898	90	359	356
	LF502	498	930	90	359	388

1. All dimensions are given for guidance only. For full certified drawings refer to Mono Pumps., Audenshaw, Manchester.

2. All dimensions in millimetres unless otherwise stated.

Applications and Support

The use of different stator materials enables the LF Range to be used for a wide range of products, including:

- Acids
- Alkalis
- Photographic
- Cosmetics
- Cyanide
- Waste Water Treatment
- Food ingredients
- Brewing, winemaking
- Chemical processing
- Process mining
- Dyes, inks
- Flocculants

2 LF pumps delivering sulphuric and sulphonic acid at a steady and consistent flow

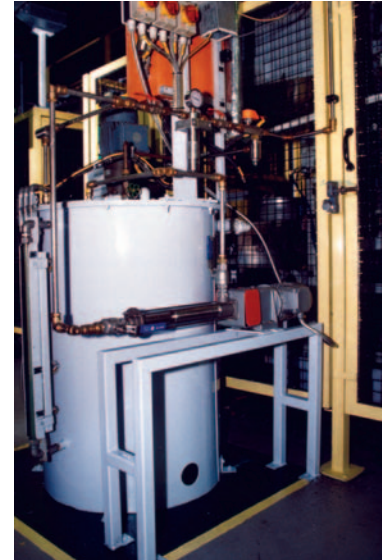

An LF pump installed to pump soap lubricant from a storage tank, through a filter to spray guns



Service and Technology

At Mono Pumps, our philosophy is to provide full product and technical support that meets with your exact requirements, including quality, availability and price.

The latest technology is used, such as computer based flexible manufacturing systems, computerised bar stores and information systems. We are unique in having three stator manufacturing operations worldwide to ensure that we produce pumps and parts to a consistently high standard in the local area, readily available.

Attention to detail, combined with a wealth of technical advice and CAPS (Computer Aided Pump Selection) ensures you will receive a product that is quality assured. Mono is approved to ISO 9001:2000 and manufactures products within a Quality Management System which is independently measured against industry recognised standards throughout the world.

With over 700 authorised outlets located throughout the world to provide the local support you need, the Mono Pumps Group can offer you the following services:

- Pre sales assistance
 - Quotations for applications
 - Pump availability
 - Spares availability
 - Trouble shooting
 - Warranty and after sales service
 - Installation
 - Pump refurbishment and service exchange facilities
-

Mono Pumps Around the World

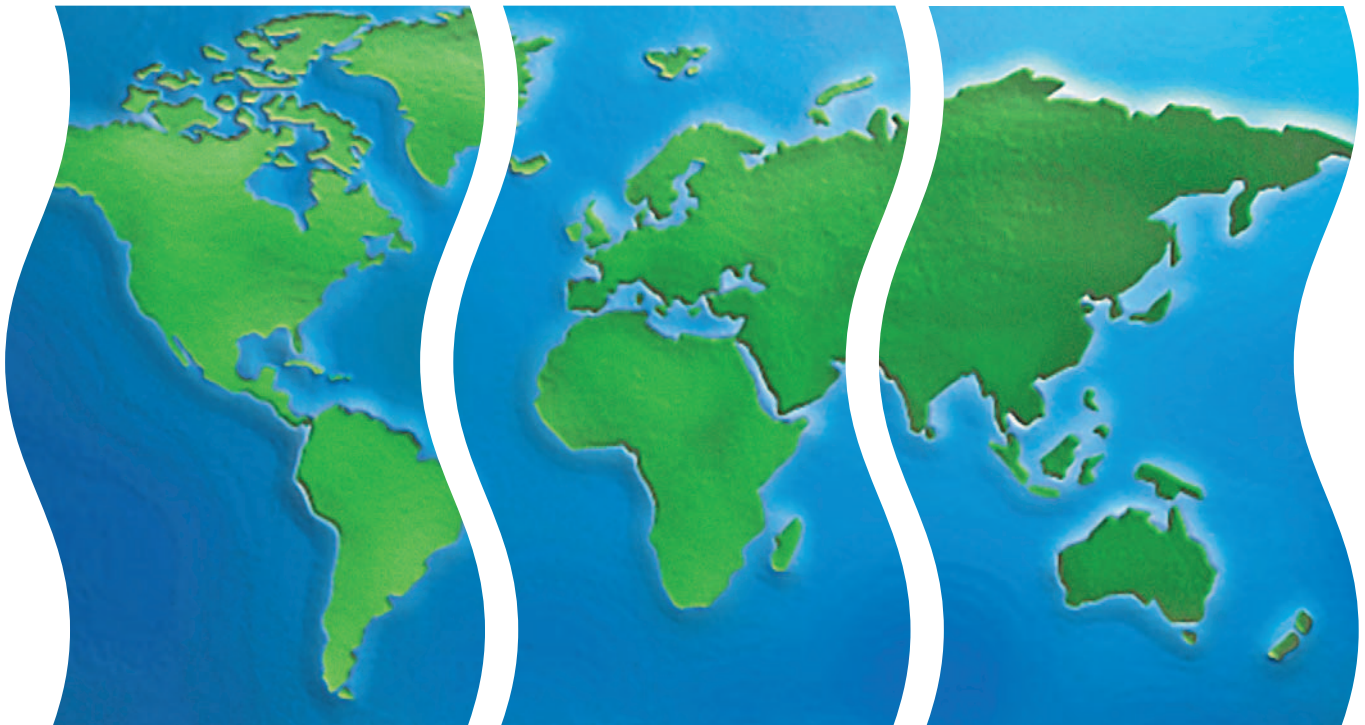

Americas

Monoflo Incorporated
16503 Park Row
Houston
Texas 77084
U.S.A.
Tel: +1 281 599 4700
Fax: +1 281 599 4733
E-mail: inquire@monoflo.com
www.monoflo.com

Europe

Mono Pumps Limited
Martin Street
Audenshaw
Manchester M34 5JA
England
Tel: +44 (0)161 339 9000
Fax: +44 (0)161 344 0727
E-mail: info@mono-pumps.com
www.mono-pumps.com

Australasia

Mono Pumps (Australia) Pty Ltd
338-348 Lower Dandenong Road
Mordialloc
Victoria 3195
Australia
Tel: +61 (0)3 9580 5211
Fax: +61 (0)3 9580 9036
E-mail: ozsales@mono-pumps.com
www.mono-pumps.com

Your local Authorised Distributor:



Please contact the nearest Mono Office for details of your local authorised distributor.

Published information other than that marked CERTIFIED does not extend any warranty or representation, expressed or implied, regarding these products. Any such warranties or other terms and conditions of sales and products shall be in accordance with Mono Pumps Limited standard terms and conditions of sale, available on request.

© Mono Pumps Limited March 2003.
Mono® and Flexishaft® are registered trademarks of Mono Pumps Ltd
Registered in England No 300721

SLMP/012/01/R5

Mono Pumps (New Zealand) Ltd

P.O. Box 71-021
35 - 41 Fremlin Place
Avondale, Auckland 7
New Zealand
Tel: +64 (0)9 829 0333
Fax: +64 (0)9 828 6480
E-mail: ozsales@mono-pumps.com
www.mono-pumps.com

National Oilwell Inc.

Rm 2303 Capital Mansion
No. 6 Xin Yuan Nan Road
Chaoyang District
Beijing 100004
P.R. China
Tel: +86 (0)10 6461 1115
Fax: +86 (0)10 8486 8481
E-mail: alan.chen@natoil.com
www.mono-pumps.com

Mono Pumps Ltd
Martin Street, Audenshaw
Manchester M34 5JA England
Tel: +44 (0)161 339 9000 Fax: +44 (0)161 344 0727
e-mail: info@mono-pumps.com
www.mono-pumps.com

Mono®

A National Oilwell® Company