



SPL314/C/TRC3-DO/GL

CODING METHOD				
PRODUCT CODE	FIXING METHOD	SLAT MATERIAL	METAL FINISH	OTHER
SPL 314	C	TRC3-DO	GL	

* Technical drawings not to scale

NOTE-

- * Ground anchorage can be provided if required.

This product is site specific and can be designed to meet the individual requirements of any project.

The image shown is an illustration of the type of structure we offer.

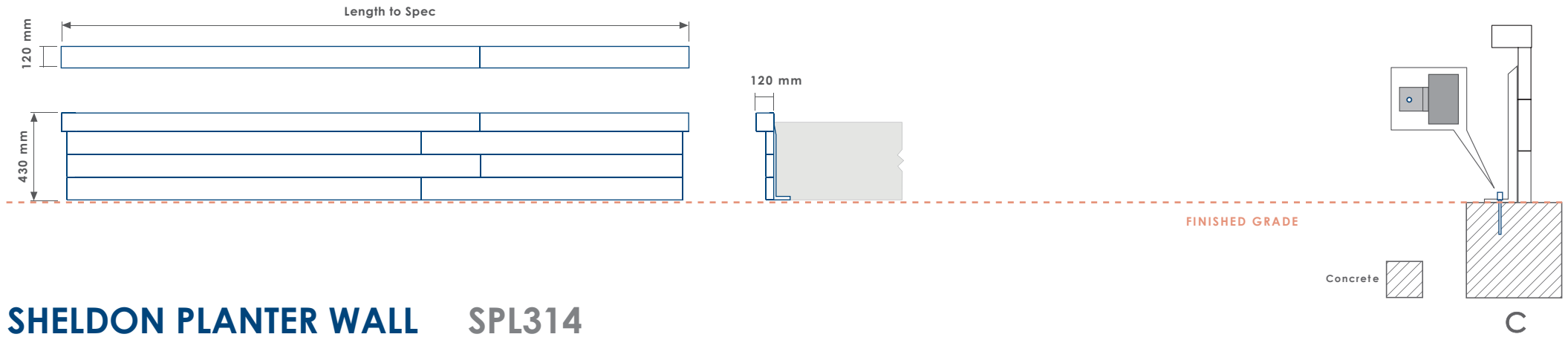

SHELDON PLANTER WALL SPL314

PRODUCT DIMENSIONS		HEIGHT	430 mm	LENGTH	to spec	WIDTH	120 mm	WEIGHT		CAPACITY		SEAT HEIGHT		OTHER		
FIXING OPTION	Direct Embedment/Root Fix	A		SLAT MATERIAL	Treated Redwood Class 3 Unstained	TRC3	<input type="checkbox"/>	METAL FINISH	Aluminium Powder Coated	APC	<input type="checkbox"/>	CONCRETE COLOUR	Concrete Colour - Light Grey	LG	<input type="checkbox"/>	
	Below Finished Grade Base Fix	B			Treated Redwood Class 3 Stained Dark Oak	TRC3-DO	<input checked="" type="checkbox"/>		Galvanised	GL	<input checked="" type="checkbox"/>		Concrete Colour - White	WT	<input type="checkbox"/>	
	Surface Mount	C	<input checked="" type="checkbox"/>		Treated Redwood Class 4 Unstained	TRC4	<input type="checkbox"/>		Galvanised and Powder Coated	GPC	<input type="checkbox"/>		Concrete Colour - Buff	BF	<input type="checkbox"/>	
	Plinth Mount - Buff Exposed Aggregate	D-BEA	<input type="checkbox"/>		Treated Redwood Class 4 Stained Dark Oak	TRC4-DO	<input checked="" type="checkbox"/>		Zinc Plated and Powder Coated	PPC	<input type="checkbox"/>		Concrete Colour - Black	BK	<input type="checkbox"/>	
	Plinth Mount - Buff Granite	D-BG	<input type="checkbox"/>		Treated Softwood Unstained	TS	<input type="checkbox"/>		Stainless Steel	SS-304/316	<input type="checkbox"/>		Concrete Colour - Red	RD	<input type="checkbox"/>	
	Plinth Mount - Grey Granite	D-GG	<input type="checkbox"/>		Douglas Fir	DF	<input checked="" type="checkbox"/>		TOP TYPE	Apex Top	AT		<input type="checkbox"/>	Concrete Colour - Standard Grey	SG	<input type="checkbox"/>
	Free Standing	FS	<input type="checkbox"/>		FSC Hardwood Iroko	HI	<input checked="" type="checkbox"/>			Chamfer Top	CT		<input type="checkbox"/>	Concrete Colour - Non Standard	NS	<input type="checkbox"/>
	Free Standing with Base Weight	FS-BW	<input type="checkbox"/>		Recycled Plastic - Black	RP-BK	<input type="checkbox"/>			Dome Top	DT		<input type="checkbox"/>	Concrete Finish - Dressed Finish	DS	<input type="checkbox"/>
	Wall Mount	WM	<input type="checkbox"/>		Recycled Plastic - Grey	RP-GY	<input type="checkbox"/>			Flat Top	FT		<input type="checkbox"/>	Concrete Finish - Satin Shine	SH	<input type="checkbox"/>
	Non Standard	NS	<input type="checkbox"/>		Recycled Plastic - Green	RP-GN	<input type="checkbox"/>			Open Top	OT		<input type="checkbox"/>	Concrete Finish - Deluxe Polish (top)	DP	<input type="checkbox"/>
To BREEAM Standard	B06/B08	<input type="checkbox"/>	Recycled Plastic - Brown	RP-BR	<input type="checkbox"/>	Slant Top	ST	<input type="checkbox"/>		Concrete Finish - Textured Finish	TF	<input type="checkbox"/>				