

1



Section 1
Traffic Management
Temporary Signage
Roadworks Equipment

Section 2
Highway Maintenance Products

Section 3
Pedestrian Guardrailing
Crash Barriers & Fencing

Section 4
Decorative & Amenity Bollards

Section 5
Amenity & Street Furniture

Section 6
Car Parks & Access Control

Cones, Cylinders & Lamps	2
Custom-Made Signs	3
Chapter 8 Temporary Signs	4-5
Portable Barrier Systems	6-7
Traffic Separators	8
Automatic Stop-Go Boards & Temporary Traffic Lights	9-10
Cable Protectors	11
Workman Tents	12
Vehicle Accessories	13-15
Measuring Equipment	15
Cable & Pipe Locators	16-18
P.P.E. Hi-Visibility Clothing	19
Head Protection	19
Fall Arrest Equipment	20
Tapes	21
Emergency Cable Cover Bollards (Darleks)	21
Temporary Lining & Road Studs	21
Spill Management	22
Tarmac Road Repair	23

► Cones, Cylinders & Lamps

► Recycled cone

- Our most popular cone.
- 450mm fitted with DES2 cat sleeve
 - 750mm self-weighted



50cm No Waiting Dominator

Mark II Plain

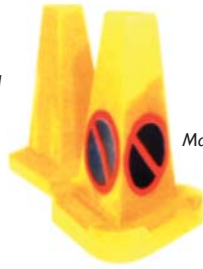

Mark II



Mark III

◀ No waiting cones

- Recycled
- Two-piece 500mm
- Tri-sided

► Two-piece cones

- Fitted with DES2 cat sleeve
- Heavy recycled base for good stability
- Excellent for staking
- Totally complies with BS873
- Available in 500mm, 750mm & 1000mm



▼ Traffic cylinders and bases



Unibase



Glue Mat



Concrete Fixing Bolts

Asphalt Fixing Bolts

▼ Temporary road studs

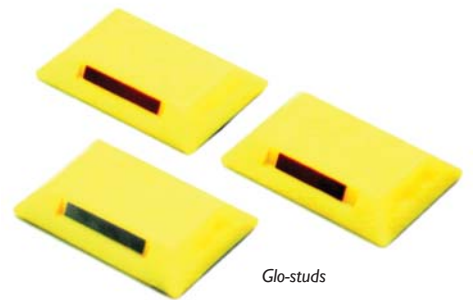

Glo-studs



Glo-Post
75cm/30" and 45cm/18" heights available



Springback Cylinder Post with Unibase
75cm/30" and 45cm/18" heights available

▼ Flashing lamps



Microlite 2



Minilite



Lamp Cone Bracket



- ◀ •Special signs
- Information boards
- Diversion routes
- Apology boards
- Scheme boards



Available as:
 Plate only - Zintec - Foamex - Corex
 With freestanding frame
 With channel for post mount

Common sizes:
 600 x 450mm
 1050 x 750mm
 1200 x 1200mm

▶ Information board

An information board must be displayed at every site, except for mobile works and minor works which do not include excavation, involving use of a vehicle. This board should be placed so that it does not obstruct footways or carriageways but can be read mainly by pedestrians, and possibly by drivers who have stopped. (The boards are too detailed to be read easily by passing traffic.)

The board must give the name of the organisation for which the works are being carried out, and a telephone number which can be contacted in emergencies. It may also contain other information that will be helpful in explaining to the public why the work is being done, who is doing it and how long it will take. Such additional information is to be encouraged where practical and could include some or all of the following: a brief description of the works, the name of the contractor and a message apologising for inconvenience or delays. A completion date should normally be included if the works are expected to continue for more than a month.



Chapter 8 Temporary Signs

Basic essential temporary signs for roadworks



Road works ahead



Road narrows on left-hand side ahead



Road narrows on right-hand side ahead



Keep right



Keep left



Traffic cone



Road danger lamp



Pedestrian barrier



Traffic barrier ('Lane closed' sign)



End of road works

Single file traffic	Single file traffic			Note: A plate must be used with this sign	Overhead works	Surveying	Max speed 20	800 yds	
For 1 mile	For 1 mile		For 1 mile		For 1 mile	For 1 mile	For 1 mile	800 yds	100 yds
800 yds	800 yds	800 yds			800 yds	800 yds	800 yds	800 yds	
250 yds	250 yds	250 yds			250 yds	250 yds	250 yds		

Some permitted combinations of the signs and plates

Road narrows on both sides ahead	Traffic signals ahead	Where vehicles should stop at temporary signals	Traffic control ahead	Stop/Go boards		Priority to vehicles from opposite direction	Priority over vehicles from opposite direction
Other danger ahead (use only with a plate)	Slippery road	Traffic cylinder	High intensity flashing beacon	Sharp deviation to the right	Direction of temporary pedestrian route	Stop Works	Traffic signals not in use
Temporary road surface	Zebra or signal controlled crossing is not in use	Loose chippings	Ramp ahead	Ramp	Left-hand lane of a dual two-lane carriageway road closed	Left-hand lane of a dual three-lane carriageway road closed	Centre lane of a three-lane two-way road closed
Cyclists dismount	Setting out road works ahead	Single file traffic	Overhead cable repairs	For 1 mile	1 mile	250 yds	Maximum speed advised
				Distance over which hazard or prohibition extends	Distance to hazard or obstruction	Distance and direction to hazard or obstruction	

Other signs you may need

Large range of temporary signs kept in stock

SAFETY AT STREET WORKS AND ROAD WORKS

A CODE OF PRACTICE



Sign details reproduced by kind permission from Safety at Street Works and Road Works (HMSO).

▼ Quickfit System

- Signs can be provided on aluminium or polyplate for the Quickfit interchangeable system.
- Class 1 or 2.
- This system is larger and more robust than standard angle iron framed signs.

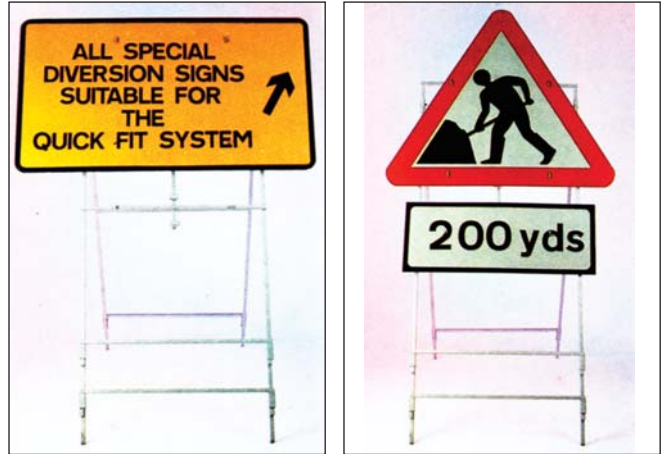

▼ Metal angle iron frames



◀ Roll up signs

- One-piece unit
- Very easy to erect
- Sign faces reflective to BS873 Class 2. Non-reflective and BS873 Class 1 also available on request
- 5 different sizes available
- Can be printed with any road sign design from UK or overseas spec
- Rust-proof metalwork
- Suitable for use in temperature range -5° to +30°. Lower and higher temperature resistant product also available on request

▶ Cone signs

- Available in 600 and 750mm sizes
- Totally plastic
- Simply fit onto 750mm/1mtr cones with integral bracket
- Very light in weight
- Minimum of storage space required
- Ideal for vehicles with limited space and weight problems



Road works traffic cone sign



Keep right traffic cone sign



Traffic cone sign back view

► Portable Barrier Systems (Chapter 8)

Portable Pedestrian Barriers, which may include mesh, should be reasonably rigid, designed to resist being blown over by the wind or passing traffic, and have:

- A handrail fixed at between 1 metre and 1.2 metres above ground level, which should be reasonably smooth and rigid to guide pedestrians and give them some measure of support; and a visibility panel of at least 150mm deep which may be integral with the handrail or, if separate, must be fixed so that its upper edge is a minimum of 0.9 metres above ground level.
- A tapping rail (or equivalent reasonably rigid area if the barrier is a vertically continuous one) of minimum depth of 150mm with a lower edge at ground level or set at up to 200mm above ground level.

▼ Titan barrier 2-metre and 1.5-metre



1.5 metre Titan barrier



2 metre Titan barrier



► **2-metre Stakka barrier**

The new generation of popular one-piece Chapter 8 barrier systems.

Features and benefits in common are:

- Foldaway feet - easy to stack
- One-piece lightweight - good for handling
- Connectivity - for stability
- Adaptable - can accept lights and signs



▼ **Smaller manhole barrier sets**

Highly portable systems.



Hazard Moorgate barrier



Hazard Moorgate barrier - black chevron



Moorgate barrier 3 gated



Manhole kit



Champion manhole barriers - available in three designs

► **Cone barrier system**



75cm Roadhog slotted barrier



75cm slotted two-part cone barrier



Mark V cone converter fits Fleximan end-capped boards



Mark V cone converter fits Turret end-capped boards

▼ **Temporary barrier systems**



JWeb fencing



Bodyline base

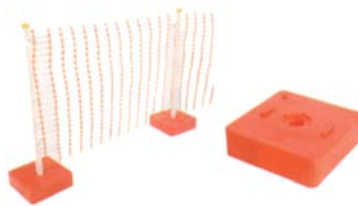

JWeb fencing with JWeb upright and sand-filled base



Metal fencing support pins (do not comply with Chapter 8)



Zebra tape

► Traffic Separators

► Utility traffic separator

Available in two different lengths and several colour options, the Utility is highly versatile. It is sturdy enough for use in permanent situations if required or it can form a roundabout with a diameter of 4.5m upwards.

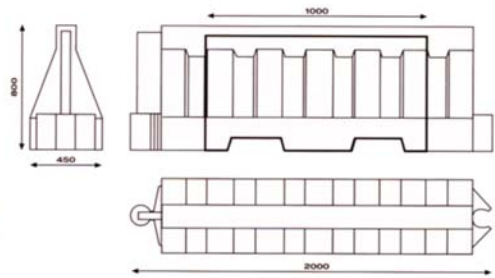

- Integral linkage system negates the need for pins or bolts
- Easy to assemble jigsaw fixing
- Lightweight for easy transportation and positioning
- Maintenance free
- Optional logos and colours available at extra cost
- Can be part filled with sand, gravel or water



▼ Pozecone traffic separator

The innovative design of the Pozecone combines a traffic cone and traffic kerb into one unit. It is totally unique and highly cost-effective.

Ideal for use as a safety barrier, it can equally be utilised for traffic management purposes. A spacer unit and corner piece make this system exceptionally flexible for all locations.

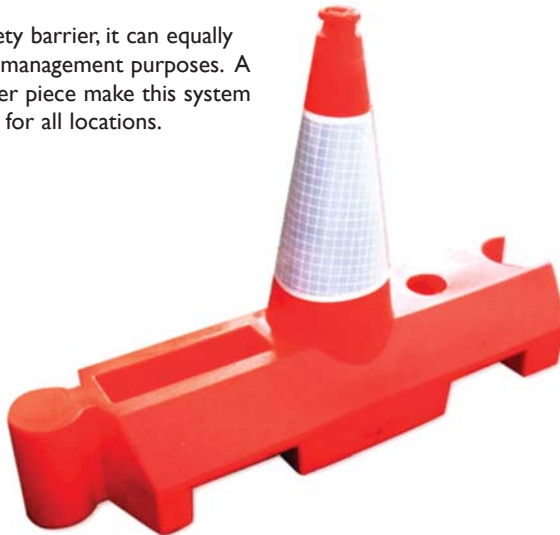

- Exceptional stability in poor weather conditions
- Much higher visibility than standard cones
- Positive fixing
- Tough, durable one-piece moulding with integral jigsaw fixing
- Can be filled with either sand or water
- Stackable for easy transportation and storage
- Handle recess for either forklift or manual handling
- Standard D2 sleeve, other options available

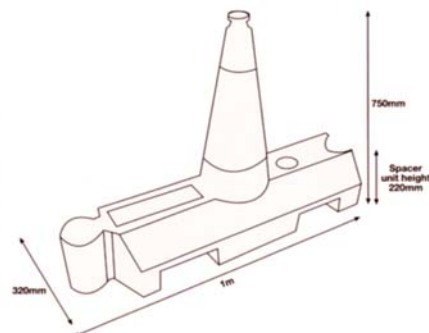

Automatic Stop-Go Boards & Temporary Traffic Lights ◀

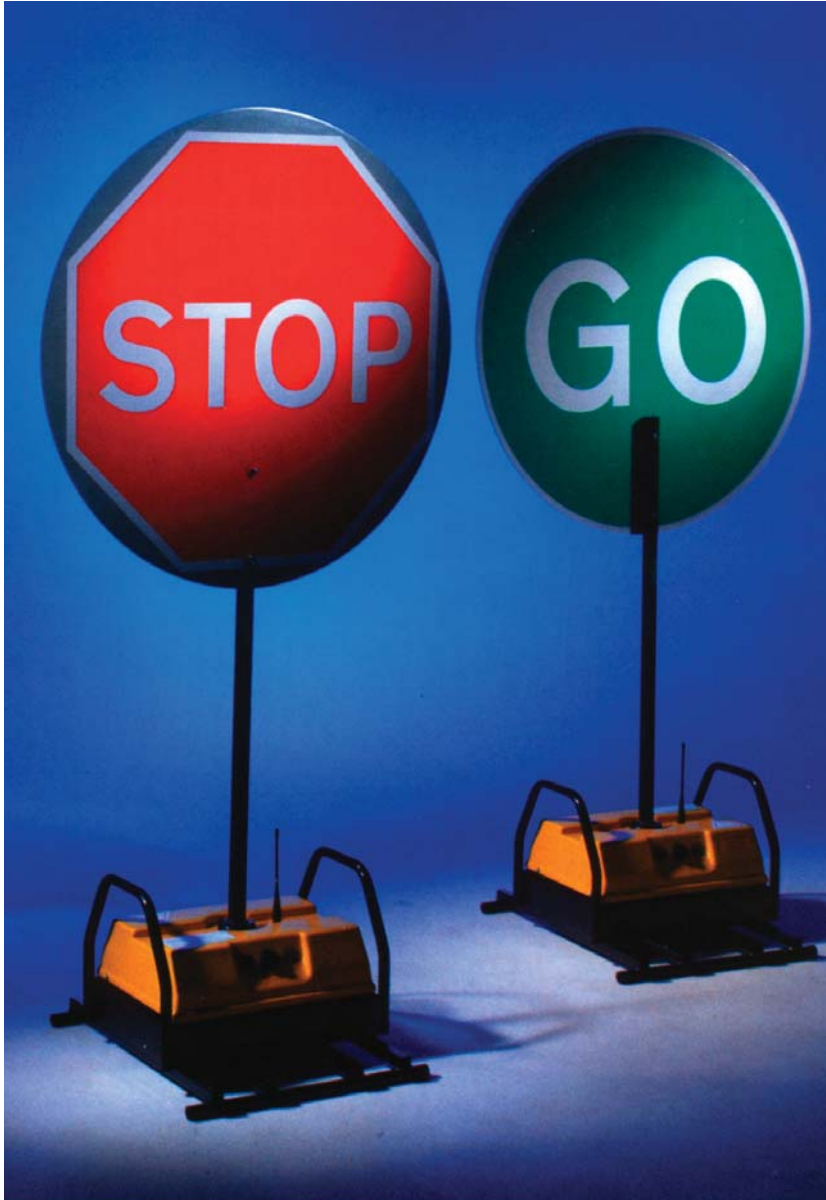

◀ ▼ Robo Sign

Remotely controlled Stop-Go temporary traffic control system. The Robo Sign greatly increases operator safety and reduces labour costs. Compact, easy to transport, operational within minutes and very simple to operate. The complete system comprises two identical base units and one hand-held radio remote control unit with battery belt power pack and charger.

Robo Sign incorporates patented state of the art technology and the robust design is recognised for its efficiency, reliability and durability. The system is fully approved by the Department of Transport.

- **Labour saving:** Just one operator is required to manage and control the traffic flow at both ends of the work zone.
- **Radio controlled:** Eliminating the need for cables links. The hand held radio control unit has a single press mechanism that activates one or other of the Stop-Go signs (from stop to go and vice versa).
- **Easy to Transport:** Each base unit weighs approximately 30 kilos and the Stop-Go boards are detachable for easy handling and storage. The whole system is compact enough to be carried in a small commercial vehicle.
- **Quick set up:** Installed and ready to operate in minutes.
- **Safe operation:** The rapid remote control feature allows the operator to work from a safe vantage point out of the direct line of traffic. The system also provides the capability to display a continuous stop signal at both ends of the work zone to allow for works vehicle movements or in case of any emergencies within the work zone.
- **Battery powered:** Each Robo Sign base unit has an in-built rechargeable battery supply and up to 400 hours continuous operation when fully charged. The remote control unit's battery pack provides up to 100 hours continuous operation.



► ▼ Masterhead XL traffic signals

Lightweight free-standing 2-phase radio linked traffic signals. Masterhead XL is designed to provide simple and safe traffic control. Taking the development of the standard Masterhead traffic signal system onto another dimension, it utilises the latest cableless technology incorporating XL controllers - conveniently located in the rear of the two signal heads, with each one powered by a small portable 12-volt battery supply. These free-standing signals also offer the flexibility of being easily transported in a small commercial vehicle.

The Masterhead XL system represents the latest in portable signal technology with the benefit of no interconnecting cables. Totally silent in operation and very quick to set up, the system is also easy to transport.

- **Reliable and low maintenance:** Each part of the Masterhead XL signal system has been designed to operate in a harsh environment. The use of engineering plastics provides a lightweight yet robust solution. Components and sub-assemblies were chosen for reliability and designed to reduce maintenance time.
- **Built-in controller:** Each Masterhead signal is fitted with an XL controller - compact and proven with the flexibility of being used as master or slave. With clear menu-driven operation instructions and a unique, quick set up option. For greater security and weather protection, a lockable steel door protects each controller.
- **High performance LED optics:** A standard feature on the Masterhead XL, the LED optics prolong battery life or allow the use of smaller and lighter battery packs. LED reliability dramatically reduces maintenance costs and is specifically designed for use in harsh environments. They are also fully 'type approved' by the UK Highways Agency.
- **Vehicle actuation:** Latest generation 'type approved' microwave vehicle detectors used for each head and mounted above the red aspect and protected by the full length steel shroud.



Rubber bridges

Street Furnishings cable protectors help create a safer environment in your workplace, either in the office or on the shopfloor. With a wide range of profile sections available, they help you comply with Health & Safety requirements and play a major role in preventing accidents caused by loose, trailing cables, air lines or hose, etc.

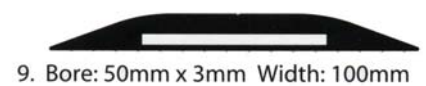
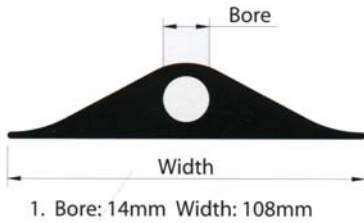
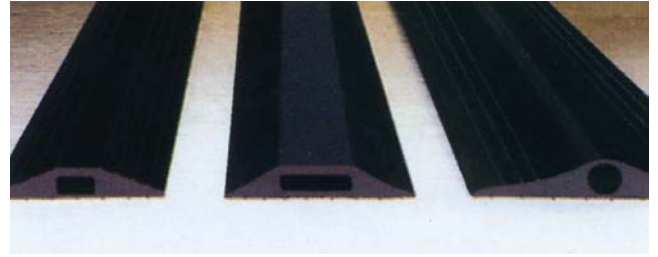

Speed tent - square



Model 180 5ST (2 zips) pictured above
Fold away size 1.4m x 0.3m
Erect in just 10-15 seconds



Erection demonstration (model 1805SN)

Standard specifications:

- Translucent PVC reinforced flame-retardant - allows 96% of light into work area
- Smooth wipe-clean cover
- Robust die cast central joints
- Fibreglass framework
- Non-conductive
- Guy lines
- All spares available and tent repairs
- No loose components

Additional options:

- Additional lower section colours - white, blue, black, green
- PU coated nylon
- Heavy duty carry bag
- Additional front and rear zips
- Rear door entrance
- Windows

Speed tent - dimensions and weights		
Type	Size	Weight (Kg)
100 5ST	1.0 x 1.0 x 1.7m (3.5 x 3.5 x 5.5ft)	7
140 5ST	1.4 x 1.4 x 1.7m (4.5 x 4.5 x 5.5ft)	8.5
180 5ST	1.8 x 1.8 x 2.0m (6 x 6 x 7ft)	13
210 5ST	2.1 x 2.1 x 2.0m (7 x 7 x 7ft)	15
250 5ST	2.5 x 2.5 x 2.0m (8 x 8 x 7ft)	20
300 5ST	3.0 x 3.0 x 2.2m (10 x 10 x 7ft)	25
Carry bag details		
CB11	HD carry bag	Up to 7ft
CB12	HD carry bag	8ft to 10ft

Site tent

- Translucent white
- PVC reinforced flame-retardant cover material
- Waterproof
- Economic
- Hardened aluminium frame
- Easy to pull apart and assemble slip joints
- Zipped door
- Collapsible with storage bag
- Peg down and skirting designed
- Cover to frame security with Quick Fix buckle fixings
- Guy lines included
- Company logo can be added
- Cover material and colour choice available

Site tent - dimensions	
Type	Size
100 ST	1.0 x 1.0 x 1.8m (3.3 x 3.3 x 6ft)
140 ST	1.4 x 1.2 x 1.8m (4.5 x 4 x 6ft)
180 ST (butt fusion)	1.8 x 1.8 x 2.3m (6 x 6 x 7.5ft)
300 ST	3.0 x 3.0 x 2.3m (10 x 10 x 7ft)



Storage bag

▶ Jerricans & fuel cans

A range of traditional mild steel jerricans painted externally and coated internally for fuel and water resistance. All sizes are of UN approved standard and specification and are suitable for water, petrol, diesel, etc.

▶ SF-JC05A jerrican

- 5 litre capacity
- Dimensions 125 x 220 x 275mm
- Weight empty 1.7kg

▶ SF-JC10A jerrican

- 10 litre capacity
- Dimensions 130 x 390 x 280mm
- Weight empty 2.9kg

▶ SF-JC20A jerrican

- 20 litre capacity
- Dimensions 155 x 465 x 345mm
- Weight empty 4.4kg

▶ SF-JCSF jerrican spout

- Metal flexible clamp-on pouring spout 280mm long
- Integral gauze filter
- Available as an optional extra
- Fits SF-JC05A, SF-JC10A, SF-JC20A

▶ SF-JCSFA jerrican spout

- Metal flexible clamp-on pouring spout 260mm long
- Integral 'non-glug' air tube
- Integral gauze filter
- Available as an optional extra
- Fits SF-JC05A, SF-JC10A, SF-JC20A

▶ SF-JCSR jerrican spout

- Metal rigid clamp-on pouring spout
- 180mm long x 30mm bore (i.d.)
- Integral 'non-glug' air tube
- Available as an optional extra
- Fits SF-JC05A, SF-JC10A, SF-JC20A



▶ Wheel jacking skates (JWS)

Wheel skate and jack combined to 'lift and shift' any car in seconds without any power requirement. Effortlessly expands to fit the wheel and the pedal-operated, twin-roller jack raises the car with ease. Ideal for vehicle showrooms, bodyshop, repair workshop, car parks, etc.

- Fits tyres up to 10" (25cm) wide
- 4 heavy duty castors for complete manoeuvrability
- Capacity 1250lbs (570kgs)
- Weight 24kg



▶ Rotating BarLite

Specification:

- Direct drive through durable rubber ring, from high quality DC motor ensures quiet, smooth running and efficient operation
- 2 central 'V' mirrors for optimum light output
- 12 & 24 volt options available
- Magnetic with suction pads or 2-bolt fixing
- Available in amber
- Computer designed tough polycarbonate lens
- On dual voltage beacons the desired voltage is achieved by changing the bulb (i.e. 55 watt - 12 volt quartz halogen bulb; 70 watt - 24 volt quartz halogen bulb)

Fixing applications:

- Magnetic with suction available on all BarLites. The magnet is encased in the rubber base mat which offers suction for additional grip and prevents scratching the vehicle
- Bolt fixing - 2 bolts
- DIN mounting post available for 12v, 24v and ECE 65 approved



▶ Car beacon

- Traffibeacon 12v amber
- Magnetic base/suction pad
- Rotating halogen bulb
- Fits cigar lighter socket
- Xenon beacons have double hit flash maximising 'on time' and giving better visibility



▼ Motorway/Highway maintenance signs

Wide range of self-adhesive, self-cling and magnetic signs for cars. We also supply magnetic company detail signs for vans.



▼ Waxproofed jute tarpaulin

454/624g (16/22oz). Complete with brass eyelets, ropes and strengthened patches at 137-152cm (54-60") intervals. A general purpose cover where waterproofing is not the main criteria



► Sandbags

Supplied empty.

Polypropylene: size 800 x 330mm (31 x 13") approx.

Hessian: Unproofed 213g (7.5oz), size 800 x 330mm (31 x 13") approx.

► Heavy duty hessian

283g (10oz), sizes 0.91 x 100m (3 x 328') approx or 1.78 x 100m (6 x 328') approx.

► Polypropylene rope

Sizes 8mm or 12mm.

► Draw cord rope (drum)

6mm polypropylene rope on drum. Ideal for use as draw rope. Length 500m.



Measuring Equipment ◀

► 5000 Road measurer

Set the world standard for accuracy and precise handling. Superbly balanced - the first choice of professionals worldwide. Approved by many Weights & Measures Authorities worldwide and by the United States National Transportation Safety Board (USNTSB) for accident investigation.

- Industry standard
- Folding handle
- Lever resets to zero
- Precise measurement
- Brake and mud scraper
- Stand folds away when not in use
- Supplied complete with carry case
- Clear easy-to-read display with large 7mm high characters



Dual reading model also available (5002)



► Cable & Pipe Locators

Avoidance Scan™

Search in Power, Radio, and Genny modes simultaneously for improved safety and faster surveys.

StrikeAlert™

Alerts the user to shallow power cables by flashing an alert icon.

Precision locate

Improved pinpointing of buried services and exceptionally fast sound and meter response.

Optimised locate

Operates effectively in congested sites, and sites with overhead cables.

► C.A.T & Genney cable & pipe locator

Introducing a new generation of products with ground breaking features - delivering improved safety, faster surveys and simpler operation.

Buried utilities represent a major hazard to construction workers the world over. Poorly planned excavations can cause cable or pipe damage resulting in costly repairs, delays and personal injury.

The C.A.T and Genney range is designed to locate these services so that they can be avoided.

The C.A.T (Cable Avoidance Tool) can detect signals naturally radiating from metallic services or the Genney can be used to apply a distinctive signal that the C.A.T can detect.

The C.A.T and Genney has become the industry standard pipe and cable avoidance tool, recognised as the leader providing performance, ruggedness and reliability, together with affordability and low cost of ownership.

The C.A.T³ is the latest in a line of continuous improvements. The C.A.T³ utilises the latest technologies to bring you the most optimised cable avoidance tool in the market place today.

AvoidanceScan™

This new feature allows the user to sweep an area searching for power, radio and Genney signals simultaneously, dramatically speeding up pre-dig survey times and encouraging the full use of all three modes reducing costs and improving safety.

StrikeAlert™

Although work practices and guidelines insist power cables are buried below a certain depth, a common cause of cable strike is shallow cables. The StrikeAlert™ feature alerts the user to shallow power cables by flashing the ALERT icon on the display of the C.A.T³V or C.A.T³+

Locate quality

Cutting edge technology within the new C.A.T³ ensures fastest possible processing of data. This has resulted in exceptionally fast sound and meter response, improved precision pinpointing together with a smoothness that puts the user in complete control.

Enhanced signal processing

Latest and patented signal processing techniques have given the C.A.T³ the ability to reject unwanted signals to a level never achieved before. This has optimised the C.A.T³ for operation in the most demanding of environments such as congested sites and sites with overhead electrical cables.

Backlight

Poor light conditions can lead to misread information from the meter. The auto switching backlight minimises these effects and allows the continued use of the C.A.T³ into the night.

Pulse/continuous switch on Genney

This switch allows the user to select the setting to their individual preference and to optimise battery saving. The new Genney is compatible not only with all the different versions of 33kHz C.A.T³ but also all previous versions of 33kHz C.A.T.

Real sound

'Real Sound' means the sound you hear is derived from the signal radiating from the cable or pipe. With very little experience this very important feature helps the user distinguish the signal from random background noise.

Batteries

Fed up with fumbling around with eight AA cells? Well the new C.A.T³ uses just two D cells giving maximum use at minimum costs. Compatibility with the Genney batteries means that you only need buy one type of battery increasing convenience and reducing stock levels. New battery low indicator alerts when battery is getting low.





In the P mode the C.A.T³ detects 'power' signals that are being radiated by loaded cables.



In the R mode the C.A.T³ detects VLF radio signals re-radiated by buried metallic pipes and cables.



In the G mode the C.A.T³ detects a tone radiated by the Genny+ to a buried conductor.



In AvoidanceScan™ mode P, R and G operate simultaneously providing faster surveys.



DETACHABLE LOUDSPEAKER FOR NOISY CONDITIONS

AUTO BACKLIT LCD

BAR GRAPH FOR SIGNAL STRENGTH

UTILITY DEPTH BUTTON

TRIGGER SWITCH - SWITCHES OFF AUTOMATICALLY, WHEN NOT IN USE

SENSITIVITY CONTROL

MODE SELECTOR SWITCH

LIGHTWEIGHT, ALL-WEATHER, HI-IMPACT ABS

BATTERY COMPARTMENT

REPLACEABLE WEARFOOT

► Cable & Pipe Locators *(continued)*

► C.A.T & Genney cable & pipe locator (cont'd)

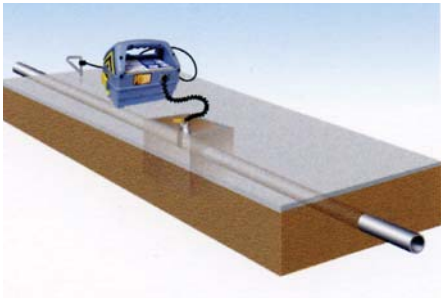

DIRECT CONNECTION

A very effective method for connecting to a valve, meter, junction box or other access point. Curly leads are compact and easier to handle and pack away.

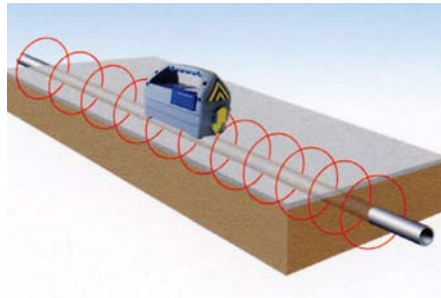

INDUCTION

A convenient and quick way of applying the Genny³ signal to pipe or cable, where direct connection or signal clamping is not possible

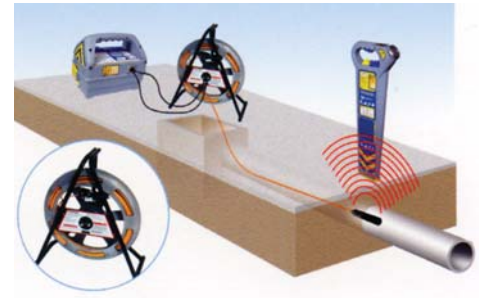

FLEXITRACE (Optional)

A self-contained flexible rod and transmitter alternative for tracing non-metallic pipes. Energised by connecting to the Genny³. The small diameter transmitting head allows access to very small diameter pipes of 15mm or above.

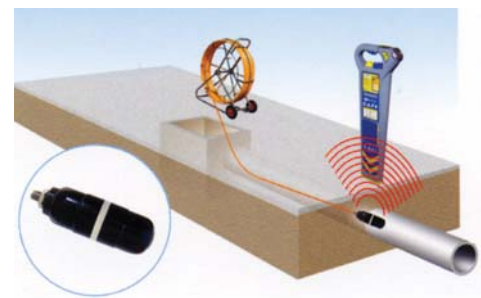

MOUSE (Optional)

The mouse is a self-contained transmitter which is connected to a push rod and inserted into a non-metallic pipe or duct structure. The mouse can then be detected using the C.A.T².

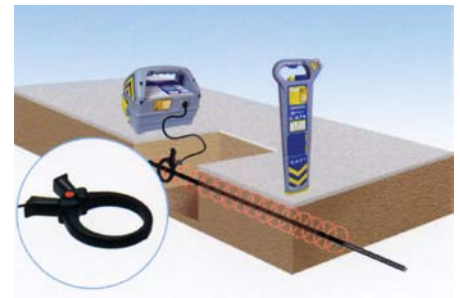

SIGNAL CLAMPING (Optional)

Applies a Genny³ signal safely to a pipe or live cable up to 76mm diameter without interrupting the supply.



LIVE CABLE CONNECTORS (Optional)

For applying the transmitter signal to a live cable - the most certain method of locating a power distribution system in a street.



▼ Polyester waistcoat

- EN471 Class 2
- Velcro fastening at front
- Reflective tape to EN471 Class 2



▼ Polyester long-sleeve jerkin

- EN471 Class 3
- Velcro fastening at front
- Reflective tape to EN471 Class 2
- For use on dual carriageways or roads with a speed limit of 50mph plus



▼ Waterproof jacket

- EN471 Class 3
- Fully taped seams
- Two-way heavy-duty zip
- Concealed hood
- Two outer, one inner
- Reflective tape to EN471 Class 3



▲ Mini vest

- EN471 Class 1
- 100% polyester
- Stud fastening at front
- Shoulders and sides pull apart for anti entanglement

▲ Waistcoat

- EN471 Class 2
- To London Underground specification
- 100% polyester
- Stud fastening at front
- Velcro fastening at shoulders and sides
- Velcro at sides enables size adjustment



▲ Standard hard hat

Available with company logo.

▶ Hard hat baseball cap



► Fall Arrest Equipment

► ▼ Britannia harness

All 'Fall Arrest' harnesses are manufactured from the highest quality materials that exceed the requirements of legislation, are comfortable to wear and easy to put on and take off. They should be used in conjunction with fall arrest lanyards (max 2m) or other compatible fall arrest devices.

Britannia Basic pictured



▼ Lanyards

All fall arrest lanyards incorporate the unique 'NRG' energy absorber which in the event of a fall will activate and reduce the forces on the body to well below the European standard requirements of 6 Kn.

The full range of lanyards are manufactured in either polyester webbing or nylon rope and available with a wide range of karabiners or connectors in varying lengths up to a maximum of 2m.



Stretch Lanyard
SF-90227 - 1.8m
SF-90227SC - 1.9m
SF-90227SCA - 1.9m



Standard Lanyard
SF-90211 - 1m
SF-90147 - 1.5m
SF-76050 - 2m

Details of the entire range of harnesses available on request.

Harness specifications

Ref	Product	Polyester webbing	Part elasticated webbing	Metal parts steel	Shoulder strap adjustment	Chest strap adjustment	Leg loop adjustment	Rear attachment	Front attachment	Side attachment	Confined space attachment	Sit attachment	EN 361	EN 358	EN 1497	EN 813	Weight
SF-90018	2000	●		●		●	●						●				0.74
SF-90046	Britannia Basic	●		●		●	●						●				1.05
SF-90034	Britannia 2020	●		●		●	●	●					●				1.24
SF-90099	Britannia FRS	●		●	●	●	●	●					●				1.39
SF-90086	Britannia Plus	●		●		●	●		●				●	●			1.69
SF-90049	Britannia Super	●		●		●	●	●	●				●	●			2.05
SF-90245	Britannia Basic "Lastic"	●	●	●		●	●						●				1.10
SF-90251	Britannia FRS "Lastic"	●	●	●		●	●	●					●				1.38
SF-90260	Britannia Super "Lastic"	●	●	●		●	●	●	●				●	●			2.04
SF-90024	Zenith II	●		●		●	●	●	●		●		●	●		●	1.80
SF-90088	Britannia FRS/Rescue	●		●	●	●	●	●		●			●		●		1.52
SF-90096	Britannia Bolero	●		●	●	●	●	●		●			●		●		1.68

▼ Tapes



Caution tape



Police warning tape



Underground warning tapes

▼ Emergency Cable Cover Bollards (Darleks)

Designed to provide a highly visible warning of either exposed live cables or damaged Keep Left bollard. Each cover features sand ballasted base for added stability and integral handle to help siting.

Specification
 Height: 1170mm
 Base: 710 x 710mm (hexagonal)
 Weight: 17.2 Kgs (sand ballasted)



► Temporary lining

White and black available.

► Temporary road studs

Hot melt/self-adhesive.



▼ Trench covers and ramps



► Spill Management

▼ Emergency kit in bag

An emergency spill kit packaged in a sturdy waterproof bag which is easy to store and can be carried to the location of the spillage. Kits are colour coded and available for oil or chemical spillages of 35 litres.



◀ Oil Spill 35 & Oil Spill 35 Deluxe

Suitable for tankers, diggers and all construction vehicles.

Contents:

- 1 Bag
- 4 Socks to absorb oil
- 25 Pads to soak up oil
- 4 Disposable bags and ties
- 1 Laminated instruction sheet

Deluxe kits contain the following items of personal protection equipment:

- 1 goggle, 1 suit, 2 pairs of overshoes, 2 pairs of gloves



◀ Chem Spill 35 & Chem Spill 35 Deluxe

Contents:

- 1 Bag
- 4 Chemical absorbent socks
- 25 Pads to soak up chemical
- 4 Disposable bags and ties
- 1 Laminated instruction sheet

Deluxe kits contain the following items of personal protection equipment:

- 1 goggle, 1 suit, 2 pairs of overshoes, 2 pairs of gloves

▼ ABX10 absorbent

ABX10 is a fire retardant, highly absorbent wood fibre which absorbs oil, grease and other liquid spillages. It is lightweight, non-toxic and can be incinerated, saving on costly landfill charges.

ABX10 is cost-effective against other granule absorbents.

- Fire retardant to BS476: Part 7 modified version
- Absorbs liquid quickly, soaking up dangerous hazards
- Easy to clean up, leaves no residue
- Can be used in a large variety of areas



- Environmentally friendly
- Comes complete with easy to use instructions
- No dust
- 30 litre bag
- Ideal for use in factories, laboratories or agricultural areas.



► ▼ Patchmac

Lay and repair Macadam. Patchmac is suitable for the repairing of drives and the construction of paths.



Points to note:

Tools can be easily cleaned with white spirit or with paraffin once the job is done.

DO: allow the surface to harden off and avoid manoeuvring cars over the surface for at least 24 hours.

DON'T: allow any sharp-cornered objects to come into contact with the surface until it has had time to set properly.

DON'T: try to use Patchmac when the air temperature is very low or if the base surface is very wet.

Health & Safety information:

Care must be taken when handling this material. Protective gloves should be worn, it is not intended for internal repair work.

Keep away from children.

Store in a cool place away from any food and always keep the bag sealed.

The material is flammable. Do not apply heat using a naked flame.

Good hygiene must always be observed. Any material on the skin should be removed as quickly as possible using a proprietary skin cleanser. Always wash thoroughly with soap and water.

If any material enters the eyes, or is accidentally swallowed, medical aid should be quickly sought. Avoid excessive breathing in of fumes. Ensure that there is adequate ventilation.



Buying the right amount:

One 25kg bag (or pail) of Patchmac covers about three-quarters of a square metre (about 8 sq ft) to a depth of about 20mm final thickness (i.e. after rolling and compaction). For a final thickness of 20mm you need to make a layer 25mm deep.

Surface preparation:

The surface to be covered with Patchmac must be firm and stable to provide a sound base. All loose material and vegetation (if any) should be carefully cleared away. Weedkiller is sometimes necessary to achieve a lasting result.

On some surfaces (e.g. broken paving, concrete or on a worn macadam surface) a coat of bitumen emulsion brushed on is advisable to provide good adhesion (at the rate of about ½ litre per square metre). Brush evenly in one direction only.

Laying Patchmac:

Before use it is best to leave bags in the sun for a few hours to help workability (or take them indoors overnight in colder weather). Empty the Patchmac from the bag where you need it and use a garden rake to spread a layer to the required thickness, remembering that 25mm raked = 20mm rolled.

Rolling and compaction:

Use the heaviest garden roller you can, wetting the roller wheel to prevent pick up.

Add extra material as desirable to achieve a completely level surface, re-rolling as necessary. Proper rolling is very important. Where space constraints limit the passage of a roller, obtain compaction by the use of a rammer; alternatively a heavy hammer plus hardwood block will produce a good result.

W

ith a highly knowledgeable sales team available to assist with any project at any stage from design through implementation and to completion, and access to a wide range of production facilities, we are committed to providing the complete supply service to our customers.

Based in Berkshire at the heart of the motorway network of the M4, M40 and M25, Street Furnishings Ltd is ideally placed for rapid dispatch of goods from its well stocked warehouse to all parts of the United Kingdom and Ireland - from the Channel Islands to the north of Scotland and from East Anglia to the west of Ireland.

Contact the sales office to speak to people who understand the needs of governmental and local authorities as well as contractors. Or visit the web site for more details of our extensive product range.

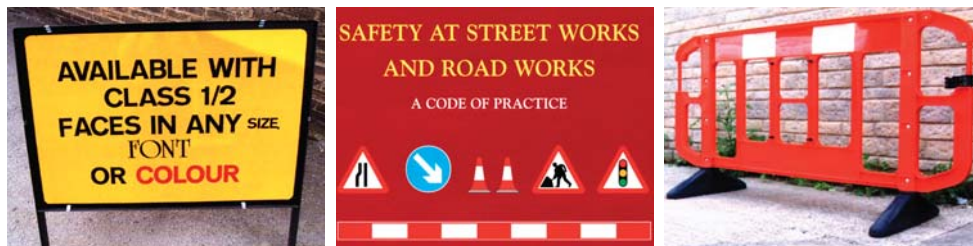

Festival House • Mumbery Hill • Wargrave • Berkshire • RG10 8EE
Tel: 01189 404717 • Fax: 01189 403216 • Email: mail@streetfurnishings.co.uk
www.streetfurnishings.co.uk

