

VSS LIMITED  
Sales@vssystem.com.uk  
0800 018 2324

# 884 MCT

## & 844 MPST

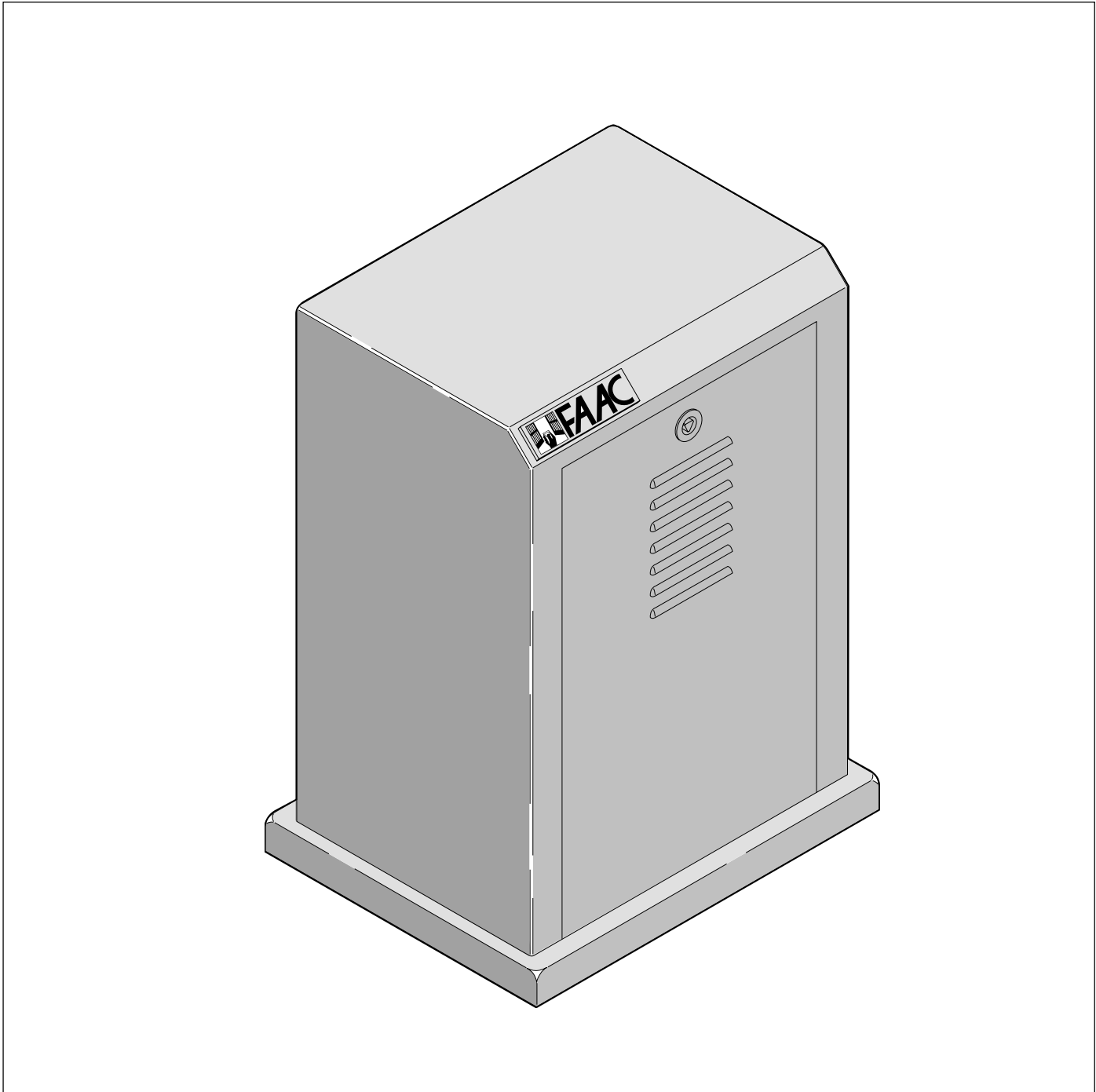

para la naturaleza  
100% papel reciclado

ist umweltfreundlich  
100% Altpapier

pour la nature  
papier recyclé 100%

for nature  
recycled paper 100%

per la natura  
carta riciclata 100%



# FAAC



UNI EN ISO 9001-085

Le descrizioni e le illustrazioni del presente manuale non sono impegnative. La FAAC si riserva il diritto, lasciando inalterate le caratteristiche essenziali dell'apparecchiatura, di apportare in qualunque momento e senza impegnarsi ad aggiornare la presente pubblicazione, le modifiche che essa ritiene convenienti per miglioramenti tecnici o per qualsiasi altra esigenza di carattere costruttivo o commerciale.

The descriptions and illustrations contained in the present manual are not binding. FAAC reserves the right, whilst leaving the main features of the equipments unaltered, to undertake any modifications it holds necessary for either technical or commercial reasons, at any time and without revising the present publication.

Les descriptions et les illustrations du présent manuel sont fournies à titre indicatif. FAAC se réserve le droit d'apporter à tout moment les modifications qu'elle jugera utiles sur ce produit tout en conservant les caractéristiques essentielles, sans devoir pour autant mettre à jour cette publication.

Die Beschreibungen und Abbildungen in vorliegendem Handbuch sind unverbindlich. FAAC behält sich das Recht vor, ohne die wesentlichen Eigenschaften dieses Gerätes zu verändern und ohne Verbindlichkeiten in Bezug auf die Neufassung der vorliegenden Anleitungen, technisch bzw. konstruktiv/kommerziell bedingte Verbesserungen vorzunehmen.

Las descripciones y las ilustraciones de este manual no comportan compromiso alguno. FAAC se reserva el derecho, dejando inmutadas las características esenciales de los aparatos, de aportar, en cualquier momento y sin comprometerse a poner al día la presente publicación, todas las modificaciones que considere oportunas para el perfeccionamiento técnico o para cualquier otro tipo de exigencia de carácter constructivo o comercial.

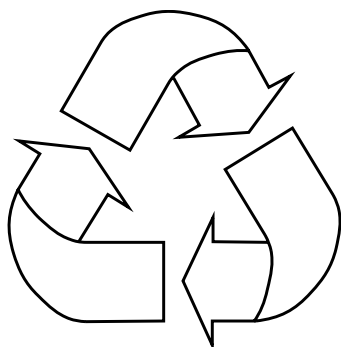

#### FAAC per la natura

- La presente istruzione è realizzata al 100% in carta riciclata.
- Non disperdete nell'ambiente gli imballaggi dei componenti dell'automazione bensì selezionate i vari materiali (es. cartone, polistirolo) secondo prescrizioni locali per lo smaltimento rifiuti e le norme vigenti.

#### FAAC for the environment

- The present manual is produced in 100% recycled paper
- Respect the environment. Dispose of each type of product packaging material (card, polystyrene) in accordance with the provisions for waste disposal as specified in the country of installation.

#### FAAC der Umwelt zuliebe

- Vorliegende Anleitungen sind auf 100% Altpapier gedruckt.
- Verpackungstoffe der Antriebskomponenten (z.B. Pappe, Styropor) nach den einschlägigen Normen der Abfallwirtschaft sortenrein sammeln.

#### FAAC écologique

- La présente notice a été réalisée 100% avec du papier recyclé.
- Ne pas jeter dans la nature les emballages des composants de l'automatisme, mais sélectionner les différents matériaux (ex.: carton, polystyrène) selon la législation locale pour l'élimination des déchets et les normes en vigueur.

#### FAAC por la naturaleza

- El presente manual de instrucciones se ha realizado, al 100%, en papel reciclado.
- Los materiales utilizados para el embalaje de las distintas partes del sistema automático (cartón, poliestireno) no deben tirarse al medio ambiente, sino seleccionarse conforme a las prescripciones locales y las normas vigentes para el desecho de residuos sólidos.



# FAAC

FAAC S.p.A.  
Via Benini, 1  
40069 Zola Predosa (BO) - ITALIA  
Tel.: 051/6172411 - Tlx.: 521087  
Fax: 051/758518

Timbro del Rivenditore:/Distributor's Stamp:/Timbre de l'Agent:/ Fachhändlerstempel:/Sello del Revendedor:



# EC MACHINE DIRECTIVE COMPLIANCE DECLARATION

(DIRECTIVE 89/392 EEC, APPENDIX II, PART B)

**Manufacturer:** FAAC S.p.A.

**Address:** Via Benini, 1  
40069 - Zola Predosa  
BOLOGNA - ITALY

**Hereby declares that:** the 884 MCT automation system

- is intended to be incorporated into machinery, or to be assembled with other machinery to constitute machinery in compliance with the requirements of Directive 89/392 EEC, and subsequent amendments 91/368 EEC, 93/44 EEC and 93/68 EEC;
- complies with the essential safety requirements in the following EEC Directives:  
  
73/23 EEC and subsequent amendment 93/68 EEC.  
89/336 EEC and subsequent amendments 92/31 EEC and 93/68 EEC.

and furthermore declares that unit must not be put into service until the machinery into which it is incorporated or of which it is a component has been identified and declared to be in conformity with the provisions of Directive 89/392 EEC and subsequent amendments enacted by the national implementing legislation.

Bologna, 1 January 1997

Managing  
Director  
A. Bassi

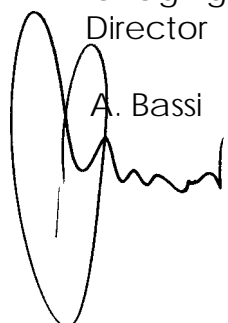

## IMPORTANT NOTICE FOR THE INSTALLER

### GENERAL SAFETY REGULATIONS

- 1) **WARNING! FAAC strongly recommends to follow these instructions literally for the safety of persons. Improper installation or misuse of the product will cause very serious damages to persons.**
- 2) Read the instructions carefully before installing the product.
- 3) Packaging material (plastic, polystyrene etc.) is a potential hazard and must be kept out of reach of children.
- 4) Keep these instructions for future reference.
- 5) This product has been designed and manufactured only for the use stated in this manual. Any other use not expressly set forth will affect the reliability of the product and/or could be source of hazard.
- 6) FAAC S.p.A. cannot be held responsible for any damage caused by improper use or different from the use for which the automation system is destined to.
- 7) Do not use this device in areas subject to explosion: the presence of flammable gas or fumes is a serious hazard.
- 8) Mechanical constructive elements must comply with UNI8612, CEN pr EN 12604 and CEN pr EN 12605 standards. Countries outside the EC shall follow the regulations above besides their national normative references in order to offer the utmost safety.
- 9) FAAC cannot be held responsible for failure to observe technical standards in the construction of gates and doors, or for any deformation of the gates which may occur during use.
- 10) Installation must comply with UNI8612, CEN pr EN 12453 and CEN pr EN 12635. The degree of safety of the automation must be C+E.
- 11) Before carrying out any operations, turn off the system's main switch.
- 12) An omnipower switch shall be provided for the installation with an opening distance of the contacts of 3 mm or more. Alternatively, use a 6A thermomagnetic breaker with multi-pole switching.
- 13) Ensure that there is a differential switch up-line of the electrical system, with a trip threshold of 0.03A.
- 14) Check that the earthing plant is in perfect condition and connect it to the metallic parts. Also earth the yellow/green wire of the operator.
- 15) The safety devices (e.g. photocells, safety edges, etc.) protect areas wherethere is a **mechanical movement hazard**, e.g. crushing, entrapment and shearing.
- 16) Each installation must be fitted with at least one flashing light (e.g. FAAC LAMP, MINILAMP etc.) as well as a warning plate suitably fixed to the gate, besides the safety devices as per point 16. above.
- 17) FAAC cannot be held responsible regarding safety and correct functioning of the automation in the event that parts other than FAAC original parts are used.
- 18) Use only FAAC original spare parts for maintenance operations.
- 19) Do not carry out any modifications to automation components.
- 20) The installer must supply all information regarding manual operation of the system in the event of an emergency and provide the end-user with the "End-user Guide" attached to the product.
- 21) Keep out of persons when the product is in operation.
- 22) Keep out of reach of children the remote radio controls and any control devices. The automation could be operated unintentionally.
- 23) The end-user must avoid any attempt to repair or adjust the automation personally. These operations must be carried out exclusively by qualified personnel.
- 24) **What is not explicitly stated in these instructions is not permitted.**

# AUTOMATION 884 & 844 MPST

These instructions apply to the following models: **884 MCT**  
 The FAAC model 884 automations for sliding gates are electromechanical operators which transmit movement to the leaf by means of a pinion with rack coupled in an appropriate manner to the sliding gate.

By using a self-braking motor the system is guaranteed to be mechanically locked when the motor is not in operation so a lock does not need to be installed. The gear motors have adjustable mechanical clutches to ensure correct use of the automation. A convenient manual release device allows the gate to be opened in the event of a power failure or malfunction. The electronic control unit is incorporated in the gear motors.

The 884 automations have been designed and built for vehicle access control in industrial areas. Do not use for any other purpose.

## 1. DESCRIPTION AND TECHNICAL SPECIFICATIONS

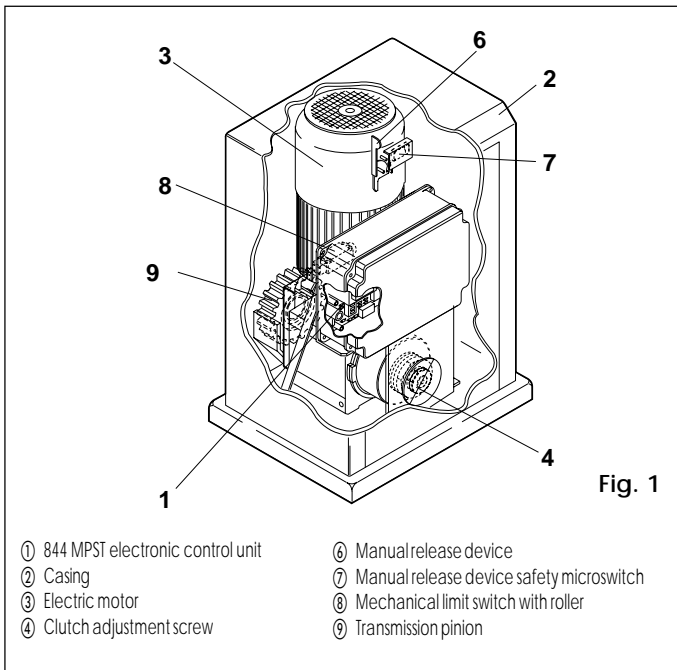

## 2. DIMENSIONS

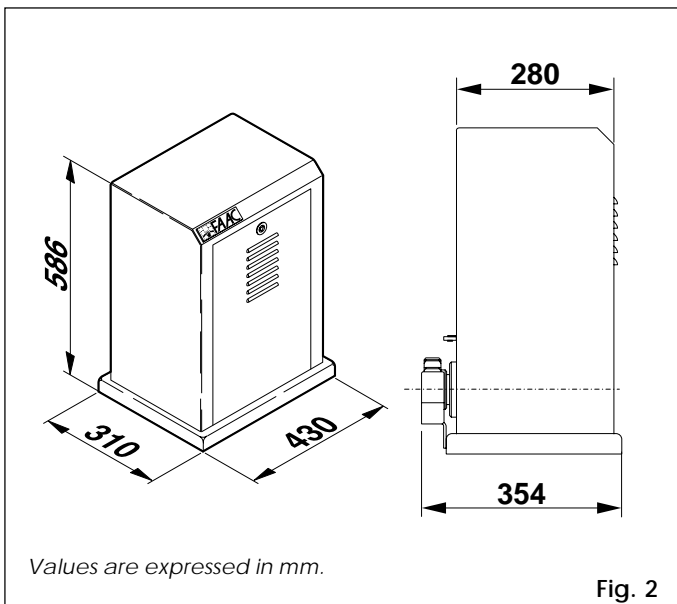
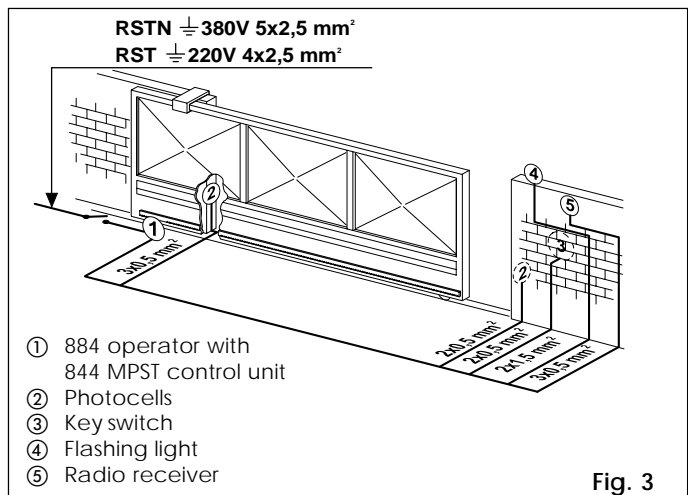

Table 1 Technical specifications

|                                  |   |
|----------------------------------|---|
| Power supply                     | 230V 3ph / 400V 3ph + N (+ 6 % - 10 %) 50Hz |
| Power consumption (W)            | 850   |
| Reduction ratio                  | 1 : 43.2                                    |
| No. of pinion teeth CR           | Z 16 - Rack 30x30 Module 6                  |
| Nominal torque Nm                | 155   |
| Max. thrust N                    | 5000  |
| Duty rating                      | 50% / 100% (2000 Kg)                        |
| Oil quantity (kg)                | 2   |
| Temperature range                | - 20 ÷ + 55 °C                              |
| Gear motor weight (kg)           | 50  |
| Housing protection               | IP 55                                       |
| Max. gate weight (kg)            | 3500  |
| Gate speed                       | 10 m/min                                    |
| Max. gate length                 | 35 m  |
| Clutch                           | Twin discs in oil bath                      |
| Housing treatment                | cataphoresis                                |
| Casing painting                  | polyester RAL 2004                          |
| Control unit                     | 844 MPST (incorporated)                     |
| Limit switches                   | mechanical                                  |
| Gear motor dimensions LxHxD (mm) | see Fig. 2                                  |

| Electric motor technical specifications |   |
|---|---|
| Power supply                            | 230V (+ 6 % - 10 %) / 400V (+ 6 % - 10 %) |
| Frequency Hz                            | 50  |
| Current A                               | 2.7 / 1.6                                 |
| Power consumption kW                    | 0.8                                       |
| Motor speed rpm                         | 1400                                      |

## 3. ELECTRICAL SET-UP



## 4. INSTALLING THE AUTOMATION

### 4.1. PRELIMINARY CHECKS

For safe, correct operation of the automation, make sure that the following requirements are met:

- The gate's structure must be suitable for automation. Take special care to ensure that the wheels are large enough to support the full weight of the gate, that a top runner is installed and that mechanical limit stops are fitted to prevent the gate from coming off the runner.
- The characteristics of the ground must ensure sufficient support for the foundation plinth.
- There must be no pipes or electrical cables in the area to be dug for installing the foundation plinth.

- If the gear motor is located in a vehicle transit area, it is a good idea to provide protection against accidental collisions.
- Check that the gear motor has an efficient earth connection.

**4.2. INSTALLING THE BASE PLATE**

- 1) The base plate must be positioned as shown in Fig. 4. For the positioning distances refer to fig. 5.

**Important:** The plate must be level with the middle of the pinion. Remember to maintain a minimum distance of 10 mm between the rack and the gate.

- 2) Assemble the foundation plate as shown in A, Fig. 4.
- 3) Prepare a foundation plinth as shown in Fig. 4 and install the base plate providing one or more conduits for electrical cables. Use a level to check that the plate is perfectly horizontal and wait for the cement to set.

**N.B.:** It is advisable to install the plate slightly raised from the ground. See A, fig. 9.

- 4) Set up the electrical cables for connection to the accessories and the electricity supply as described in section 5. For ease of connection, ensure that the cables protrude by about 1 m from the hole in the base plate.

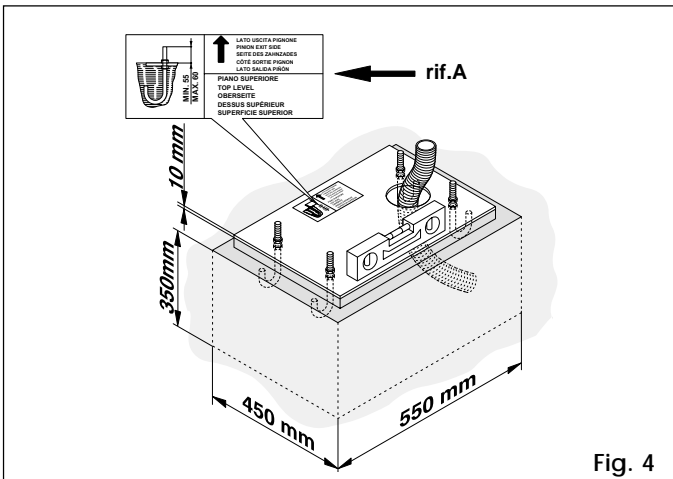

Fig. 4

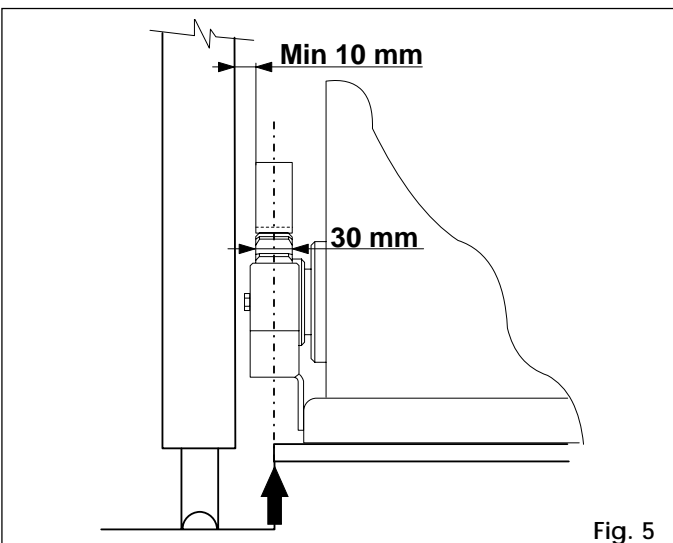

Fig. 5

**4.3. MOUNTING THE PINION**

Before mounting the operator on the foundation plate, mount the pinion on the transmission shaft and fit the casing provided as shown in fig. 6.

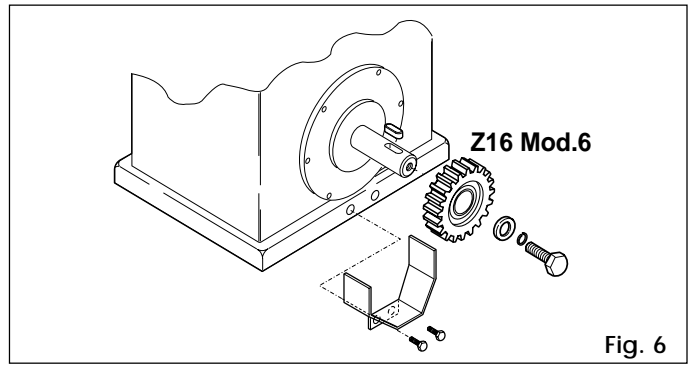

Fig. 6

**4.4. MECHANICAL INSTALLATION**

- 1) Remove the casing (2, fig. 1) and position the gear motor on the foundation plate. Fit, but do not tighten, the washer, the split washer and the nut as shown in fig. 7-9.

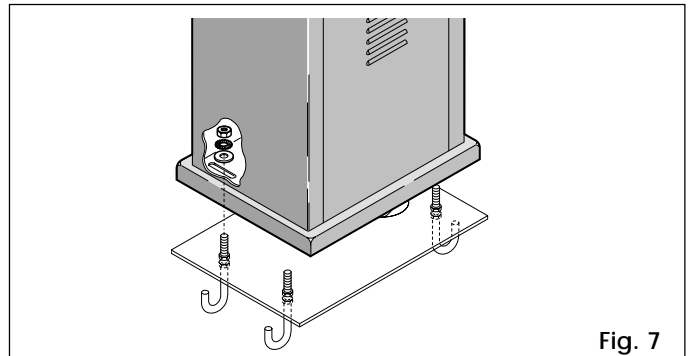

Fig. 7

- 2) Fit the adjustment screws on the gear motor base as shown in A, fig. 8.
- 3) Adjust the height of the feet while keeping the gear motor raised from the plate by 1 cm and maintaining the distance from the gate shown in figs. 5 and 9.
- 4) Use a level to check that the operator is perfectly horizontal.
- 5) Tighten up the four securing nuts provisionally.
- 6) Set up the operator for manual operation as described in section 12.

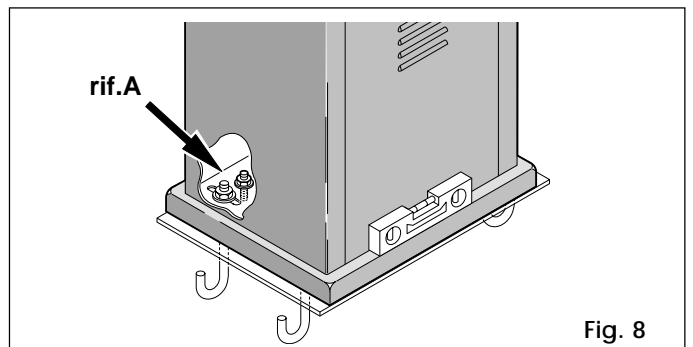

Fig. 8

**4.5 PREPARING FOR RACK MOUNTING**

**Important:** To mount the rack on the leaf it is necessary to construct special supports specifically for the type of gate. Fig. 10 shows an example of "L" support. For positioning the supports refer to figs. 5 and 9.

**4.5.1 MOUNTING THE RACK**

- 1) Slide the leaf manually to the closed position.
- 2) Rest the first rack element level on the pinion and weld the support onto the gate as shown in fig. 11.
- 3) Move the gate manually making sure that the rack rests on the pinion and weld the remaining supports.

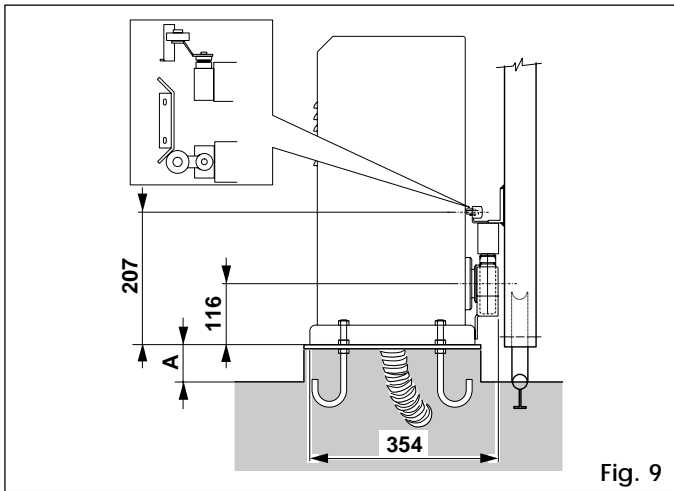

Fig. 9

4) Place another rack element next to the first and use a section of rack to set the teeth of the two elements in phase as shown in 11A.

5) Open the gate manually and weld the remaining supports. Proceed in this manner for all the rack elements and supports until the entire gate has been covered.

**N.B.:** Check that none of the rack elements come off the pinion during the movement of the gate.

**Important:** Do not weld the rack elements together.

After installing the rack, lower the position of the gear motor (fig. 12) by adjusting the level screws (A, Fig. 8) by about 4 mm to ensure correct meshing with the pinion.

Screw up tightly the 4 gear motor securing nuts.

**Check manually that the gate reaches the mechanical travel limits correctly and that it does not encounter friction during its travel.**

**Do not use grease or other lubricants between the pinion and the rack.**

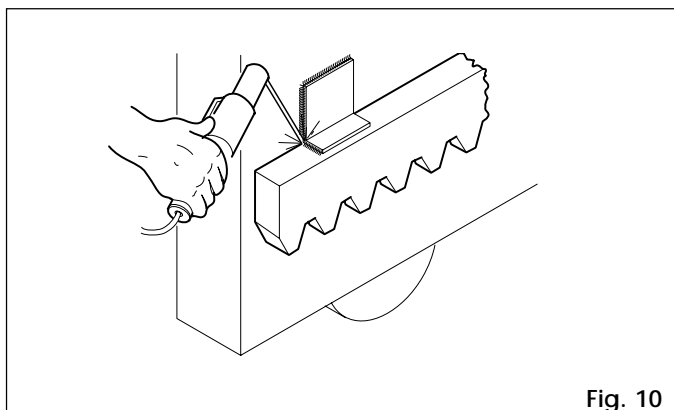

Fig. 10

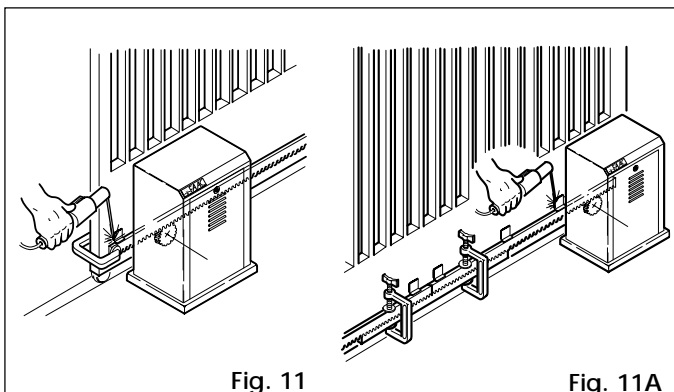

Fig. 11

Fig. 11A

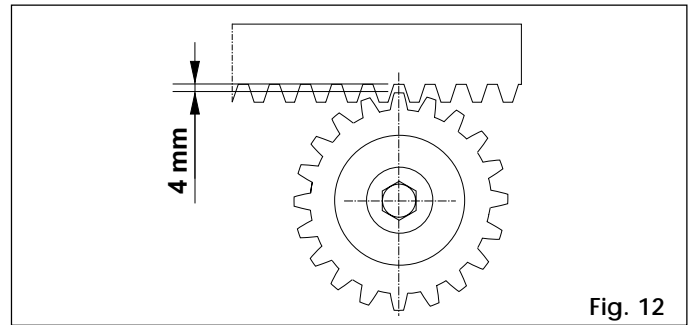

Fig. 12

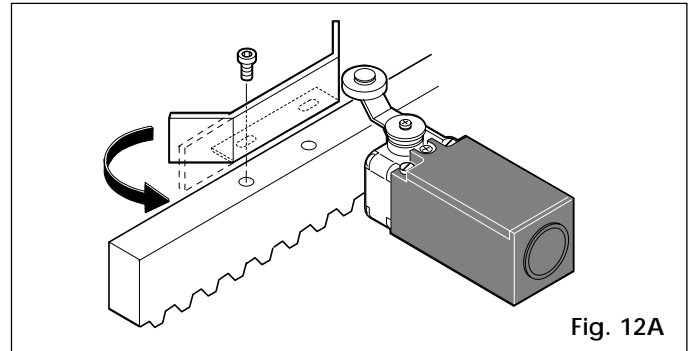

Fig. 12A

**4.5.2. POSITIONING THE BENT TRAVEL STOP PLATES**

The 884 operator is equipped with a mechanical travel stop with roller and trigger. The movement of the gate is stopped when a bent travel stop plate fixed to the top of the rack operates the trigger, tripping the microswitch (fig. 12A).

To position the two travel stop plates provided, proceed as follows:

- 1) Switch on the power supply.
- 2) Move the gate by hand towards its open position, stopping 5 cm from the desired closure position.
- 3) Slide the travel stop plate along the rack in the opening direction.

When the LED of the opening travel end limit switch (FCA) in the 844 MPST electronic control unit (fig. 16) goes out, advance the travel stop plate 10 mm more, and fasten it temporarily in position with two spot welds

- 4) Move the gate by hand towards its closed position, stopping 5 cm from the mechanical travel stop.
- 5) Slide the travel stop plate along the rack in the closing direction.

When the LED of the closing travel end limit switch (FCC) in the 844 MPST electronic control unit (fig. 16) goes out, advance the travel stop plate 10 mm more, and fasten it temporarily in position with two spot welds.

**Note:** the travel stop plates may be fastened by means of screws, if desired (fig. 12a).

The fastening slot makes it possible, if necessary, to adjust the travel stop position.

**Important:** a) The limit switch must be tripped by the initial bent part of the travel stop plate, as shown in fig. 12A.

b) It is advisable to straighten the final bent part of the travel stop plate, as shown in fig. 12A, in order to prevent the plate from passing the limit switch.

6) Lock the system (see paragraph 12).

**Caution:** To prevent damage to the operator and/or stoppage of operation, leave about 5 cm between the limit switch position and the desired closure position.

5. START-UP

5.1. CONNECTION TO ELECTRONIC CONTROL UNIT

**Warning:** Always turn off the electricity supply before carrying out any work on the electronic control unit (connections, programming, maintenance).

Observe points 10, 11, 12, 13 and 14 in the GENERAL SAFETY INSTRUCTIONS.

Since the system requires two different power supplies (230 and 400 Vac), install two differential magneto-thermal circuit breakers with adequate trip threshold up-line of the system.

Connect the earth cable to the connection on the base of the operator. See fig. 15.

The gearmotor is provided with a safety device (Fig.1 Ref. 7) operated by the relay system.

While activated the safety device keeps the gearmotor from making any movement.

As shown in Fig. 3, prepare the conduits and make the electrical connections from the 844MPST electronic control unit to the chosen accessories.

Always route the power supply cables separately from the control and safety cables (keyswitch, receiver, photocells, etc.). Use separate conduits to avoid any interference.

Table 2 Technical specifications 844MPST

|                         |  |
|-------------------------|--|
| Power supply            | 230 V (+6% - 10%) 50 Hz  |
| Absorbed power          | 10W  |
| Max. motor load         | 800W   |
| Max. electric lock load | 0.5A   |
| Temperature range       | -20 °C +55 °C  |
| Fuses                   | 3 (see fig. 5.1.1)   |
| Operation logics        | Automatic / Semiautomatic / Safety / Semiautomatic B / Deadman C                                     |
| Pause time              | Adjustable by dip-switches   |
| Terminal block inputs   | Open / Partial opening-Close<br>Stop / Closing safeties / Power supply                               |
| Terminal block outputs  | Flashing light - motors -<br>24 Vdc accessories power supply -<br>24 Vdc warning lamp power supply - |
| Quick connector         | Decoder cards / RP-SL-DS   |
| Programmable functions  | Operating logics / Pause times / Warning lamp operation  |

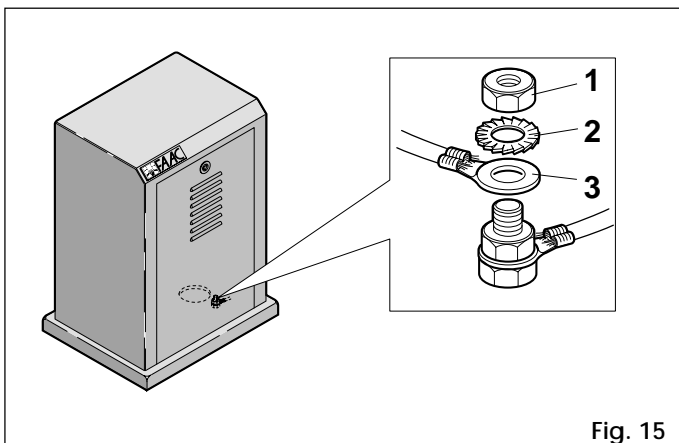

Fig. 15

5.1.1. LAYOUT AND ELECTRICAL CONNECTIONS

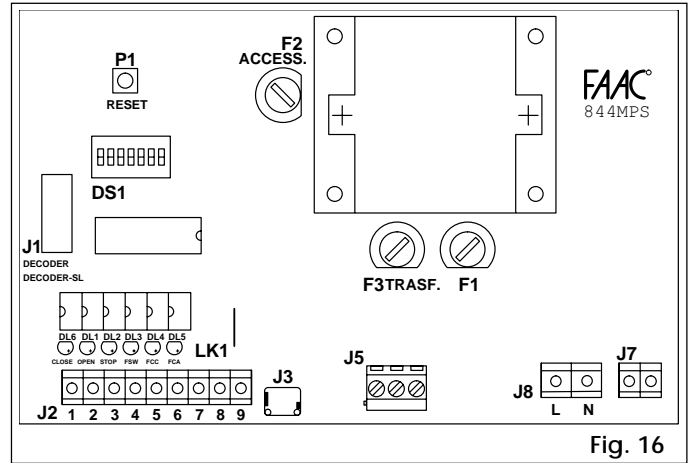

Fig. 16

Table 3 Control unit components 844MPST

|     |                                     |
|-----|-------------------------------------|
| LD1 | OPEN LED                            |
| LD2 | STOP LED                            |
| LD3 | SAFETY LED                          |
| LD4 | CLOSURE LIMIT SWITCH LED            |
| LD5 | OPENING LIMIT SWITCH LED            |
| LD6 | LED OPEN PARTIAL / CLOSE            |
| P1  | RESET BUTTON                        |
| J1  | DECODER CONNECTOR                   |
| J2  | LOW VOLTAGE TERMINAL BLOCK          |
| J3  | LIMIT SWITCH CONNECTOR              |
| J5  | CONTACTOR CONNECTION TERMINAL BLOCK |
| J7  | FAAC LAMP CONNECTION TERMINAL BLOCK |
| J8  | POWER SUPPLY                        |
| F1  | CONTACTOR FUSE (F5 A)               |
| F2  | ACCESSORIES FUSE (T 1.6 A)          |
| F3  | TRANSFORMER FUSE (T250 mA)          |
| LK1 | WARNING LAMP FREE CONTACT           |
| DS1 | PROGRAMMING DIPSWITCH               |

5.1.2 HIGH VOLTAGE ELECTRICAL CONNECTIONS

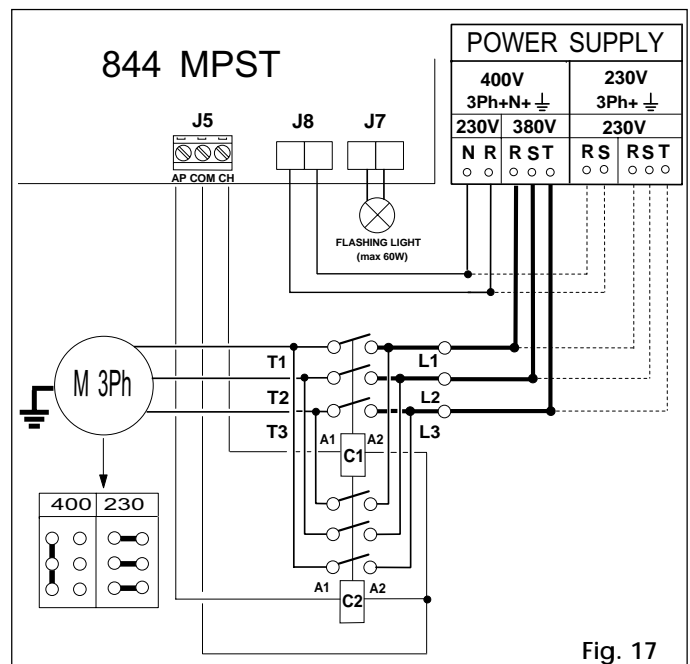

Fig. 17



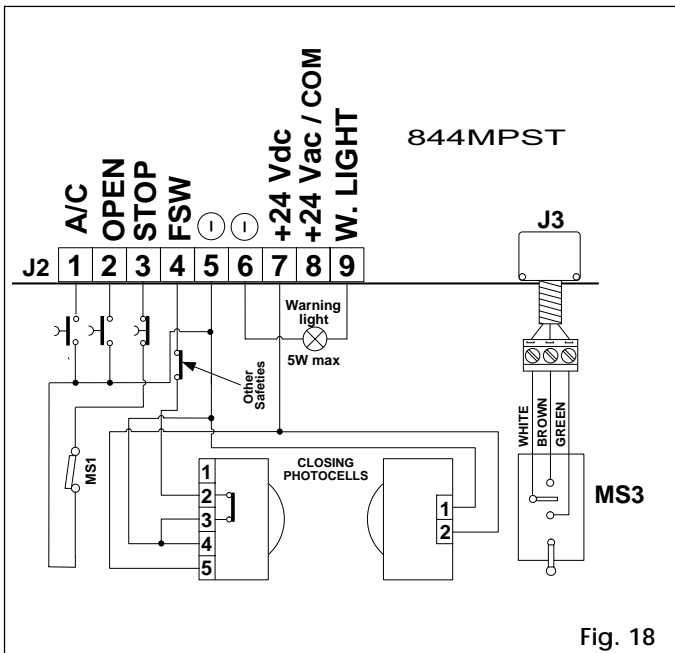

Fig. 18

Tab. 4 Accessories current draw

| TYPE OF ACCESSORY | NOMINAL CURRENT DRAW |
|-------------------|----------------------|
| PLUS 40SL         | 30mA                 |
| PLUS E            | 20mA                 |
| MINIDEC SL / DS   | 6mA                  |
| DECODER SL/DS     | 20mA / 55mA          |
| RP ESL / EDS      | 12mA / 6mA           |
| DIGICARD          | 15mA                 |
| METALDIGIKEY      | 15mA                 |
| FOTOSWITCH        | 90mA                 |
| DETECTOR F4 / PS6 | 50mA                 |
| PHOTOBEAM         | 50mA                 |

**W.LIGHT (terminals 6 - 8 - 9)**

These are the 24 Vdc terminals to which the warning lamp must be connected. With jumper LK1 intact it is possible to power a 24V / 5W max. warning lamp between terminals 6 and 9. In case a potential free contact is needed between the terminal strips 8 and 9, the link LK1 must be cut. (see Table 5).

**WARNING:** If the jumper LK1 is broken, the 24 Vac accessories power supply (terminals 6 and 8) is no longer available.

Table 5: Warning lamp connection

| LK1 INTACT | LK1 BROKEN (FREE CONTACT) |
|------------|---------------------------|
| ●—●        | ●—X—●                     |

① **Low voltage terminal block J2** (Fig. 16) is used to connect all accessories (see Table 4).

**1. A/C Partial opening**

This means any control device with a N.O. contact which causes partial opening of the gate when activated in E1, E2, A1, A2, S1 or S2 logics. In B and C logics it causes the gate to close. To install more than one partial opening control device, connect the N.O. contacts in parallel.

**2. OPEN**

This means any control device with a N.O. contact which causes the gate to open when activated. In automatic and semiautomatic logics it is active for both opening and closure. To install more than one opening control device, connect the N.O. contacts in parallel.

**3. STOP**

This means a control device with a N.C. contact which causes the gate status (opening-pause-closure) to be interrupted until the next impulse is sent. To install more than one stop device, connect the N.C. contacts in series to MS1 and MS2.

**4. FSW SAFETIES**

This means all devices (photocells, safety edges, magnetic loops) with a N.C. contact which stop the movement of the gate when an obstacle is present in the area protected by the safety devices. To install more than one safety device, connect the N.C. contacts in series.

**N.B.:** if safety devices are not connected, jumper terminals 4 and 5 on the electronic control unit.

**5. Controls common and accessories power supply negative**

**6. 24 Vac output for warning lamp power supply**

**7. +24 Vdc accessories power supply positive**

**Warning:** the maximum load of the accessories is 500mA. To calculate power consumption refer to the corresponding table.

② **Connector J3** limit switch unit connection

③ **Terminal block J5** contactor connection

The motor control contactors must be connected to these terminals.

④ **Terminal block J6 (fig. 16)**

L: 230V power supply (live)

N: 230V power supply (neutral)

⑤ **Terminal block J7 (fig. 16)**

Flashing light output (230V)

**6. BEHAVIOUR OF SAFETY DEVICES**

The safety devices operate during closure only. In "A1", "E1" and "S1" logics, interrupting the safety device contacts causes the gate to stop closing and start opening immediately. In "A2", "E2" and "S2" logics, interrupting the safety device contacts causes the gate to stop closing, then to start opening again when the safety devices are released.

In "B" and "C" logics, interrupting the safety device contacts causes the gate to stop closing.

**7. DIPSWITCH SETTINGS**

To program automation operation, set the dipswitches as shown in the diagram below.

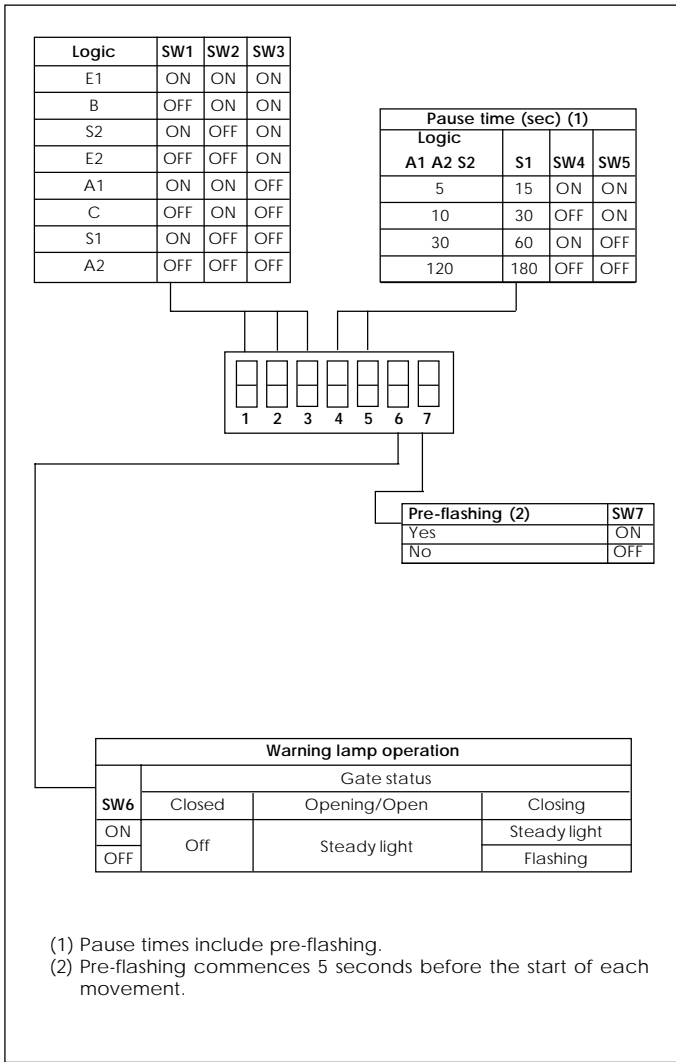

N.B.: PRESS THE RESET BUTTON AFTER ALL PROGRAMMING OPERATIONS.

**8. OPERATION IN VARIOUS LOGICS**

The following 8 logics are available:

E1/E2/B: "Semiautomatic"      A1/A2: "Automatic"  
 S1/S2: "Safety"                      C: "Deadman"

Operation of the various logics is shown in tables 6-7-8-9-10-11-12-13.

**TABLE 6 LOGIC E1 (SEMI-AUTOMATIC)**

| LOGIC E1    | IMPULSES   |           |                |
|-------------|--|-----------|----------------|
| GATE STATUS | OPEN - A/C (1) -                                       | STOP      | SAFETY         |
| CLOSED      | opens (2)  | no effect | no effect      |
| OPEN        | recloses (2)   | no effect | no effect      |
| CLOSING     | inverts motion   | stops     | inverts motion |
| OPENING     | stops  | stops     | no effect      |
| STOPPED     | recloses (reopens when safety devices are engaged) (2) | no effect | no effect      |

**TABLE 7 LOGIC E2 (SEMI-AUTOMATIC)**

| LOGIC E2    | IMPULSES   |                |                                   |
|-------------|--|----------------|-----------------------------------|
| GATE STATUS | OPEN - A/C(1)-   | STOP           | SAFETY                            |
| CLOSED      | opens (2)  | no effect      | no effect                         |
| OPEN        | recloses (2)   | stops counting | no effect                         |
| CLOSING     | inverts motion   | stops          | freezes pause until disengagement |
| OPENING     | stops  | stops          | no effect                         |
| STOPPED     | recloses (reopens when safety devices are engaged) (2) | no effect      | no effect                         |

**TABLE 8 LOGIC A1 (AUTOMATIC)**

| LOGIC A1    | IMPULSES                                |                |                                   |
|-------------|---|----------------|-----------------------------------|
| GATE STATUS | OPEN - A/C (1) -                        | STOP           | SAFETY                            |
| CLOSED      | opens and recloses after pause time (2) | no effect      | no effect                         |
| OPEN        | recloses after 5 s (3)                  | stops counting | freezes pause until disengagement |
| CLOSING     | inverts motion                          | stops          | no effect                         |
| OPENING     | no effect                               | stops          | no effect                         |
| STOPPED     | recloses (2)                            | no effect      | no effect                         |

**TABLE 9 LOGIC A2 (AUTOMATIC)**

| LOGIC A2    | IMPULSES                                |                |                                    |
|-------------|---|----------------|------------------------------------|
| GATE STATUS | OPEN - A/C (1) -                        | STOP           | SAFETY                             |
| CLOSED      | opens and recloses after pause time (2) | no effect      | no effect                          |
| OPEN        | recloses after 5 s (3)                  | stops counting | recloses after 5 s when disengaged |
| CLOSING     | inverts motion                          | stops          | inverts motion                     |
| OPENING     | no effect                               | stops          | no effect                          |
| STOPPED     | recloses (2)                            | no effect      | no effect                          |

**TABLE 10 LOGIC S1 (SAFETY)**

| LOGIC S1    | IMPULSES                                |                |                                    |
|-------------|---|----------------|------------------------------------|
| GATE STATUS | OPEN - A/C (1) -                        | STOP           | SAFETY                             |
| CLOSED      | opens and recloses after pause time (2) | no effect      | no effect                          |
| OPEN        | recloses immediately (2 and 3)          | stops counting | recloses after 5 s when disengaged |
| CLOSING     | inverts motion                          | stops          | inverts motion                     |
| OPENING     | inverts motion                          | stops          | no effect                          |
| STOPPED     | recloses (2)                            | no effect      | no effect                          |

**TABLE 11 LOGIC S2 (SAFETY)**

| LOGIC S2    | IMPULSES                                |                |  |
|-------------|---|----------------|--|
| GATE STATUS | OPEN - A/C (1) -                        | STOP           | SAFETY                                       |
| CLOSED      | opens and recloses after pause time (2) | no effect      | no effect                                    |
| OPEN        | recloses immediately (2 and 3)          | stops counting | freezes pause until disengagement            |
| CLOSING     | inverts motion                          | stops          | stops and inverts motion when disengaged (2) |
| OPENING     | inverts motion                          | stops          | no effect                                    |
| STOPPED     | recloses (2)                            | no effect      | no effect                                    |

**TABLE 12 LOGIC B (SEMI-AUTOMATIC)**

| LOGIC B     | IMPULSES              |                       |                              |                |
|-------------|-----------------------|-----------------------|------------------------------|----------------|
| GATE STATUS | OPEN                  | A/C (5)               | SAFETY (until disengagement) | STOP           |
| CLOSED      | opens (2)             | no effect             | no effect                    | no effect      |
| OPEN        | no effect             | closes (2)            | inhibits closing             | no effect      |
| CLOSING     | no effect             | no effect             | stops                        | stops movement |
| OPENING     | no effect             | no effect             | no effect                    | stops movement |
| STOPPED     | completes opening (2) | completes closing (2) | inhibits closing             | no effect      |

**TABLE 13 LOGIC C (DEADMAN)**

| LOGIC C     | IMPULSES          |                   |                              |           |
|-------------|-------------------|-------------------|------------------------------|-----------|
| GATE STATUS | OPEN (4)          | A/C (4 and 5)     | SAFETY (until disengagement) | STOP      |
| CLOSED      | opens             | no effect         | no effect                    | no effect |
| OPEN        | no effect         | closes            | inhibits closing             | no effect |
| CLOSING     | no effect         | no effect         | stops                        | stops     |
| OPENING     | no effect         | no effect         | no effect                    | stops     |
| STOPPED     | completes opening | completes closing | inhibits closing             | no effect |

- (1) The A/C input enables partial opening.
- (2) With pre-flashing selected movement starts after 5 seconds.
- (3) If the impulse is sent after pre-flashing the timer recounts.
- (4) For operation in C logic keep the pushbutton depressed. Movement stops upon release.
- (5) The A/C input controls closure.

## 9. CHECKING DIRECTION OF ROTATION

1 - Check the status of LEDs 4 and 5 with reference to Table 14.

**Table 14 Operation of status signalling LEDs**

| LEDS                  | ON                        | OFF                          |
|-----------------------|---------------------------|------------------------------|
| OPEN input A          | Command active            | Command inactive             |
| OPEN input B          | Command active            | Command inactive             |
| STOP                  | Command inactive          | Command activated            |
| FSW (Open safeties)   | Safeties disengaged       | Safeties engaged             |
| FCA (Open limit sw.)  | Opening limit switch free | Opening limit switch engaged |
| FCC (Close limit sw.) | Closure limit switch free | Closure limit switch engaged |

**N.B.:** The condition of the LEDs with the gate at rest is shown in bold type.

If the Open/Closed positions do not correspond to the status of the LEDs, invert the brown and green MS3 wires on the terminal block (See Fig. 18).

2 - Disconnect the power supply from the electronic control unit and release the operator.

- Slide the gate manually to the mid-travel position.
- Re-engage the operator and restore the electrical power supply.
- Send an OPEN impulse and check that the gate opens.

If the first impulse causes the gate to close, invert 2 phases of the motor power supply.

## 10. SETTING THE MECHANICAL CLUTCH

To calibrate the transmitted torque adjustment system, refer to fig. 19.

Remove the safety lid and the lock nut. Adjust the clutch using a socket wrench (fig. 19).

Turn the nut clockwise to increase torque.

Turn the nut anticlockwise to decrease torque.

Activate the operator and check that the clutch is set to allow the leaf to slide without being too dangerous.

Refit the lock nut and the safety lid.

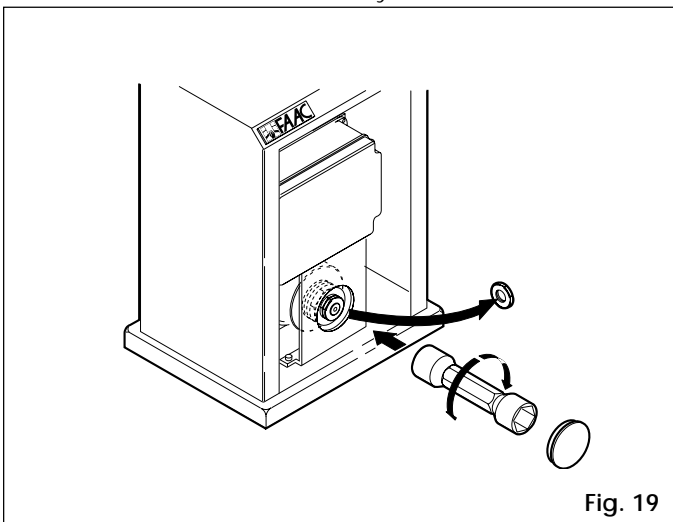

Fig. 19

## 11. TESTING THE AUTOMATION

When installation is complete, affix the danger warning label to the top of the casing (Fig. 20). Thoroughly check operation of the automation and all connected accessories.

Give the customer the User's Guide. Explain correct use and

operation of the gear motor and draw attention to the potential danger zones of the automation.

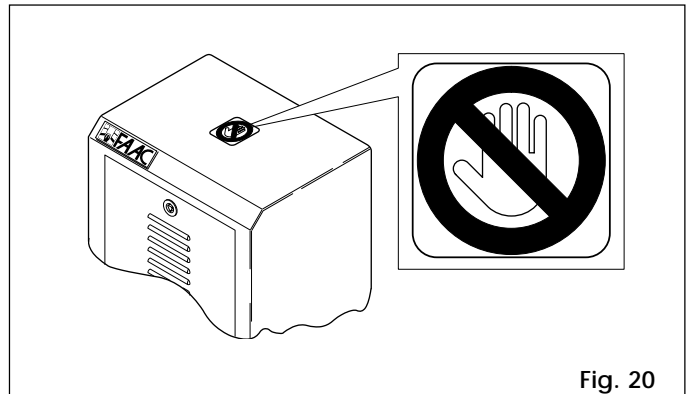

Fig. 20

## 12. MANUAL OPERATION

If the gate has to be operated manually due to a power failure or malfunction of the automation, use the release device as follows.

- Open the door in the casing using the triangular key provided (see fig. 21).

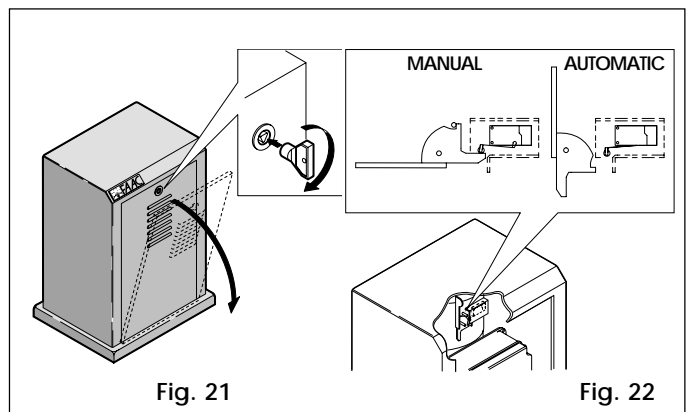

Fig. 21

Fig. 22

- Operate the release lever shown in fig. 22 (pos. MANUAL).
- A safety microswitch in the release system prevents the automation from being activated by accidental commands (7, fig. 1).
- Close the door and open or close the gate manually.

## 13. RETURN TO NORMAL OPERATION

- Open the door in the casing using the triangular key provided (see fig. 21).
- Move back the lever shown in fig. 22 up to the mechanical stop (pos. AUTOMATIC).
- Close the door.

## 14. MAINTENANCE

When performing maintenance always check that the anti-crushing clutch is correctly regulated and that the safety devices operate correctly.

## 15. REPAIRS

For repairs contact an authorised FAAC Repair Centre.

## USER'S GUIDE

### AUTOMATION 884

Read the instructions carefully before using the product and keep them for future reference.

#### GENERAL SAFETY INSTRUCTIONS

If correctly installed and operated, the 884 automations ensure a high level of safety.

However, some simple rules should be followed to avoid accidents:

- Do not stand in the vicinity of the automation or allow anyone else, especially children, to do so and do not place objects in the vicinity of the automation. This is particularly important during operation.
- Keep remote controls and other control devices out of the reach of children to prevent them from accidentally operating the automation.
- Do not allow children to play with the automation.
- Do not deliberately obstruct the movement of the gate.
- Make sure that branches or bushes do not interfere with the movement of the gate.
- Keep the luminous signalling systems efficient and clearly visible.
- Do not attempt to operate the gate manually without first releasing it.
- In the event of a malfunction, release the gate to allow access and call a qualified technician for service.
- After setting manual operation, disconnect the electricity supply from the system before returning to normal operation.
- Do not make any modifications to components belonging to the automation system.
- Do not attempt to perform any repair work or tamper with the automation. Call FAAC qualified personnel for repairs.
- At least once every six months have the automation, the safety devices and the earth connection checked by a qualified technician.

#### DESCRIPTION

The FAAC 884 automation is ideal for controlling industrial vehicle access areas.

The 884 for sliding gates is an electromechanical operator which transmits movement to the leaf by means of a pinion with rack or chain coupled in an appropriate manner to the sliding gate.

If automatic operation has been selected, sending an impulse causes the gate to reclose on its own after the selected pause time.

If semiautomatic operation has been selected, a second impulse must be sent to reclose the gate.

An opening impulse sent while the gate is reclosing causes it to change direction of movement.

A stop command (if available) stops movement at any time. For detailed information on operation of the sliding gate in the various operating modes, contact the installation technician.

The automations have safety devices (photocells) which prevent the gate from reclosing when an obstacle lies within the area they are protecting.

The system ensures mechanical locking when the motor is not in operation, so it is not necessary to install a lock.

The gear motors have an adjustable mechanical clutch for safe use of the automation.

The electronic control unit is incorporated in the gear motor.

A convenient manual release device allows the gate to be

operated in the event of a power failure or malfunction. The light flashes while the gate is moving.

#### MANUAL OPERATION

If the gate has to be operated manually due to a power failure or malfunction of the automation, use the release device as follows:

- Open the door in the casing using the triangular key provided (see Fig. 1).
- Operate the release lever shown in fig. 2 (pos. MANUAL).
- A safety microswitch in the release system prevents the automation from being activated by accidental commands.
- Close the door and open or close the gate manually.

#### RETURN TO NORMAL OPERATION

- Open the door in the casing using the triangular key provided (see Fig. 1).
- Move back the lever shown in fig. 2 up to the mechanical stop (pos. AUTOMATIC).
- Close the door.

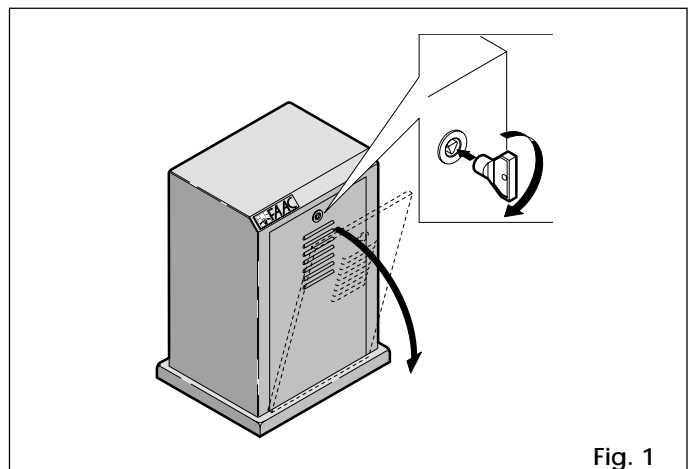

Fig. 1

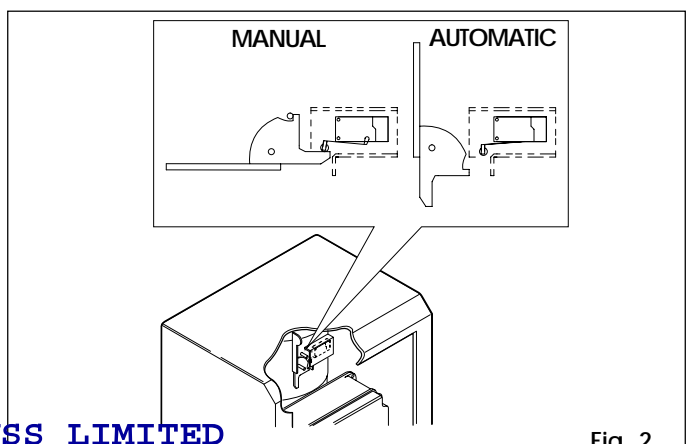

Fig. 2

VSS LIMITED

[Sales@vssystem.com](mailto:Sales@vssystem.com)

0800 018 2324