

DUO PERIMETER

use square washers (in lieu of clamp-bars) for acute angles

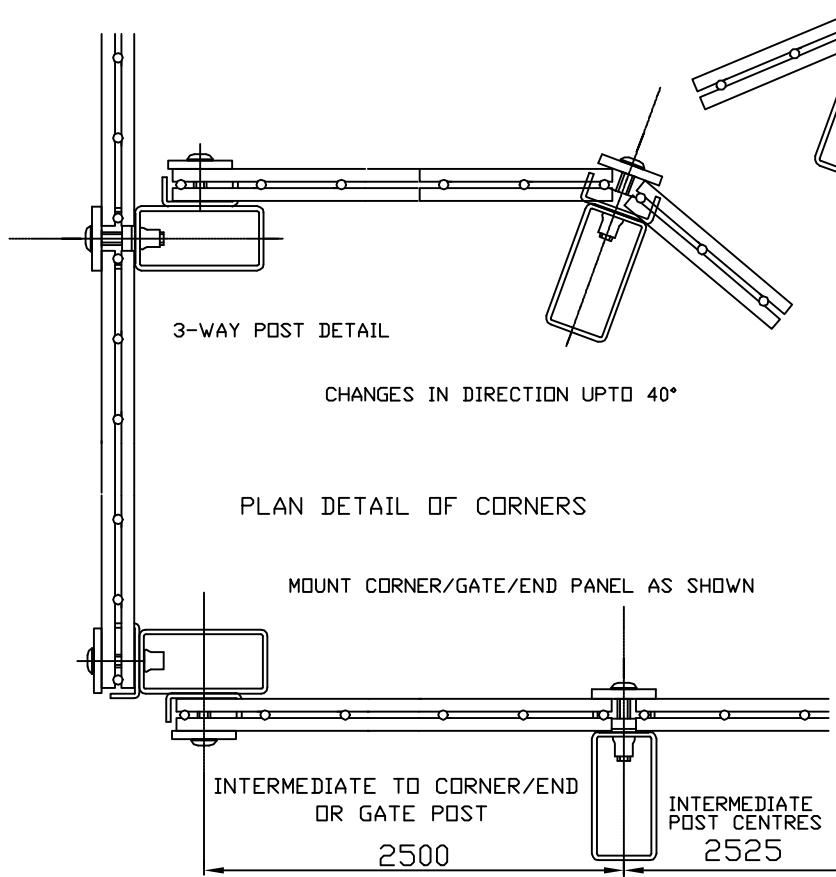

TOLERANCE ON POST CENTRES +/- 10mm

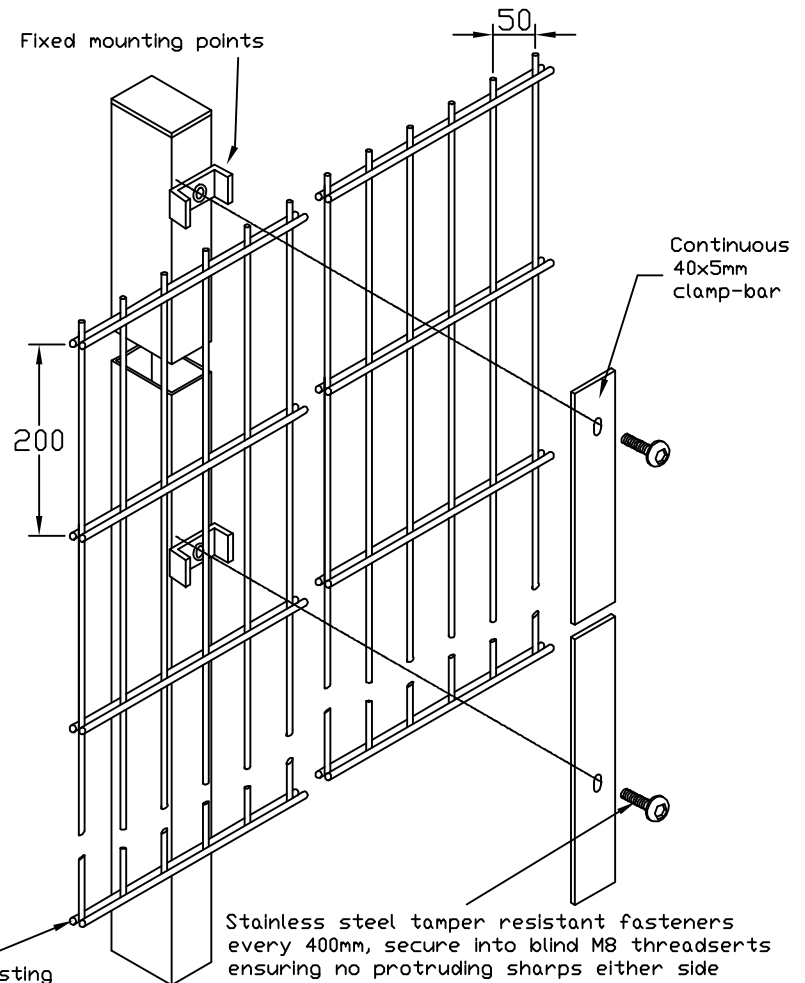
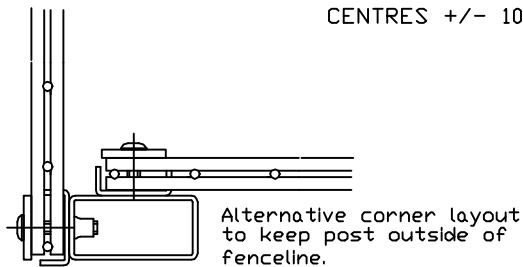

Each horizontal row consisting of two 8mm (Duo8) or 6mm (Duo6) wires, resistance welded at every intersection to 6mm verticals

Panels galvanised after welding to ensure maximum weld strength and corrosion resistance

Customer	www.zaun.co.uk	Drawing No.	
Project / Site	Duo Perimeter Fencing	Revision :	ORG
	Zaun Limited Steel Drive Wolverhampton WV10 9ED	Date	9/6/04
	Tel : 01902 796 699 Fax : 01902 796 698	Drawn By	PP